



# PHOTO TOOLS™

**User Guide**

**Version 3.0 for Macintosh® and Windows®**

© 1997 Extensis Corporation. This manual and the software described in it are copyrighted with all rights reserved. Under the copyright laws, neither this manual nor the software may be copied, in whole or part, without the written consent of Extensis Corporation, except in the normal use of the software or to make a backup copy of the software. This exception does not allow copies to be made for others.

Extensis, the Extensis logo, PhotoTools, PhotoAnimator, PhotoBars, PhotoGroove, Photo-CastShadow, PhotoBevel, PhotoEmboss, PhotoGlow, and PhotoButton are trademarks of Extensis Corporation. Adobe and Adobe Photoshop are registered trademarks of Adobe Systems Incorporated, which have been registered in the U.S. patent and trademark office and in many other countries. Apple and Macintosh are registered trademarks of Apple Computer, Inc. Microsoft and Microsoft Windows are registered trademarks of Microsoft Corporation. All other trademarks are the property of their respective owners.

Extensis warrants the disks on which the software is recorded to be free from defects in materials and faulty workmanship under normal use for a period of ninety (90) days from the original date of purchase. If a defect occurs during the 90-day period, you may return the disks to Extensis Corporation for a free replacement provided that you have previously registered your product with Extensis Corporation. This warranty is limited to replacement and shall not encompass any other damages, including but not limited to loss of profit, and special, incidental, or other similar claims. This software is provided on an "as is" basis. Except for the express warranty set forth above, Extensis Corporation makes no other warranties, either express or implied, regarding the enclosed software's quality, performance, merchantability, or fitness for a particular purpose.

**Extensis Europe**  
Zonnebaan 34  
3606 CB Maarssen  
The Netherlands

Telephone: #31 (0)30 247 50 50  
Fax: #31 (0)30 241 20 39  
E-mail: [extensis@euronet.nl](mailto:extensis@euronet.nl)

**Extensis Corporation**  
1800 SW First Avenue, Suite 500  
Portland, OR 97201

Telephone: (503) 274-2020  
Fax: (503) 274-0530  
Technical Support: (503) 274-7030  
E-mail: [support@extensis.com](mailto:support@extensis.com)  
<http://www.extensis.com>

# Contents

---

<b>Introducing PhotoTools</b> .....	<b>5</b>
System and Software Requirements .....	5
Installation .....	6
Technical Support .....	6
What is PhotoTools? .....	7
<b>PhotoTexture</b> .....	<b>10</b>
Getting Started with PhotoTexture .....	10
Creating Textures .....	14
The Toolbox .....	17
Effects and Filters .....	19
<b>The PhotoEffects Plug-ins</b> .....	<b>33</b>
Elements Common to All Effects .....	34
Getting Started with PhotoEffects .....	35
Common Elements Explained .....	38
Additional Information .....	46
<b>PhotoButton</b> .....	<b>49</b>
Getting Started with PhotoButton .....	54
Creating Custom Shapes .....	60
Creating Custom Bevels .....	62
Coloring Buttons .....	67
Adding Textures and Bump Maps .....	70
<b>PhotoGroove</b> .....	<b>71</b>
<b>PhotoCastShadow</b> .....	<b>77</b>
<b>PhotoBevel</b> .....	<b>84</b>
<b>PhotoEmboss</b> .....	<b>85</b>
<b>PhotoGlow</b> .....	<b>86</b>
<b>PhotoBars</b> .....	<b>87</b>
Getting Started with PhotoBars .....	88
<b>PhotoAnimator</b> .....	<b>103</b>
Getting Started with PhotoAnimator .....	104
Animation Functions and Settings .....	109
Effect Settings .....	110
Importing and Exporting .....	117
<b>Tutorials</b> .....	<b>120</b>
PhotoAnimator: Tutorials 1-5 .....	120
PhotoTexture/PhotoButton: Tutorials 6-7 .....	167
<b>Appendix A: Keyboard Shortcuts</b> .....	<b>174</b>
<b>Appendix B: Troubleshooting</b> .....	<b>176</b>
<b>Index</b> .....	<b>178</b>



# Introducing PhotoTools

---

Welcome to Extensis™ PhotoTools™! PhotoTools is a collection of creativity and productivity tools that enable you to work faster, easier, and more efficiently in Adobe® Photoshop®. This powerful collection includes: PhotoTexture, PhotoAnimator, PhotoGroove, PhotoButton, PhotoCastShadow, PhotoEmboss, PhotoBevel, PhotoGlow, and PhotoBars.



PhotoTools 3.0 responds primarily to user requests by enhancing the existing tools and adding three important new components: PhotoTexture, a full-featured texture creator; PhotoAnimator, an exciting animation editor; and PhotoGroove, an interactive custom bevel maker with user defined bevel edges. These new tools will have you producing stunning seamlessly tiled backgrounds and complex animations in no time. Enhancements to the existing plug-ins include the addition of user-defined shapes and unlimited bevel capability in PhotoButton, and multiple shadows from multiple light sources in PhotoCastShadow.

For quick and easy access, each component in the PhotoTools collection is available from the Extensis menu located in the Photoshop menubar, and from the PhotoTools menu in the Photoshop Filters menu.

## System and Software Requirements

---

To install and use Extensis PhotoTools, you will need the following:

### Macintosh:

- Power Macintosh® and PowerPC compatibles
- 3MB free hard drive space
- Mac OS® System 7.5 or later
- Adobe Photoshop 4.0 or later\*

### Windows:

- Pentium or faster PC
- 3MB free hard drive space
- Microsoft® Windows 95®, Windows 98®, or Windows NT® 4.0
- Adobe Photoshop 4.0 or later\*

\* PhotoAnimator is a stand-alone application and does not require Photoshop.

## Installation

---

You can find instructions for quick and easy installation on the CD-ROM that is included with your product or, if you downloaded an Extensis product installer from our web site, running the installer will place an informational Read Me on your hard drive.

## Technical Support

---

For questions regarding Extensis PhotoTools, please first refer to this manual, which describes the features and basic operations. We invite you to visit our PhotoTools page on the Extensis website ([www.extensis.com](http://www.extensis.com)) for frequently asked questions and troubleshooting tips.

### Tip

We can also be reached by:

**Fax:** (503) 274-0530

**E-mail:** [support@extensis.com](mailto:support@extensis.com)

**Internet:**

<http://www.extensis.com/support>

If you have a question which is not addressed in this manual or on the Extensis website, Technical Support is available by phone at (503) 274-7030 Monday through Friday 8:00 a.m. to 5:00 p.m. Pacific time. When calling for technical support, please be at your computer and have the following information available: your Extensis PhotoTools registration number, your computer configuration and your question or a description of the difficulty you're experiencing—what specifically occurs and when. Take note of any displayed error numbers or messages and any other information you think may be relevant.

## What is PhotoTools?

PhotoTools is a collection of creativity and productivity tools that enable you to work faster, easier, and more efficiently in Adobe® Photoshop®.

The PhotoTools collection includes:

- **PhotoTexture**—A richly featured texture editor that lets you design and create an unlimited variety of seamless textures from scratch, from a Photoshop selection, or from an imported JPEG (.jpg) image.

Using predefined texture effects and filters and a selection of Photoshop-like drawing tools

you can create seamless tiled backgrounds in a fraction of the time it would normally take.

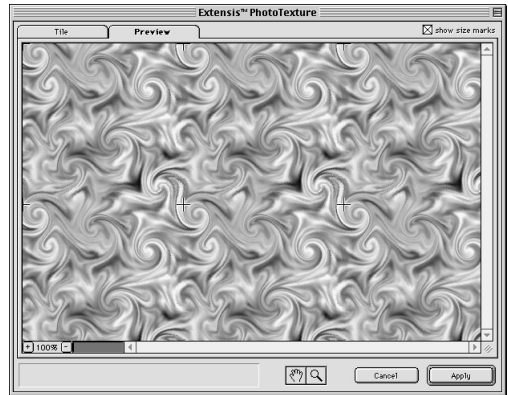

- **PhotoAnimator**—A stand-alone animation editor that helps you create stunning and exciting animations with almost no effort. Starting with raw animation elements saved either in

native Photoshop format (.psd), or as GIF images (.gif), you can use PhotoAnimator's intuitive tools to create the animation and add special effects. PhotoAnimator allows you to use layers and to apply effects to resizable cells and preview the results as you go, so you can see how your animation will look at every step. And since PhotoAnimator is a stand-alone application, you don't need to have Photoshop open to use it.

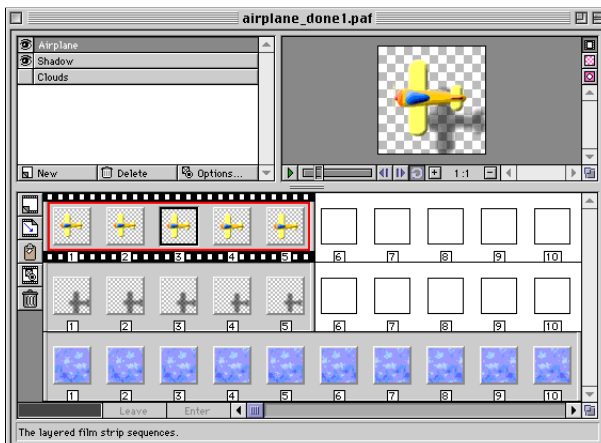

PhotoBevel 3.0	▶
PhotoButton 3.0	▶
PhotoCastShado...	▶
PhotoEmboss 3.0	▶
PhotoGlow 3.0	▶
PhotoGroove 3.0	▶

- **PhotoEffects**—Includes five plug-ins for you to use alone or in combination to quickly create dazzling effects on any image, and adds a sixth plug-in for creating consistent, stylized buttons such as those used on web pages and in multimedia projects.

With all the PhotoEffects plug-ins, see how your effects look in real-time and in relationship to the background and surrounding objects as you tweak, twist, blend, and shape using an effect plug-in’s unique tools to achieve just the right overall look. Change your mind at any time with multiple undos and redos—even reset your effect and start over from scratch. Save the settings for reuse and easy, one-click application.

The six PhotoEffects plug-ins include:

- **PhotoButton**—Quickly construct beautifully rendered, uniform matrices of buttons (such as those seen on web pages and in multimedia projects) using your own custom shape, or choose from 15 pre-defined but completely customizable shapes. Shape, color, bevel, and texturize your “anchor” button, then see your effects applied to all the other buttons. Use any combination of rotation angle, corner radius, inner height, bevel height, width, and curvature; change surface reflectivity, diffuse angle, and highlight color, ratio, and direction; and add textures—including bump maps—to create startlingly realistic 3-D buttons!

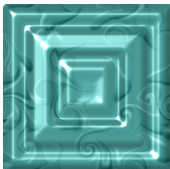
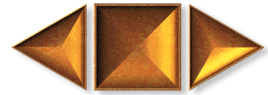

- **PhotoGroove**—Create complex custom beveled shapes effortlessly using PhotoGroove’s interactive, infinitely adjustable bevel shape editor.
- **PhotoBevel, PhotoEmboss, and PhotoGlow**—Create professional-quality bevels, embosses, and glows. Adjust image attributes using slider controls or numeric entry fields. Save settings for future use. And as with all Photo-Effects plug-ins, see how your changes look as you apply them—watch your effect’s color change as you move the mouse over the different colors in the color pop-up window!





- **PhotoCastShadow**—Create simple drop shadows with one click, or use any or all of 10 positioning and shaping tools to interactively skew shadows to your desired perspective. Easily adjust shadow blur for realistic 3-D images. Isolate the shadow on its own layer. Blend your shadow with other pixel values in the target layer. Add additional shadows for unique special effects. Creating realistic shadows has never been this easy!



PhotoTools also includes the popular floating toolbar plug-in:

- **PhotoBars**—Helps you manage menu options and tasks by making all menu and sub-menu commands available as clickable buttons which you access from convenient toolbars. Toolbars can be moved freely about in the display or embedded along any edge of the display, and you can rearrange, add or remove buttons and toolbars instantly. PhotoBars provides several pre-configured toolbars of commonly used commands; use these or create your own—even add buttons and toolbars for new filters and plug-ins as you go!

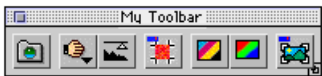

All PhotoTools plug-ins share a consistent interface, and were designed and tested to work smoothly with Photoshop versions 4.0 and later. We believe you'll find PhotoTools a natural extension of Photoshop, and an invaluable tool in your creative arsenal.

If you have questions, comments, suggestions, or we can help you in any way, please contact us at our Web site, <http://www.extensis.com>, or at the location listed on page 2. Contact information for technical support is given on page 6.

# PhotoTexture

## Tip

For a quick tutorial showing how to create a texture in PhotoTexture and add it to a button in PhotoButton, see *page 167*.

PhotoTexture is a full-featured texture editor that lets you easily create textures that tile seamlessly over any number of tiles. Create seamless custom textures from scratch using standard Photoshop-like drawing and coloring tools, or work from any Photoshop image or selection, or any imported JPEG image (.jpg). Special filters and effects included with PhotoTexture give you unlimited options for creating exciting seamless textures in minutes. Textures can be applied to an image and saved as usual from Photoshop—in any format that Photoshop supports—or saved directly from PhotoTexture as a JPEG file.

## The PhotoTexture Dialog box

- A** Tile Tab: Provides access to all texture editing options.
- B** Preview: Provides access to a larger preview of the tiled texture. See *page 27*.
- C** Toolbox: Standard Photoshop-like tools for drawing and coloring texture elements. See *page 17*.
- D** Drawing Area: Displays the texture as you create and modify it. Tiles are always displayed in a 3x3 matrix in this window.
- E** Base Tile: Represents the pattern area that is saved when the texture is applied or saved.
- F** Size Marks Toggle: Toggle tile size marks on or off. Or press the **M** key.
- G** Texture file options: Allows you to create and save texture files. Displays tile size and resolution. See *page 13*.
- H** Texture Effects: Provides special effects and filters for creating custom textures. See *page 20*.
- I** Help Box: Displays a description of each tool or option as the mouse passes over it.
- J** Cancel: Closes the dialog box without making changes to the image. Also Cancel by pressing **Command+“.”** (period) [**Alt+F4**].
- K** Apply: Adds your selected effects to the image and closes the dialog box. You can also Apply the effect by pressing **Return** or **Enter**.

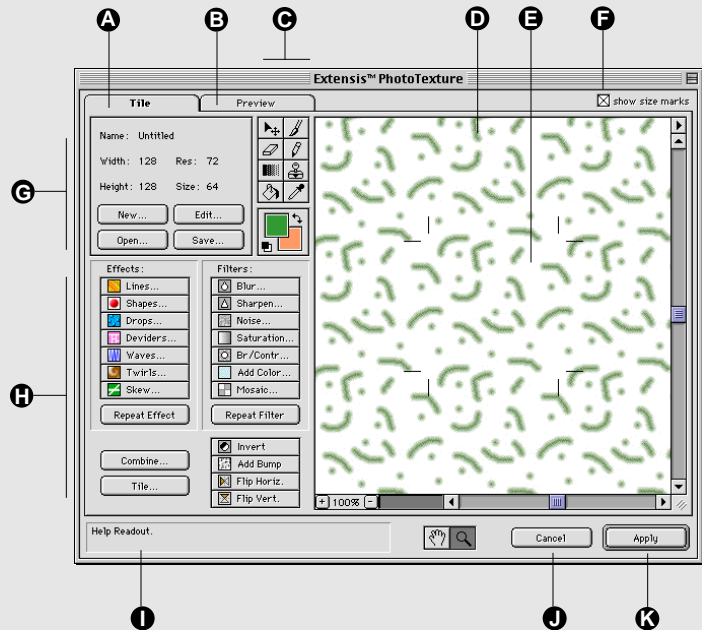

## Getting Started with PhotoTexture

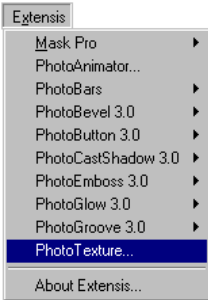

### Tip

PhotoTexture only works with images in the RGB color space.

### Tip

To toggle the Size Marks on or off, press the **M** key.

You can create textures in PhotoTexture in one of three ways:

- Create a texture from scratch using the painting and coloring tools and the special Effects and Filters in PhotoTexture.
- Specify a Photoshop image or selection area to be used as the base for the texture.
- Import an existing JPEG (.jpg) image directly into PhotoTexture to be used as the base for a texture.

You create textures by designing a “base tile” that can be replicated numerous times to create an overall texture effect. Typically you would want your pattern to be as seamless as possible so that no matter how large an area it is applied to, you will not see where the initial pattern begins and ends. With PhotoTexture you can create exciting seamless textures with ease.

As you create your base tile, PhotoTexture helps you visualize your texture by displaying a 3x3 tile matrix and replicating your base tile design over the nine tiles. The center tile in the Drawing Area represents your base tile; it is delineated by Size Marks in each of the four corners so you can continue to see the base tile pattern as the texture develops.



Base tile saved

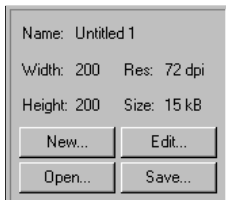

Base tile size



Base tile replicated over 3x3 tile matrix

Use PhotoTexture's customizable Effects and Filters to create interesting patterns with just a few clicks—or customize Effects or Filters and save your settings for future use. You can reapply an Effect or Filter as many times as you like to achieve just the right effect, and even combine your design with previously saved textures. Add additional touches to your textures with common painting tools like Paintbrush, Paint bucket, Pencil, Rubber Stamp, and more.

When you've created a tile design that you like, you can save it in one of two ways:

- Apply the texture to an image or selection area in Photoshop (or to a blank Photoshop document, if you are creating a texture from scratch).
- Save the texture directly from PhotoTexture as a JPEG (.jpg) format file.

If file size is not a problem, you can replicate your base tile right in PhotoTexture to create a larger tile (up to 512 x 512 pixels) before saving.

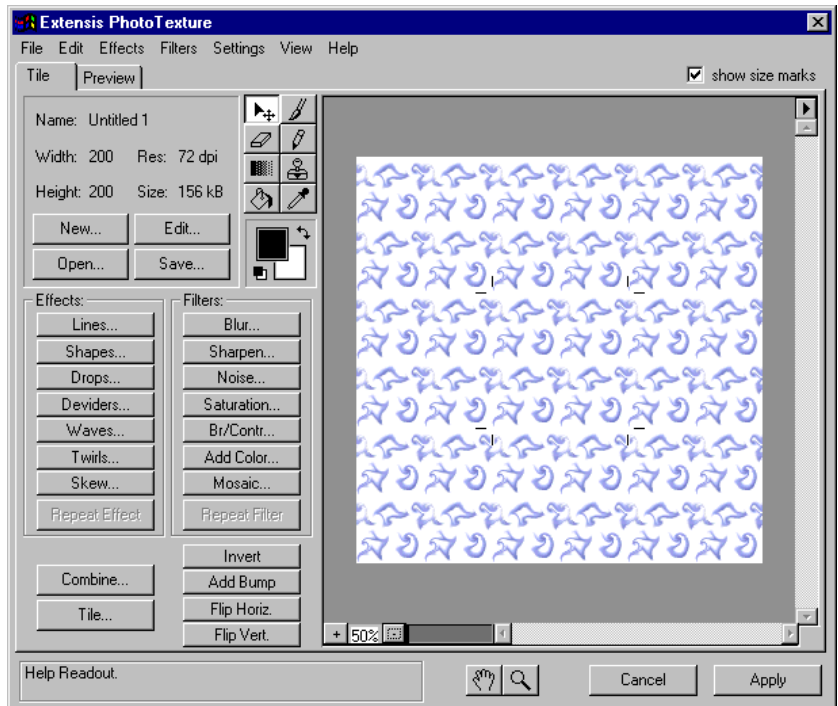

## Texture File Options

Texture File Options allow you to create, edit, and save your texture.

- A** Texture Name: Displays texture name, if a texture name exists.
- B** Width and Height: Displays the size of the base tile.
- C** New: Opens the New texture dialog allowing you to create a new texture. Discards the current texture, if any.
- D** Open/Save: Allows you to locate and open a JPEG file to be used as a base tile for the texture, or to save a texture as a JPEG format file. See [page 16](#).
- E** Tile Size and Resolution: Displays the file size and resolution of the base tile. Size is calculated based on the Width, Height, and Resolution of the base tile. Resolution is informational and cannot be changed in PhotoTexture.
- F** Edit: Opens the Edit dialog allowing you to modify the Name, Width, or Height of the current texture.

### New texture/Edit texture dialogs:

- G** Texture Name field: Enter a name for the texture. A texture name is not necessary if the texture will be applied to a Photoshop selection.
- H** Width and Height fields: Displays the size of the current base tile. Enter the size of the base tile that you wish to create. See [page 11](#).
- I** Measurement pop-up menu: Determines which unit of measure Width and Height values will be displayed in. Options are Pixels, Inches, Centimeters.
- J** Contents: Determines what will form the basis of the texture. Options are: Blank, Selection from Photoshop, or Continue with last Texture.
- K** OK: Accepts the settings and creates (or changes) the base tile based on the selections in the dialog.
- L** Show this dialog next time: When checked, opens the New dialog when PhotoTexture is opened. When unchecked, automatically opens PhotoTexture in "Selection from Photoshop" mode.

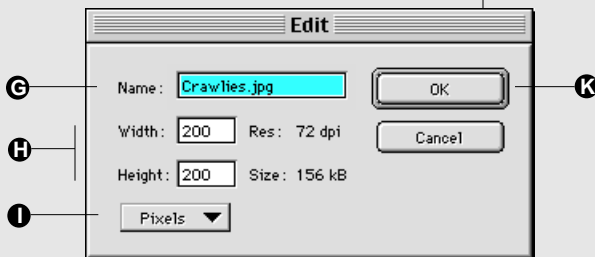
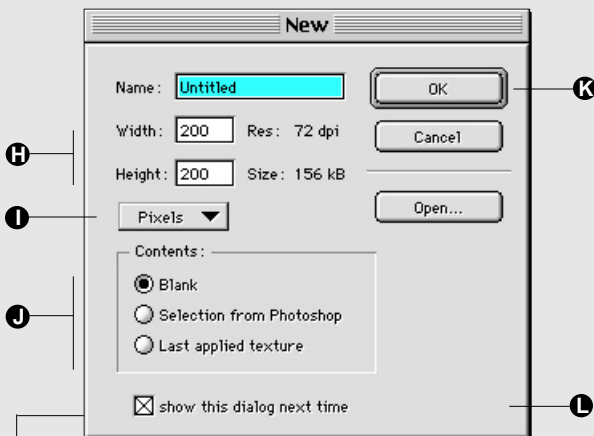

## Creating Textures from Scratch

---

When you create a texture from scratch, you first create a blank document in Photoshop at the size that you want, choose RGB mode, then open PhotoTexture. PhotoTexture automatically creates a base tile the same size as the active document.

To create your tile pattern, simply start drawing with the PhotoTexture painting tools, or create a base pattern using any combination of Effects and Filters. As you draw or add effects, the pattern is replicated over all the tiles. You can turn the tile size marks off and on to get a better idea of how the pattern will look, and you can reposition the pattern on the tile by moving it around with the Move tool. To see the pattern replicated over a larger area, select the Preview tab.

### To create a texture from scratch:

1. **Open Photoshop.**
2. **Open a new document (Command-N [Ctrl+N]) and specify the size parameters that you want for your base tile. Verify that RGB is the active mode.**

When you “Apply” your texture from PhotoTexture it is automatically applied to the active document.

*Note: When no selection area is specified, the entire image area is assumed. See page x for information on using a selection area as the base for the texture.*

3. **Open PhotoTexture by choosing “PhotoTexture” from the Extensis menu.**

The New texture dialog will be displayed.

4. **Click the “Blank” radio button.**

This indicates that you want to create a texture from scratch, using a blank tile. PhotoTexture will create a base tile the same the height and width as the Photoshop document you created in step 1.

5. **You can now create your texture using PhotoTexture Effects, Filters, and tools (see pages 19-26). When you have created a texture that you like, click “Apply” to apply it to your Photoshop document (see page 19).**

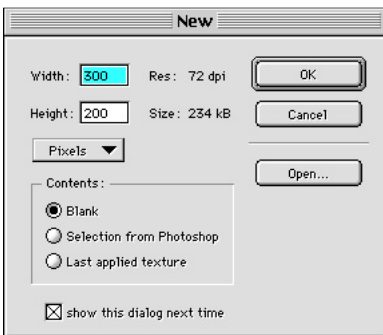

## Creating Textures from a Photoshop Selection

When you select a Photoshop image or an area of the image using Photoshop selection tools (such as the marquee tools), the selection area is replaced by the newly created texture when you click the Apply button in PhotoTexture. Creating a texture from an existing image may not allow you to create the kind of seamless textures that are possible when creating textures from scratch. For more information on Photoshop selections, refer to your Photoshop User Guide.



### To create a texture from a Photoshop image or selection:

- 1. In Photoshop, open the image that you want to use for the base tile. Select the area that you want to use.**

If you do not specify a selection, PhotoTexture assumes that you want to use the entire image.

- 2. Open PhotoTexture by choosing Extensis > PhotoTexture.**

The New texture dialog will be displayed.

- 3. Click the “Selection from Photoshop” radio button.**

PhotoTexture will use your selection as the base tile, and replicate the image over the nine tiles in the 3x3 matrix in the Drawing Area.

- 4. Modify the design using the PhotoTexture painting tools, or combine Effects, Filters, and tools to create the texture you want.**

- 5. When you are finished creating your texture, click “Apply” to apply the texture to your image.**

Your new texture will replace the image or selection area.

- 6. Save the Photoshop file in the normal way.**

## Continuing with the Last Applied Texture

---

You can open PhotoTexture to the texture and settings that were last applied. This is handy if you want to continue with a pattern that you had started earlier, or if you want to create a larger Photoshop file to apply the image to.

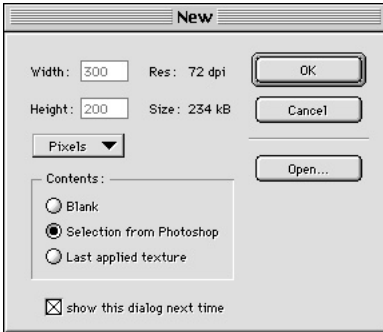

**To continue with the last applied texture:**

- 1. In Photoshop, either create a new file for the texture the same size as the base tile you want to create.**

If you do not specify a selection, PhotoTexture assumes that you want to use the entire image.

- 2. Open PhotoTexture by choosing Extensis > PhotoTexture.**

The New texture dialog will be displayed.

- 3. Click the “Continue with last Texture” radio button.**

PhotoTexture will open with the tile size, pattern, and settings that were last applied (or saved).

- 4. Modify the design using the PhotoTexture painting tools, or combine Effects, Filters, and tools to create the texture you want.**

## Creating Textures from an Existing File

---

You can create a new texture from an existing texture by opening it directly in PhotoTexture. This feature allows you to create textures from scratch, save them from PhotoTexture as JPEG (.jpg) files, then open them later for more editing. You can create textures based on any JPEG image, but doing so may not allow you to create the kind of seamless textures that are possible when creating textures from scratch.

**To create a texture from an existing JPEG (.jpg) file:**

- 1. From the New dialog (or from the Texture File Options area of the Tile tab), click the “Open” button .**
- 2. Locate the JPEG file you wish to use as the base tile, then click “Open.”**

A base tile will be created using the imported image.

- 3. When you are finished modifying your texture, click “Save” in the Texture File Options area of the Tile tab to save it back out as a JPEG image.**

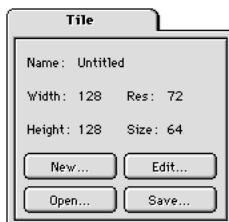



## The Toolbox

PhotoTexture's Photoshop-like painting and coloring tools let you create patterns freehand. To select a tool, click its icon on the Toolbox, or press the indicated key. For additional information on these tools, refer to your Photoshop User Guide.

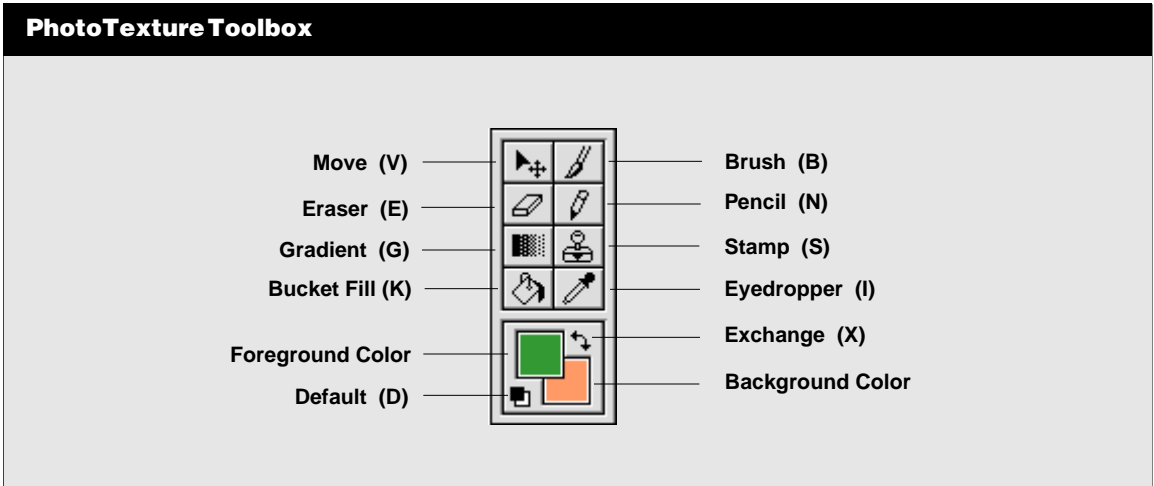

Key	Tool	Description
V	Move	Lets you reposition the texture on the tile.
E	Eraser	Changes pixels in the image to the background color.
G	Gradient	Creates a gradual blend between the foreground and background colors. Shades from the starting point to the ending point in a straight line. <i>Note: Provides Horizontal and Vertical gradients only, to ensure seamless textures.</i>
K	Bucket (Fill)	Paint bucket fills adjacent pixels that are similar in color value to the pixels where you click.
B	Brush	Paintbrush creates soft strokes of color.
N	Pencil	Creates freehand lines.
S	Stamp	Rubber stamp takes a sample of the image, which you can apply in other areas of the image.
I	Eyedropper	Extracts a color from the image for the Foreground or Background color.
	Foreground Color	Click to open the system color picker to choose a foreground color.
	Background Color	Click to open the system color picker to choose a background color.
X	Exchange	Color switcher exchanges the current foreground and background colors.
D	Default	Sets the foreground and background colors to their default values (foreground black, background white).



### Tip

You can access the Rubber Stamp, Paint Bucket, and Brush tool Settings by **double-clicking** the tool on the Toolbox palette.

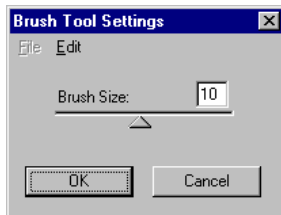
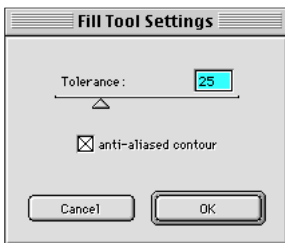
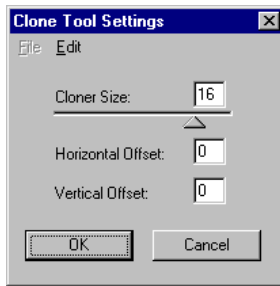

## Stamp, Fill, and Brush Settings

Using commands on the Settings menu you can specify settings for the following tools: Rubber Stamp, Fill (Paint Bucket), and Brush.

### Stamp

The Stamp tool works like the rubber stamp tool in Photoshop: using it you can take a sample of the texture which you can apply to other areas of the texture. Cross hairs mark the original sampling point. This tool is handy for smudging the edges of an existing image to give it a more seamless look.

**To use the Rubber Stamp Tool:** Position the stamp pointer on the part of the texture that you want to sample then **Option-click** [Alt-click]. This sample point is the location from which the image is duplicated as you paint.

You can change the size of the sample area, and the Horizontal and Vertical Offset of the sample as you paint with the Rubber Stamp, by selecting "Stamp..." from the Settings menu.

### Fill (Paint Bucket)

The Fill tool (Paint Bucket) fills an area of adjacent pixels with the current Foreground color.

You can change the tolerance of the fill by selecting "Fill..." from the Settings menu. Tolerance defines how similar in color a pixel must be to be filled. A low tolerance fills pixels within a range of color values very similar to the pixel you click. A high tolerance fills pixels within a broader range.

You can smooth the edges of the filled selection by choosing "Anti-aliased Contour" from the Fill Tool Settings.

### Brush

You can change the size of the Brush by selecting "Brush..." from the Settings menu. Size is indicated in pixels.

## Effects and Filters

You can create interesting and eye-catching seamless effects with little or no effort using PhotoTexture preconfigured and customizable Effects and Filters. Effects and Filters can be repeated numerous times, and they can be combined with each other; with the designs that you draw using the PhotoTexture tools; and with other textures, creating truly unlimited possibilities. You can select from different preconfigured Effect settings, or create and save your own settings.

### Tip

To apply the effect repeatedly without closing the Effect or Filter dialog, press **Command [Ctrl]**. The “Apply” button will become “Apply Again.” You can click Apply Again until you achieve just the effect you want.

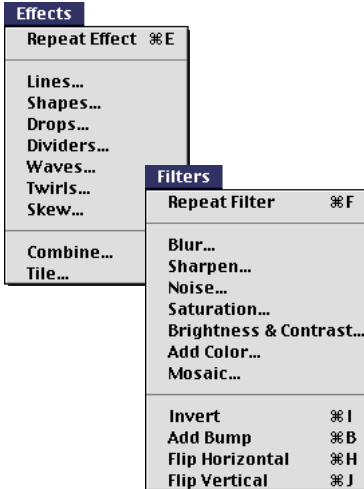

### Tip

If you do not like the effect after you close the dialog, select Undo from the edit menu (or press **Command-Z [Ctrl+Z]**). Select “Clear” from the Edit menu to clear the screen and start over.

### To apply Effects and Filters:

1. Choose an Effect or Filter from the list (*page 20*) and click its button to select it.

— or —

1. Choose an Effect or Filter from the Effects or Filters menu in the PhotoTexture menu bar.

This opens the dialog for the Effect or Filter, allowing you to change the settings.

2. Click “Apply” to apply the setting to the texture in the Edit Texture window.

This allows you to see the results of the applied Effect or Filter without closing the dialog box. If necessary, reposition the Effect or Filter dialog box so that you can see the texture and the dialog box at the same time.

**3.If you do not like the effect, experiment with the Effect or Filter settings by changing the values, and click Apply to see the changes. Continue to experiment with the Effect or Filter settings until you have achieved just the right effect, then click “OK.”**

This applies the effect to the texture and closes the dialog.

If you do not like the effect at all, click “Cancel” to close the dialog without making any changes to the texture.

4. You can apply additional Effects and/or Filters by following steps 1 through 3 until your texture is just the way you want it. Repeat the last effect that was applied by clicking the “Repeat Effect” or “Repeat Filter” button (or by selecting these commands from the Effects or Filters menu).

## PhotoTexture Effects and Filters

**A** Effects: Includes seven completely customizable Effects: Lines, Shapes, Drops, Dividers, Waves, Twirls, and Skew.

Click an Effect button to open a dialog allowing you to modify the Effect parameters. Click the Apply button in the Effect dialog to see how different values will affect the image. You can even save Effect Settings for future use. See page 29.

**B** Filters: Includes seven completely customizable Filters: Blur, Sharpen, Noise, Saturation, Brightness and Contrast, Add Color, and Mosaic.

Click a Filter on the list to open a dialog allowing you to modify the Filter parameters. Click the Apply button in the Filter dialog to see how different values will affect the image. See page 19.

**C** Effect Button

**D** Repeat Effect: Click to apply the last applied Effect again. You can apply an effect multiple times.

**E** Combine: Allows you to combine existing textures together. See page 30.

**F** Tile: Allows you to change the number of pattern repetitions on the base tile.

**G** Filter Button

**H** Repeat Filter: Click to apply the last applied filter again. You can apply a filter multiple times.

**I** Additional Filters: Invert, Add Bump, Flip Horizontal and Flip Vertical. These filters do not have additional settings and are applied immediately when the button is clicked.

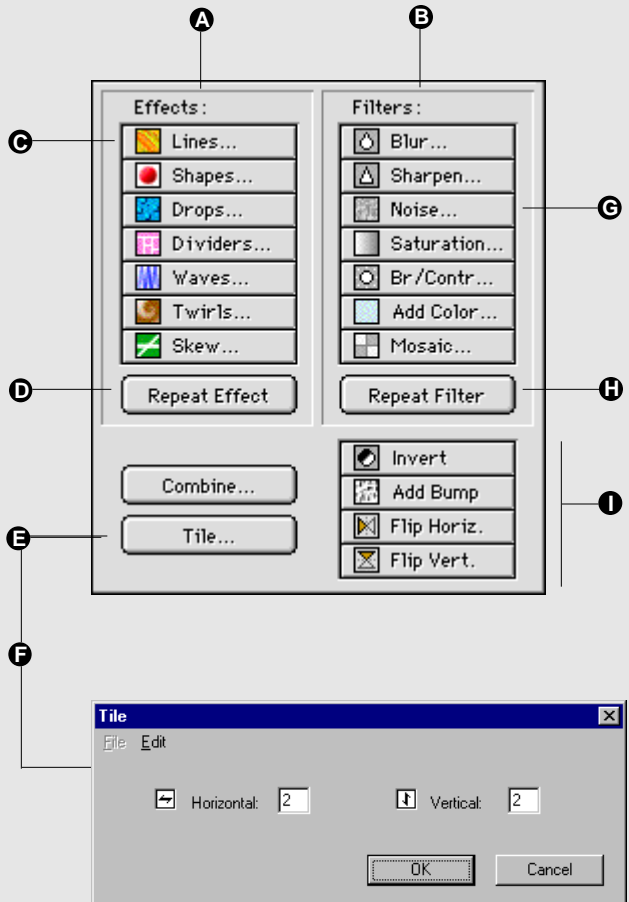

## Working with Effects

Selecting an Effect from the Effects List opens the dialog box for the Effect, allowing you to set effect parameters and apply the effect. You can also create, modify, select, and save Effect Settings for the selected effect.

- A** Preset Effect pop-up: Select a saved effect from the list. Effect settings that you save for a particular Effect are available from the Preset list for that Effect.
- B** Save: Allows you to save and name the current Effect settings for later use. Effect settings that you save for a particular Effect are available from the Presets pop-up menu (**A**).
- C** Delete: Deletes the selected Preset from the Preset list.
- D** Effect Settings: Allows you to change how the Effect will look. The settings options are different for each Effect.
- E** Apply: Click to apply the displayed Effect settings to the image in the Edit Texture window without closing the dialog. Press **Command [Ctrl]** to get "Apply Again," allowing you to repeat the effect numerous times without closing the dialog.
- F** Cancel: Close the Effect dialog without applying changes.
- G** OK: Close the dialog and applies the Effect settings to the image in the Edit Texture window.

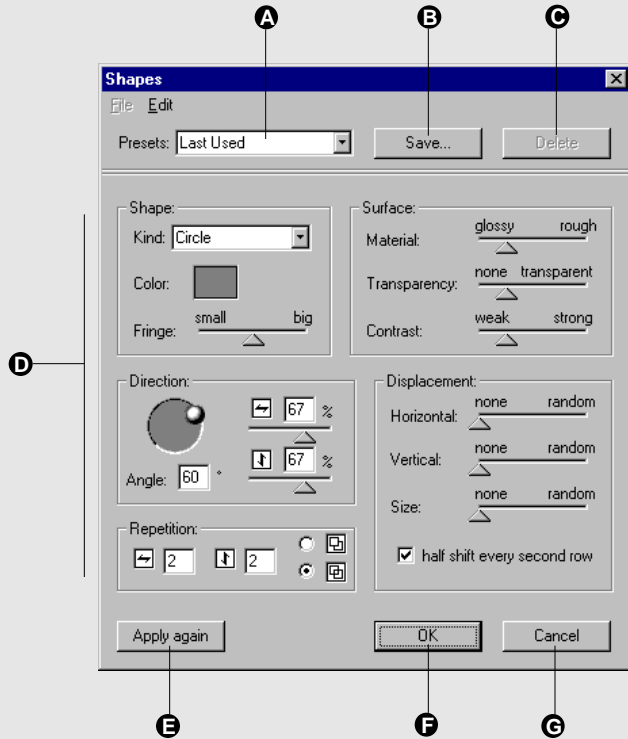

## Working with Filters

Selecting a Filter from the list opens the Filter dialog box, allowing you to set parameters and apply the filter.

- A** Filter Settings: Allows you to change the effect of the selected Filter.
- B** Apply: Click to apply the displayed Effect settings to the image in the Edit Texture window without closing the dialog. Press **Command [Ctrl]** to get "Apply Again," allowing you to repeat the effect numerous times without closing the dialog.
- C** Cancel: Closes the Filter dialog without applying changes.
- D** OK: Closes the dialog and applies the Filter settings to the image in the Edit Texture window.

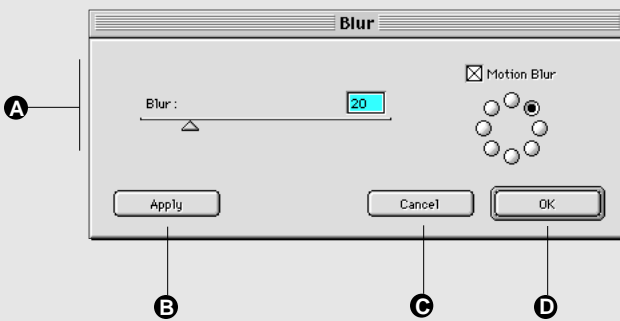

## Effects—Lines, Shapes

**Lines:** Creates a base pattern of multiple single color or multi-colored lines according to the Lines settings.

- A** Precision: High or Low. Determines how skewed (Low) or organized (High) the lines will be.
- B** Appearance: Wax (anti-aliased) or Ink (not anti-aliased).
- C** Color: Random, Average Color. Choosing a "Random" setting creates lines of different colors. Selecting "Average Color" creates lines of a single color. Click the Color box to open the system color palette to choose a color for the lines.
- D** Angle: Use the directional model control knob or enter a value for the angle of the lines.

**Shapes:** Creates a base pattern of shapes according to the the Shapes settings.

- E** Shape: Kind: Choose from Square, Circle, or Ring. Color: Click the Color box to choose a color for the shapes. Bevel: Drag the slider to set bevel size.
- F** Direction: Angle: Determines the angle or skew of the shape. Drag the directional control or enter a value. Horizontal and Vertical Size: Drag the sliders to set the size. 100% represents maximum size.
- G** Repetition: Sets the matrix of how many shapes will be placed in the base tile. 1x1 places one shape; 2x2 places four shapes, etc. Radio buttons determine whether shape will overlap or blend with the existing texture.
- H** Surface: Determines the surface properties of the shapes. Material: Sets the texture to be smooth (glossy) or bumpy (rough). Transparency: Determines how transparent the shapes will be. Contrast: Determines how much contrast is applied to the shapes.
- I** Displacement: Determines the offset of shapes from each other vertically and horizontally. No displacement (none) arranges the shapes in orderly rows. Full displacement (random) creates disorderly, random patterns from the shapes. Half-shift every second row: Displaces shapes by row.

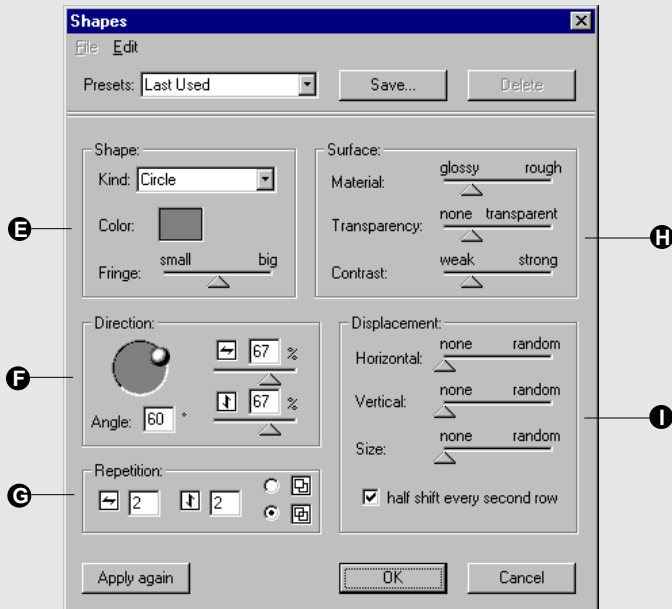
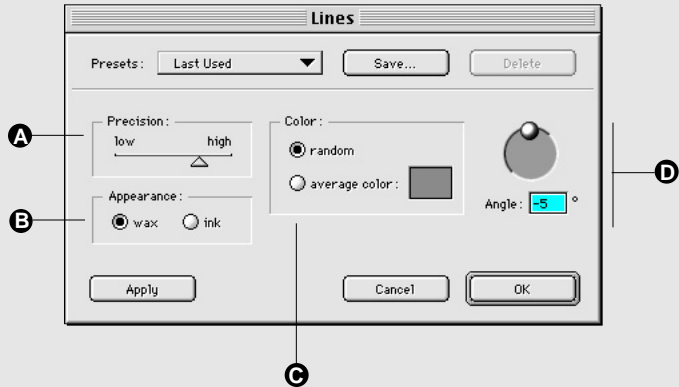

## Effects—Drops, Dividers

**Drops:** Creates a water-droplet pattern using the background color or current texture.

- A** Drops: Determines the amount (few to many) and size (small to big) of the droplets, and whether they are uniformly sized (same) or randomly sized (different).
- B** Reflection: Determines how the light source affects the shapes, giving them a washed out (dim) or emphasized (glossy) appearance. Emphasize light: When checked, gives the droplets a stronger 3-D appearance.
- C** Covered area: Determines how the droplets affect the background pattern. "Normal" allows the background to show through the droplet just as it is. "Blurred" blurs the pattern where it shows through the droplet. Most noticeable on a multi-pattern background.

**Dividers:** Creates a base pattern by dividing the screen into multiple sized boxes using one or more colors.

- D** Lines: Determines how many lines are created (few to many) and orientation mix of the lines (mostly horizontal, mostly vertical, or equal).
- E** Colors: Random Colors applies lines in multiple colors. From Color Picker creates lines using the current Foreground and Background colors. Transparent allows the background to show through the spaces between the lines.
- F** Size: Determines line thickness and the variation of the lines. Line Width: Determines minimum line width, in pixels. Width Variation: Determines how much the line width will vary from 0% (all lines will be of equal size) to 100% (maximum variation). Minimal Gap Between Lines: Determines the minimum amount of space between lines, in pixels.
- G** Drawing: Use Anti-Aliased Lines: When checked, blurs lines using antialiasing.

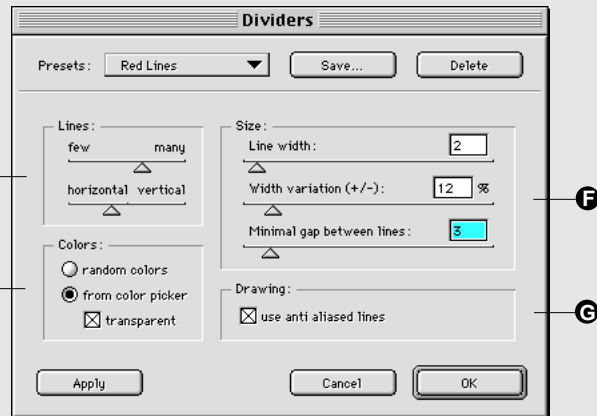
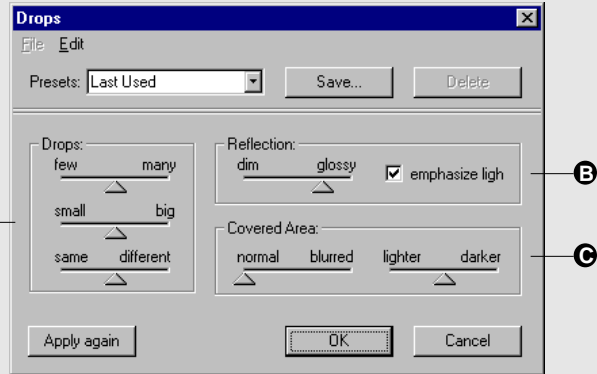

## Effects—Waves, Twirls, Skew

**Waves:** Creates a pattern by applying hard or soft waves to the elements in the current texture, either horizontally, vertically, or both. Has no effect if the texture is blank or a solid color.

- A** Horizontal: Sets wave parameters to be applied horizontally. Waveform: Choose None, Sine, Sawtooth, or Square or Random. Height: Determines the size of the wave, as a percentage of the total pattern. Count: Determines how many waves will be applied in the base tile area.
- B** Vertical: Same as horizontal, but the wave settings affect the pattern vertically.

**Twirls:** Creates a pattern by swirling the elements in the current texture. Has no effect if the texture is blank or a solid color.

- C** Quantity: Determines how much of the pattern is swirled, as a percentage of the total. 1% applies minimum swirliness; 100% applies maximum swirliness.
- D** Size: Determines the size of the swirls as a percentage of total size of the pattern.
- E** Intensity: Determines the intensity of the swirl. An intensity of 0% applies minimum swirliness, 100% applies maximum swirliness.

**Skew:** Creates a pattern by skewing the elements in the current texture. Has no effect if the texture is blank or a solid color.

- F** Skew direction: Sets the direction of the skew: from Left, from Right, from Bottom, from Top.

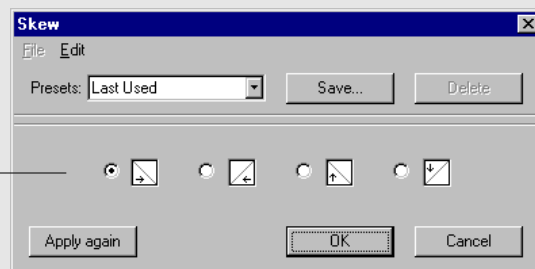
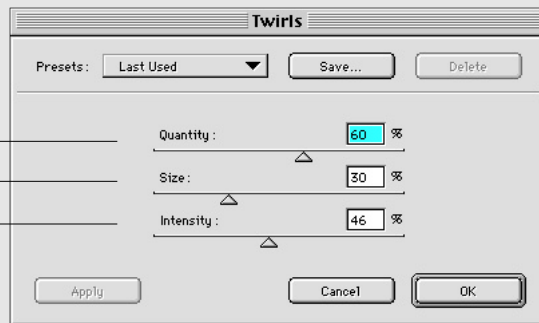
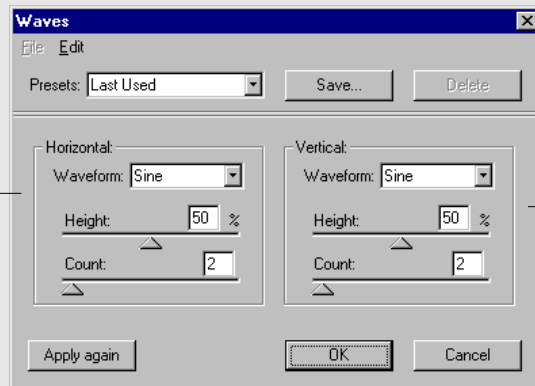



## Filters—Blur, Sharpen, Noise, Saturation

**Blur:** Softens the image. Smooths transitions by averaging the pixels next to the hard edges of defined lines and shaded areas.

- A** Blur amount: Use the slider or enter a value between 0 (no blur) and 100 (maximum blur).
- B** Motion Blur: Click to create a blur that simulates motion.
- C** Direction: Click a button to indicate the originating direction of a motion blur.

**Sharpen:** Focuses texture by increasing the contrast between pixels.

- D** Sharpen amount: Use the slider or enter a value between 1 (minimum sharpen) and 5 (maximum sharpen).

**Noise:** Adds “noise,” or randomly distributed colors to the texture.

- E** Noise amount: Use the slider or enter a value between 0% (no noise) and 100% (maximum noise).
- F** Color: Select noise pixels in: Black & White; Colored; and Really Colorful.

**Saturation:** Increase or decrease the color saturation.

- G** Saturation amount: Use the slider or enter a value from -50% to +50%.

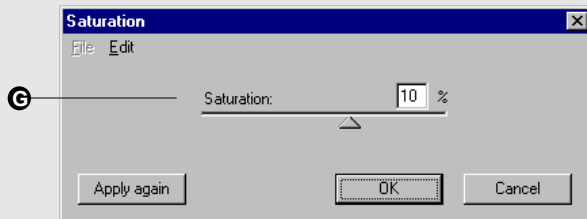
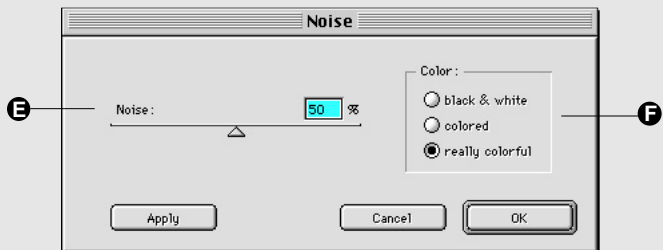
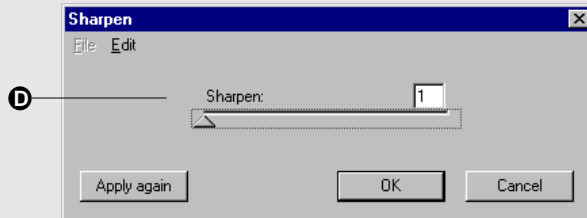
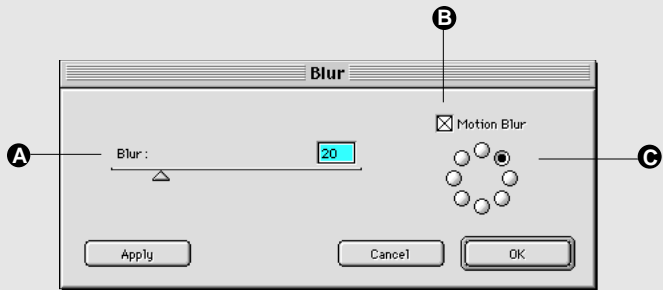

## Filters—Brightness/Contrast, Add Color, Mosaic

**Brightness and Contrast:** Adjusts the tonal range of the image. Affects all pixel values in the texture: highlights, shadows and mid-tones.

**A Brightness:** Use the slider or enter a value between -100% (minimum brightness) and 100% (maximum brightness).

**B Contrast:** Use the slider or enter a value between -100% (minimum contrast) and 100% (maximum contrast).

**Add Color:** Adds a color to the image, with adjustable opacity.

**D Color:** Click to open the system color palette allowing you to select a background color.

**E Opacity:** Use the slider to adjust the opacity between 0% (minimum opacity) and 100% (maximum opacity).

**Mosaic:** Applies a pixelated effect to the texture.

**F Horizontal:** Select a number from the pop-up menu between "None" (no horizontal mosaic effect) and 8 (maximum mosaic effect horizontally). The mosaic "squares" are measured in pixels.

**G Vertical:** Same as Horizontal, but affects the texture vertically.

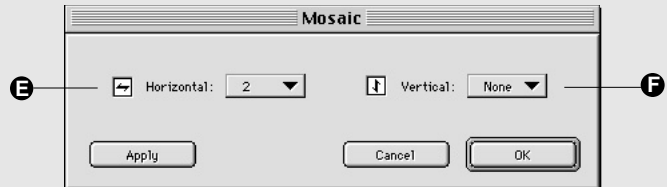
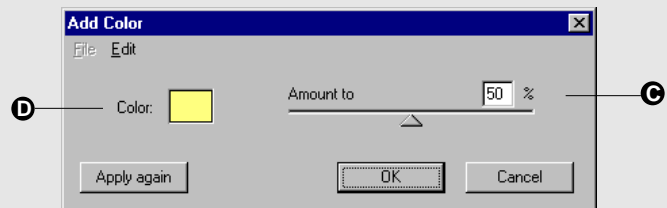

### Additional Filters

PhotoTexture provides four filters that do not have dialog boxes and are applied directly when you click the button.

**Invert:** Inverts texture color: The color of each pixel is converted to its inverse value.

**Add Bump:** Gives the texture pattern a raised appearance by beveling areas of similar color.

**Flip Horizontal/Flip Vertical:** Flips the texture horizontally or vertically: The texture is rotated 180° from its current position.

## Texture Preview

---

### Tip

To toggle between the Preview tab and the Tile tab, press the “P” key.

You can see how your pattern will look when applied to a larger area by examining it in the Preview window. You add or remove the Size Marks from the Preview to get a better idea of how the pattern will look.

### To view an enlarged Preview of the texture:

- **Click the Preview tab**

To return to the Edit Texture window, click the “Tile” tab.

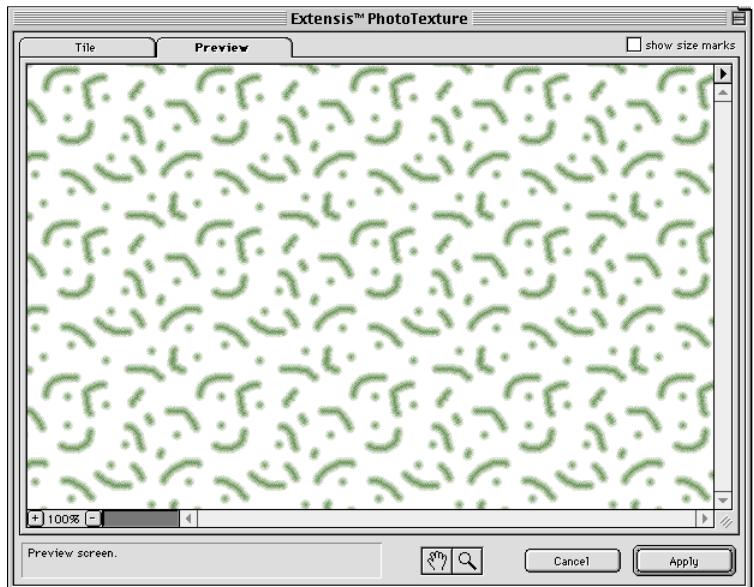

## Zooming and Panning

---

The Zoom and Pan (Hand) tools perform the same functions as the Photoshop Zoom and Hand tools.



### Tip

To return to 100% magnification and center the base tile in the window, press **Command-0** [**Ctrl+0**] or select “Actual Pixels” from the View menu.

### Tip

**Macintosh Users:** To momentarily switch to the Hand tool from any other tool, press the **Spacebar**.

To momentarily access the Zoom tool when the Hand tool is active, press **Command** (Zoom In) or **Option** (Zoom Out).

*Note: These commands work together: With any tool selected, press Spacebar to activate the Hand tool, then also press Command or Option to access a Zoom tool.*

### To Zoom In:

- **Select the Zoom tool (magnifying glass), then click the area of the image you want to magnify.**

Each click magnifies the image to the next percentage, and the magnified display is centered around the point you click.

— *or* —

- **Press Command-Shift-“+” or Command-Keypad “+” [Ctrl+Keypad “+”].**

— *or* —

- **Choose View > Zoom In from the menubar.**

### To Zoom Out:

- **Select the Zoom tool (magnifying glass). While pressing Option [Alt], click the area of the image you want to reduce.**

Each click reduces the image to the next percentage.

— *or* —

- **Press Command-Shift-“-” or Command-Keypad “-” [Ctrl+Keypad “-”].**

— *or* —

- **Choose View > Zoom Out from the menubar.**

### To Pan (Scroll) in the Drawing Area:



**Select the Hand tool and drag the image until you locate the area you wish to view.**

— *or* —

- **With any other tool selected (Macintosh only), press Spacebar while you drag the image in the window.**

## Applying and Saving Textures

---

You can save a texture in one of two ways: by applying it to an image in Photoshop, or by saving it from PhotoTexture as a JPEG format file.

When you apply a texture to an image in Photoshop, the new tile replaces the image or selection, and the pattern size that is applied is limited to the size of the selection area. Applying your texture to a Photoshop document and then saving allows you to save the texture in any format supported by Photoshop.

When you save a texture from PhotoTexture as a JPEG file, tile size can be changed from within PhotoTexture. That is, you don't have to know before opening PhotoTexture how large the tile will be since you can change it at any time. You can only save from PhotoTexture as a JPEG format file.

### To apply a texture to a Photoshop document or selection:

1. When you are ready to save your texture, click the “Apply” button in the Drawing Area on the Tile tab.

This replaces the Photoshop image (if any) or selection area with the texture you created. You can continue working with the pattern in Photoshop, or save the file using any format supported by Photoshop.



### To save a texture from PhotoTexture:

1. When you are ready to save your texture, click the “Save” button in the Texture File Options area of the Tile tab.

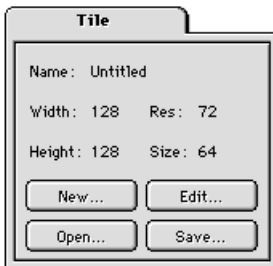

## Combining a Texture with an Existing Image

You can use the Combine feature to merge existing textures and images with your base tile pattern to create some really spectacular effects. Any JPEG (.jpg) file can be used, but the file and the texture base tile must be the same size.

Combine options are:

**Blend this texture with <filename>:** Blends the pattern in the file you specify with the pattern on the base tile. Select an opacity for the blend between 0 and 100%. Opacity values closer to 0 allow more of the base tile texture to show through; values closer to 100% allow less of the base tile texture to show through.

**Structure this texture with <filename>:** Applies the black and white, or luminosity values, of the pattern in the selected file with the base tile pattern. Luminosity can be adjusted from 0 to 100%.

**Color this texture with <filename>:** Uses color differences between the file you specify and the pattern on the base tile. The effect can be adjusted between 0 and 100%.

To combine a texture with another image:

1. Click the “Combine...” button in the Effects area of the Tile tab.
- or —
1. Choose “Combine...” from the Effects menu.
  2. Choose the combining process that you want to use from the pop-up list.
  3. Click the “Choose Texture” button and locate the image that you want to combine with the texture.

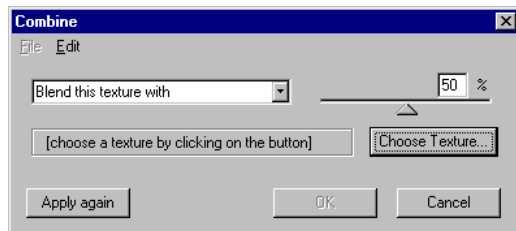
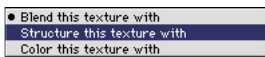
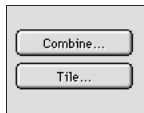

The name of the texture file you selected is displayed in the box below the pop-up.

4. Adjust the percentage of merging using the slider or by entering a value in the box. Apply the effect to see how it will look on your texture. Experiment until you achieve just the right effect.

## Changing the Number of Pattern Repetitions

---

You can change the number of pattern repetitions on the base tile by entering different matrix parameters (1x1, 3x5, 4x6 etc., up to 12x12). Be aware that doing so affects file size, which affects what happens to the texture when you apply or save it.

**To change the number of pattern repetitions:**

1. Click the “Tile...” button in the Effects area of the Tile tab.

— or —

1. Choose “Tile...” from the Effects menu.

The Tile dialog is displayed.

2. In the Horizontal and Vertical boxes, enter the number of times you want the pattern repeated on the base tile.
3. Click “OK.”

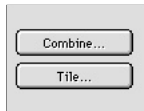

The base tile will be enlarged or reduced as necessary to accommodate the number of repetitions you indicated.

*Note: If you increase the number of pattern repetitions, base tile size is increased.*

## Resizing the Base Tile

---

You can change the size of the base tile without affecting the number of pattern repetitions. This affects both file size and the size of the pattern elements.

To change the size of the base tile:

1. Click the “Edit...” button in the File Options area of the Tile tab.

— *or* —

1. Choose “Edit...” from the File menu in the PhotoTexture menu bar.

The Edit file dialog is displayed.

2. In the Width and Height fields, enter the size that you want to change the base tile to.

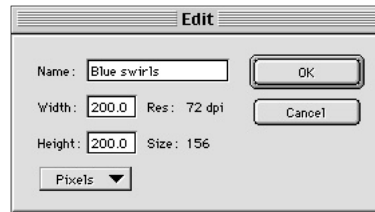
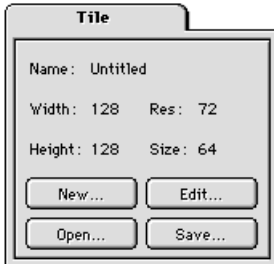

This resets the size of the base tile to the specified size. The pattern is reduced or enlarged as much as necessary to fit the new base tile size.



# PhotoEffects

---

PhotoEffects is a set of six image-enhancement tools for Photoshop that allow you to create spectacular Photoshop effects in a fraction of the time it used to take, and with much more interactive control. The six Effects plug-ins are:

- PhotoButton
- PhotoGroove
- PhotoEmboss
- PhotoCastShadow
- PhotoBevel
- PhotoGlow

Using these tools you can create professional effects on any type of graphic element, including text, with significantly less effort. See the results of your actions interactively as you tweak, twist, color, and distort to achieve just the right effect. When you've achieved the result you want, apply it to your image. You can even save your favorite effect settings and recall them for use on other images.

**PhotoButton:** Interactively create up to 64 beautifully rendered identical buttons using an array of tools to create custom buttons in all shapes, sizes, colors, and beveling.

**PhotoCastShadow:** Interactively create multiple shadows—including drop shadows and perspective shadows with realistic adjustable 3-D blurs—and see your work in a real-time preview.

**PhotoGroove:** Gain complete control over simple to complex bevel shapes with PhotoGroove's custom interactive bevel shape editor, which allows you to effortlessly create unlimited edge possibilities by manipulating quantity, shape, width, softness, and highlighting.

**PhotoBevel:** Quickly create bevel shapes in PhotoBevel using standard PhotoTools shaping tools including inside and outside bevels, highlight and shadow colors.

**PhotoEmboss and PhotoGlow:** Create custom embossing and glow effects on any image, in a fraction of the time it would take to achieve them manually.

All PhotoEffects plug-ins include a handy pop-up image navigator, editing in real time with interactive preview, multiple undos, and the ability to view composite layers—so you can see exactly how your effects will fit with the background and other image elements. Whether used individually or together, the PhotoEffects plug-ins will give you professional buttons, shadows, bevels, embossing, and glows with a minimum of effort.

## Elements Common to All Effects

---

### Tip

For a listing of keyboard shortcuts, see *Appendix A, page 174*.

Many commands and attributes are common to all of the Effects plug-ins (PhotoButton, PhotoCastShadow, PhotoGroove, PhotoBevel, PhotoEmboss, and PhotoGlow). Those common operations are described in this section. *For specific details about each of the individual plug-ins, refer to the section in this manual specific to that effect.*

All PhotoEffects plug-ins provide the following:

- **Image preview**—work with any image or selected part of an image. Experiment until you achieve just the right effect, then “apply” that effect to your image.
- **Interactive, real-time editing environment**—work with effects interactively, watching your effect take shape on a real-time Preview screen.
- **Multiple undos and redos**—go back and forth as many steps as you need to before applying your effect to the image.
- **View composite layers**—see all the active layers, not just the layer you’re working on, inside the plug-in Preview window. Allows you to see your effects in relation to the rest of the image without giving up the flexibility of layers.
- **Photoshop Actions Palette aware**—allows for easy Actions Palette scripting inside Photoshop. Dramatically increases productivity when you need to create the same effects in multiple files.
- **Navigator pop-up**—innovative “pop-out” navigator is hidden until needed. Allows you to instantly position your image in the Preview window without competing with the image for space.
- **Standard Photoshop-style interface**—no need to relearn tools and commands. All PhotoEffects plug-ins use many Photoshop-type commands, and operations behave as you’d expect them to if applied directly in Photoshop (exceptions are noted where they occur.) Zooming and scrolling controls use standard keyboard shortcuts (*see Appendix A, page 174*).
- **Save and reapply effects**—create just the effect you want, then save the settings for reuse at any time.
- **Eyedropper tool**—extract colors from the image without leaving the Preview window.
- **Background processing**—uses idle time between image adjustments to process the effect, reducing or eliminating the need for more processing when the effect is applied.
- **Fit on Preview**—fits the image to the available Preview window. Equates to Photoshop Fit on Screen command.
- **Help Box**—displays, in a special window, a description of each tool and button function as you drag the mouse over it.

## Getting Started with PhotoEffects

To create an effect using a PhotoEffects plug-in:

1. Select an area of your image where you wish to add an effect.

*Note: PhotoCastShadow and PhotoGlow require that an image area be selected, either implicitly (using a layer's transparency mask) or explicitly ("marching ants" indicating the selected area). PhotoTexture, PhotoButton, PhotoGroove, PhotoBevel, and PhotoEmboss do not.*

If you're not familiar with creating effects using a plug-in, start with something simple. Open your image in Photoshop, and using the Marquee tool, drag a rectangle around the area you wish to work with, or create a layer with the image you'll be working with on a transparent background. If no area is selected, the PhotoEffect plug-ins assume you want to work with the full image (*see Note above*).



2. Select the desired PhotoEffect plug-in.

Select a plug-in from the PhotoTools Commands toolbar, from the Extensis menu, or from the PhotoTools menu in the Photoshop Filters menu.

Select PhotoButton, PhotoGroove, PhotoBevel, PhotoCastShadow, PhotoEmboss, or PhotoGlow. The Preview window dialog box for the selected Effect will be displayed.

3. Use the options in the effects Preview dialog box to create the desired effect (the specific options for each effect are described later in this chapter).

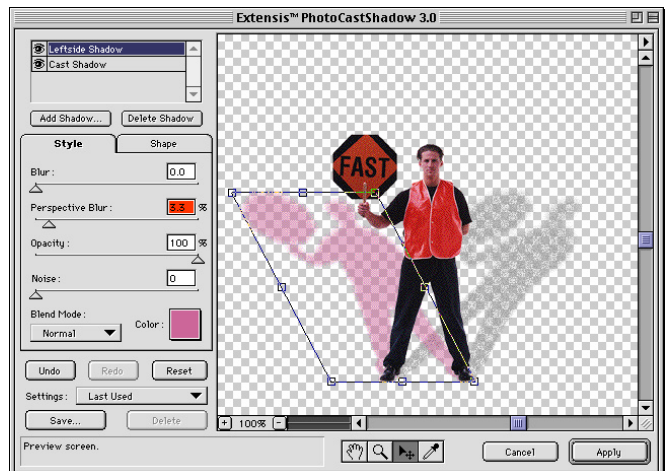
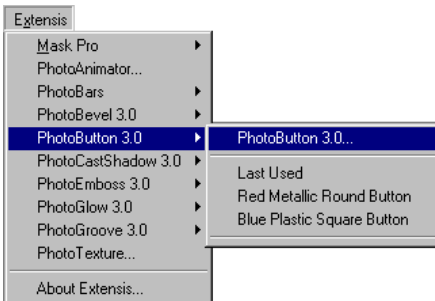

## Tip

You can apply a saved effect by selecting it in the Effect's dialog box or by selecting it from the Extensis menu. When you choose a Setting from the menu, the effect is immediately applied to the selection, without opening the Effect's dialog box.

## Tip

**Macintosh Users:** PhotoBars provides another convenient way to access effect settings saved in the PhotoEffects plug-ins: Click the Saved Effects button in the Effects Settings toolbar to see a list of all saved effect sets.

Inside each of the PhotoEffects plug-ins you can experiment with all kinds of effect parameters, and immediately see your result on the image in the Preview window.

*Note: While you are working in an Effect's dialog box (Preview window) the changes you make do not affect the image in Photoshop. When you like the effect you see in the Preview window and are ready to make those changes to your image, click "Apply." Until you click "Apply" you can change the parameters as much as you like until you get just the effect you want. If you don't like the effect you created, click Cancel and the Effect's window will close without making any changes to your image.*

If your changes don't appear in the Preview window, see "Unexpected Results" later in this chapter.

## 5. When you're satisfied with the effect you've created in the Preview window, apply the effect to your image.

Click "Apply" to add the effect to your image.

If you get any warning dialogs when you attempt to apply your changes, refer to Troubleshooting (page 176) and "Additional Information" later in this chapter.

*Note: If you accidentally Apply the effect to your image before you are completely finished (the Effect dialog box closes), you can "undo" the effect (Command-Z [Ctrl+Z]). You can then reopen the Effect—it will remember and display your Last Used settings.*

## To Save PhotoEffects Settings for Later Use:

### 1. Once you've established the settings exactly as you want them, click the "Save" button in the Effect's dialog box.

A Save dialog box appears, allowing you to name and save the current Effect's settings as a filter.

### 2. Type a name for the Settings to be saved.

### 3. Click "OK."

The name of the Settings will appear in the pop-up menu in the bottom-left corner of the dialog box. It will also be available from the Effect plug-in's submenu on the Extensis menu.

### To Use PhotoEffects Settings Previously Saved:

1. Select an area of your image on which to apply the effect.
2. Open the desired PhotoEffects plug-in.
3. Select the name of the saved effect from the Settings pop-up menu in the bottom-left corner of the dialog box.

*Note: Settings are specific to the plug-in they were saved in. For example, you cannot open PhotoCastShadow settings in PhotoBevel.*

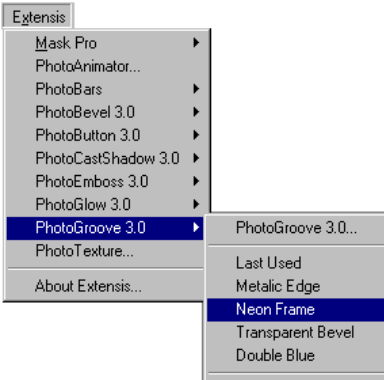

4. If desired, make any additional adjustments to the effect.
5. Click “Apply” to add the effect to your image.

— or —

1. Select an area of your image on which to apply the effect.
2. Select the saved Settings you wish to use from the Effect plug-in’s submenu on the Extensis menu.

The saved effect will be applied to the selection immediately, without opening the Effect’s dialog box.

### To Delete PhotoEffects Settings Previously Saved:

1. Select the desired PhotoEffects plug-in.
2. Locate the setting you want to delete in the Settings pop-up menu in the bottom-left corner of the dialog box.
3. Click “Delete.” You will be asked to confirm the deletion.
4. Click “OK.”

### Preset Settings

A number of common effect Settings are provided for each of the Effect plug-ins. These Settings can be used “as is” or selected and then modified. The Preset Settings cannot be removed.

### To Select a Preset Setting:

1. Follow the steps in “To Use PhotoEffects Settings Previously Saved” (*above*). The Preset Settings appear in the upper-half of the menu, above any user-created settings.



## Common PhotoEffects Elements Explained

### The PhotoEffects Dialog Box

When you select a PhotoEffects plug-in, the dialog box for that plug-in is opened. Inside this window you have access to all the tools, options, and windows needed to create, modify, experiment with, and view your effect. For details about the tools and options available for the different Effects, refer to the section of this manual specific to that Effect.

#### Typical PhotoEffects Dialog box

- A** PhotoEffects Menus: In Windows, the Effects menus are located at the top of the dialog box window. In Macintosh, the menus replace the Photoshop menus in the main menubar
- B** Title Bar: Shows the PhotoEffects plug-in currently in use.
- C** Preview window: Displays your image with the selected effects applied before you apply them to your image. Updates your changes in real time if "Real-time Preview" is turned on. Displays the composite view of all selected layers when "View Composite Layers" is turned on.
- D** Image Navigator: Click and drag in this pop-up window to instantly reposition the image in the Preview window.
- E** Effect-specific Options: These effects options will differ depending on what PhotoEffects plug-in is being used.
- F** Settings: These tools allow you to Select, Save, and Delete effect settings. Only settings appropriate to the current PhotoEffects plug-in will be available in the list.
- G** Help Box: Describes each function as the mouse passes over it.
- H** Undo/Redo/Reset: Undo/Redo provides multiple undos and redos; Reset returns all settings to their default values (useful for starting over "from scratch").
- I** Zoom Controls and Indicator: Changes and displays zoom amount.

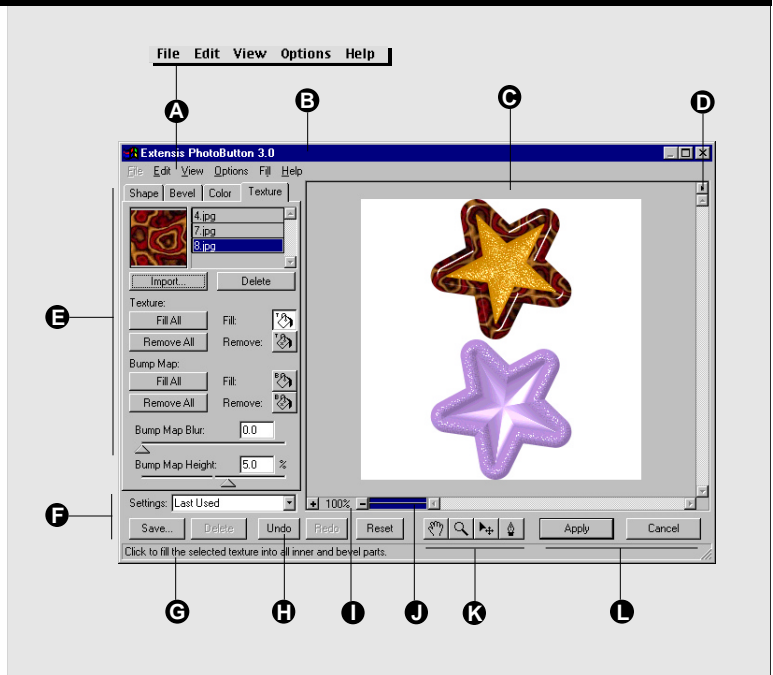

- J** Progress Indicators: Top bar shows Preview Redraw progress. Bottom bar shows Background Processing progress when the "Background Processing" option is turned on.
- K** Effect-specific Tools: These tools may differ depending on what PhotoEffects plug-in is being used. Scroll (Hand) and Zoom (Magnifying glass) are available in all Effects.
- L** Cancel/Apply: Apply closes the dialog box and applies your effects to the image in Photoshop. Cancel closes the dialog and leaving the image unchanged.

## Undo/Redo/Reset

All of the controls in PhotoEffects provide multiple undo and redo capability using the Undo/Redo buttons in the Effect's dialog box, selecting Undo/Redo from the menu, or using keyboard shortcuts. Reset returns all settings to the default condition, allowing you to start over in a known state.

### To Undo a Command:

1. **Click Undo as many times as needed to undo steps.**

Choose Edit > Undo (or press **Command-Z [Ctrl+Z]**).

The Undo button is dimmed if there are no operations to undo.



### To Redo a Command:

1. **Click Redo as many times as needed to restore previous undo(s).**

Choose Edit > Redo (or press **Command-Y [Ctrl+Y]**).

The Redo button is dimmed if there are no operations to redo.

### To Reset all Effects:

1. **Click Reset.**

All effect settings, undos, and redos for the current session will be restored to factory defaults. The Preview image will be displayed with no other effects applied.

#### Tip

You CAN “undo” a Reset.

## View Composite Layers

With the View Composite Layer feature you can see all visible layers—not just the layer you’re working on—inside the Effect Preview window. This allows you to see your effects in relation to the rest of the image without having to flatten the layers.

### To View Multiple Layers in a PhotoEffects Preview:

1. In Photoshop, verify that all the layers you want to see in the image Preview window have been made visible (eye icon showing in the layers palette).
2. Select the image area that you wish to create an effect for.
3. Select the PhotoEffects plug-in for the effect you wish to create.

This opens the plug-in Preview window dialog box. You should see all the layers along with your image.

4. If you do not see the layers along with your image, choose **View > View Composite Layer**.

This enables the View Composite Layer function. (This option is turned off by default when PhotoTools is installed.) Or press **Command-L [Ctrl+L]**.

*Note: If the image does not appear to preview correctly after performing the steps above, see Additional Information on page 46 and Troubleshooting on page 176.*

## Fit on Preview

Fit on Preview adjusts the zoom percentage to the largest size that can fit in the Preview area and still contain the entire image. Actual Pixels returns the Preview to the actual pixel size prior to invoking Fit on Preview.

### To Fit the image to the Preview window:

1. Select **View > Fit on Preview** (or press **Command-0 (zero) [Ctrl+0 (zero)]**).

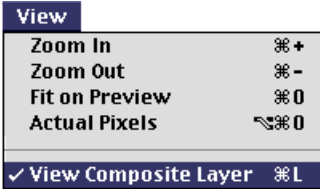

### Tip

You can toggle View Composite Layer on and off from inside the Effect’s Preview window with **Command-L [Ctrl+L]**.

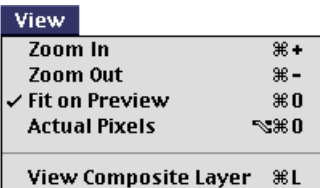



## Real-time Preview

The Real-time Preview feature allows different effects to be applied and viewed *as you change them*. This means you get immediate feedback in your preview as you adjust the parameters of an effect.

One of the most striking examples is in the Color Palette. In a typical program, you would click-open the Color Palette, choose a color, release the pop-up, then wait for the preview to display the effect in that color. To try a different color, you would have to go through the whole color-selection process again. With the Effects plug-ins, you simply click-open the palette and drag the mouse over the color chips. Each time you drag the mouse over a different color chip, the preview updates immediately in real time.

For example, with Real-time Preview *on*, if you are creating a cast shadow and want to experiment with shadow coloring, press and hold the Color Palette pop-up as you drag the mouse around—the Preview image immediately shows the shadow in the color you chose, and the shadow color will change as you drag your mouse over the different colors. Try turning Real-time Preview *off* and see the difference!

*Note: You can also preview colors interactively by selecting the Eyedropper and dragging it around the Preview window.*

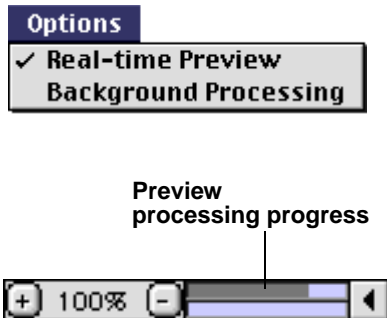

### To Turn Real-time Preview On or Off:

#### 1. Choose Options > Real-time Preview.

A checkmark indicates that Real-time Previewing is On.

Whether or not you have Real-time Previewing turned on, the Preview image must be processed and redrawn when you change an effect option. This redraw is tracked on the top half of the dual progress bar located just underneath the Preview window. The Preview is not completely finished until the progress bar reaches the end.

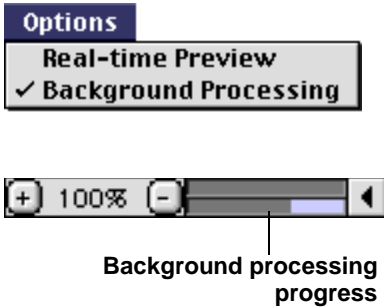

## Background Processing

In a typical Preview scenario, when you are finished with preview mode and want to apply your changes to the image, more processing is required before the image window reappears. To speed things up, PhotoEffects uses the idle time between your image adjustments in the Preview window to begin final processing. As soon as you stop adjusting controls, final processing begins, and a progress bar is displayed just below the Preview window. If the progress bar is complete (indicating that processing is complete) when you Apply the effect, the image screen will appear much more quickly.

### To Turn Background Processing On or Off:

1. **Choose Options > Background Processing.**

A checkmark indicates that Background Processing is On.

## Zooming and Panning

All PhotoEffects plug-ins provide a number of easy ways for navigating and viewing effects in the Preview window.

### To Zoom In:

- **Click the “+” button under the Preview window.**

Each click magnifies the image to the next percentage. Zooming occurs from the center of the image. When you reach maximum magnification, the center of the Zoom tool appears empty.

— *or* —



- **Select the Zoom tool (magnifying glass), then click the area of the image you want to magnify.**

Each click magnifies the image to the next percentage, and the magnified display is centered around the point you click.

— *or* —

- **Press Command-Shift-“+” or Command-Keypad “+” [Ctrl+Keypad “+”].**

— *or* —

- **Choose View > Zoom In from the menubar.**

### To Zoom Out:

- **Click the “-” button under the Preview window.**

Each click reduces the image to the next percentage. Zooming occurs from the center of the image. When you reach maximum reduction, the center of the Zoom tool appears empty.

— *or* —

- **Select the Zoom tool (magnifying glass). While pressing Option (Macintosh) or ALT (Windows), click the area of the image you want to reduce.**



Each click reduces the image to the next percentage.

— *or* —

- **Press Command-Shift-“-” or Command-Keypad “-” [Ctrl+Keypad “-”].**

— *or* —

- **Choose View > Zoom Out from the menubar.**

Zoom In



#### Tip

**Macintosh Users:** To momentarily switch to the Hand tool, hold down the Spacebar.

To momentarily access the Zoom tool when the Hand tool is active, press **Command** (Zoom In) or **Option** (Zoom Out).

*Note: These commands work together: With any tool selected, press Spacebar to activate the Hand tool, then also press Command or Option to access a Zoom tool.*

Zoom Out

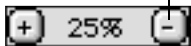

#### Tip

**Double-click** the Zoom tool to zoom to 100%.

### To Pan (Scroll) in the Preview Window:



Select the Hand tool and drag the image until you locate the area you wish to view.

— or —

- With any other tool selected (Macintosh only), press Spacebar while you drag the image in the window.

### Tip

Double-click on the Hand tool to force the Preview image to fit the available window (Fit on Preview).

### Navigator Pop-up

This handy little navigator window “pops-out” from the upper-right corner of the Effect’s Preview window (except PhotoButton), allowing you to instantly reposition your image within the window. The navigator stays out of the way until you need it, but is instantly available when you do.

### To Use the Effect’s Preview Window Navigator:

1. Click and hold the mouse over the Navigator button in the upper-right corner of the Preview window.
2. Keep holding the mouse button down as you drag the view box around the Navigator window.
3. When the image area you want to see appears in the Preview window, release the mouse to close the pop-up.

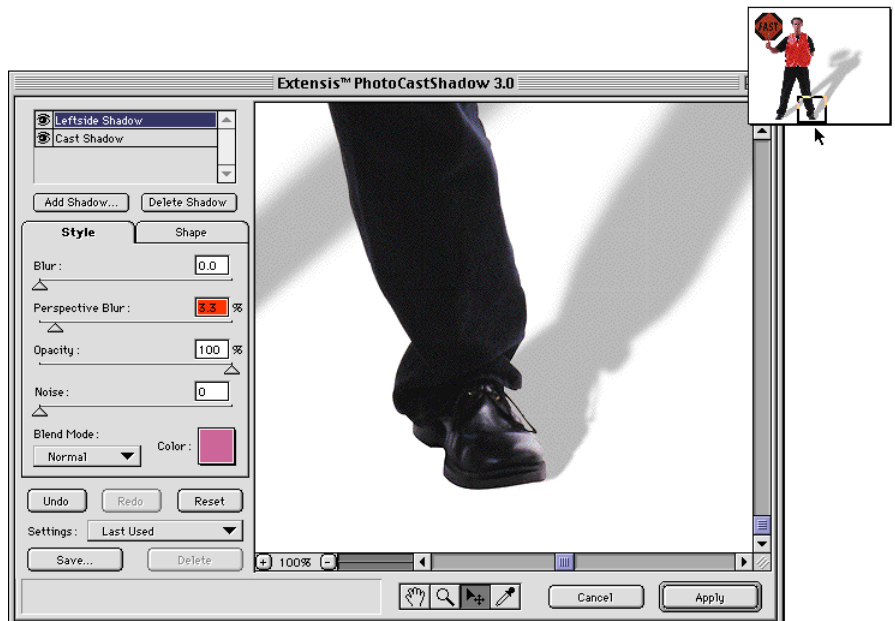

## Color Tools

**Color Pop-up:** Provides interactive access to the current Color Palette, the current Photoshop Foreground and Background colors, and the Color Picker. Color values are shown on the right side of the palette, reflecting both the current Color Mode (RGB, CMYK, etc) and the color values of the highlighted color.

*Note: In RGB mode, the Color pop-up displays all and only “web-safe” colors. This does not mean that the final result color will be web-safe, since colors may sometimes be blended and/or faded to the background.*

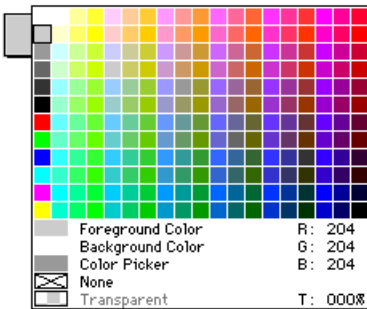

*Note: None and Transparent are PhotoButton only parameters and will be grayed out in the other PhotoEffects plug-ins. For information on these selections refer to the PhotoButton section of this manual.*

### To Preview Colors Interactively Using the Color Pop-up:

1. Click and hold on the color indicator box.
2. Drag the cursor over the color swatches in the window and observe the changes in the effect's color.

**Eyedropper:** Provides interactive access to colors in the Preview window.



### To Preview Colors Interactively Using the Eyedropper:

1. Select the Eyedropper tool.
2. Drag the Eyedropper around in the Preview window and observe the changes in the effects' color.

### To Select a Color Using the Eyedropper:

1. Select the Eyedropper tool.
2. In the Preview window, click the Eyedropper on the color you wish to select.

The selected color will appear in the color box.

## Additional Information

This section details some of the more intricate features of the PhotoEffects plug-ins. If you're already familiar with Photoshop, this information can help you avoid unexpected results when working with these ground-breaking plug-ins.

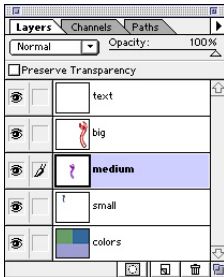

Layers palette: “text” is the top layer, “medium” is the selected layer

### View Composite Layer

The “View Composite Layer” feature allows you to see all of your visible Photoshop layers while creating your effect, something no other plug-in has allowed you to do. This is an extremely powerful feature, but current limitations with the Photoshop Application Programming Interface prevent it from working exactly as you might expect.

**How it works:** If you choose any layer other than the top-most layer as the target for your effect, the PhotoEffects plug-ins (PhotoCastShadow, PhotoGroove, PhotoButton, PhotoBevel, PhotoEmboss, or PhotoGlow) display the selected layer *as the top layer* in the Preview window; the effect is applied to this selected layer.

**Example:** In the composite image shown, the layer named “text” is the top layer. We have selected the layer named “medium” (which is below the “text” layer) as the active layer. We’ll use the image on that layer to create our effect.



Photoshop composite image:  
Top layer displays on top

When the PhotoEffect plug-in Preview window is opened (we’ve selected PhotoCastShadow), you would expect to see the image in the Preview window exactly as it appears in Photoshop—with all layers in the correct relationship. That is, with the “text” layer above and the “medium” layer below. However, this is not what happens: the selected layer, “medium,” Previews on top.

In order for the PhotoEffects plug-ins to display any composite preview correctly in all cases, your selection layer must be the top layer. But even if your selection is not the top layer, be assured that PhotoTools is not actually rearranging the layers in your image, only the Preview. If you select the top layer before opening an effect, the preview behaves normally.

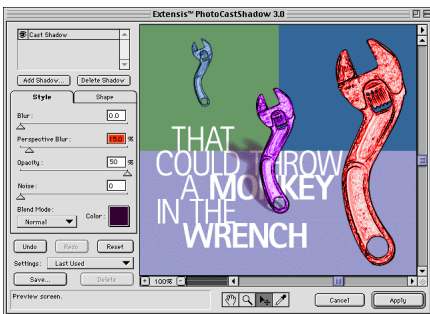

PhotoEffects Preview composite image:  
Selected layer displays on top

## Create Shadow Only / Create Glow Only

Create Shadow Only (and Create Glow Only) is a feature in the shadow-effect plug-ins, PhotoCastShadow and PhotoGlow. This feature allows you to create the effect you want and then separate it from the image, so that the shadow occupies its own layer. You may even want to delete the original image, keeping only the shadow image.

You can do this easily with PhotoCastShadow and PhotoGlow by first duplicating the layer you want to create a shadow-only effect for before you open the Effect plug-in.

**How it works:** When you turn on the “Create Shadow Only” checkbox, the preview brings the shadow forward. The Preview is designed this way to give you a visual clue that you are not just adding a drop shadow to the original information on the targeted layer. Rather, the preview is showing you that you are actually turning the targeted layer into a shadow.

**Example:** If you wanted to make a cast shadow for the big wrench, you would duplicate its layer, activate the layer, then open PhotoCastShadow. Next you would set all the parameters for your shadow, such as opacity, color, edge blur, etc. When you have the shadow looking the way you want it to, you would turn on the “Create Shadow Only” checkbox and then click Apply.

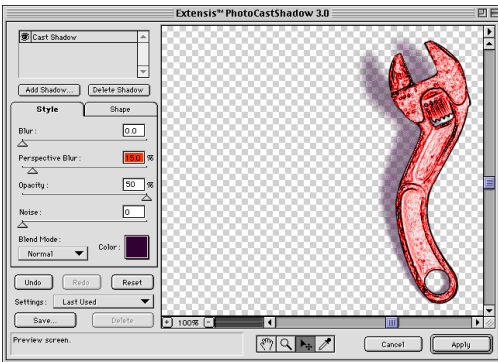

**Image and Shadow**

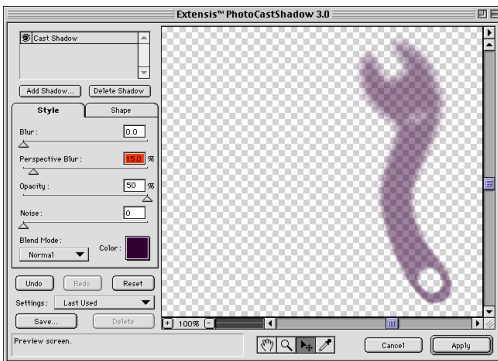

**Shadow Only**

By default, PhotoTools always keeps the original information on the targeted layer and then adds the shadow outside (or around, in the case of a glow effect) the original image. By duplicating the layer first, you no longer need to keep the original image pixels intact. Just select Create Shadow Only, and the image on the targeted layer will be transformed into a shadow, on its own layer, separate from the original layer that you duplicated beforehand!

After choosing Apply, the effect lands on its own layer where you can change the opacity, position, and blend mode without altering the original image you had before creating the effect.

## Actions Palette Awareness/Actions Palette Scripting

PhotoCastShadow, PhotoBevel, PhotoEmboss, PhotoGlow and PhotoGroove are Actions Palette aware and Actions Palette scriptable. PhotoButton and PhotoTexture are Actions Palette aware but not scriptable.

*For detailed information on Actions Palette awareness and Actions Palette scripting, refer to your Adobe Photoshop User Guide.*

## Multiple Undos and RAM

All of the PhotoEffects plug-ins allow you to Undo effects applied in the Preview window multiple times, then Redo as many of those steps as you like. This feature allows you to experiment with effect actions, reverting back to earlier actions, then moving forward to latter actions to compare different effects, or to change your mind without “losing” any work in the process.

As you might expect, Undo and Redo work only inside the effect plug-in, and effect actions are only captured for one session at a time.

The amount of RAM memory available to Photoshop will impact how many times you can Undo and Redo effect actions. Naturally, the more RAM the better, but even with Photoshop’s recommended RAM settings you’ll have access to dozens of levels of Undo.

*Note: For best performance, Photoshop recommends that you do not use virtual memory software when running Photoshop, but rather allow Photoshop to manage memory. Refer to the Adobe Photoshop User Guide for more information.*

## Color Modes

Not all color modes are available in all PhotoTools plug-ins.

- |  |   |   |  |
|--|---|---|--|
| <ul style="list-style-type: none"><li>• RGB</li></ul>                      | } | PhotoTexture supports RGB only                                      |  |
| <ul style="list-style-type: none"><li>• CMYK</li></ul>                     |   | }   | The rest of the PhotoEffects plug-ins work in all of these modes |
| <ul style="list-style-type: none"><li>• Multi-channel</li></ul>            |   |   |  |
| <ul style="list-style-type: none"><li>• Grayscale</li></ul>                |   |   |  |
| <ul style="list-style-type: none"><li>• Duotone</li></ul>                  |   |   |  |
| <ul style="list-style-type: none"><li>• Bitmap</li><li>• Indexed</li></ul> | } | No Photoshop plug-ins work in these modes                           |  |
| <ul style="list-style-type: none"><li>• Lab mode</li></ul>                 | — | PhotoGroove, PhotoButton, and PhotoTexture do not work in this mode |  |



# PhotoButton

*Note: Many controls, options, and commands are common to all the PhotoEffects plug-ins. For detailed information on those elements, refer to “The PhotoEffects Plug-ins” starting on page 33.*

## Tip

For a listing of keyboard shortcuts, refer to *Appendix A, page 174*.

With PhotoButton, you can quickly construct beautifully-rendered, uniform buttons from 15 predefined, completely customizable shapes, or design and save your own custom button shapes and edit those shapes at any time. Create button groups or single buttons, then customize by adding simple or complex custom bevels, textures and/or bump maps, and highlights. Add colors to your buttons as a group, or apply different colors to different buttons. Constructing buttons with PhotoButton saves tremendous time over “hand-rolling” individual buttons—making it the perfect tool for Web and multimedia interface projects.

## The PhotoButton Dialog box

- A** Shape Tab: Provides access to shaping options. *See page 50.*
- B** Bevel Tab: Provides access to bevel options for the buttons. *See page 51.*
- C** Color Tab: Provides access to options for the inner, outer, and bevel areas of the buttons. *See below.*
- D** Texture Tab: Provides access to button texture options. *See page 53.*
- E** Preview Window with Grid displayed. To toggle the grid on or off, press **Command-“ [Ctrl+”]**.
- F** Paint Color: Determines the color to be applied to the button parts. Use the Paint Bucket to apply this color to the selected part of any button individually. Use modifier keys to apply this color to the selected part of all buttons simultaneously (*page 68*).
- G** Inner, Bevel, and Outer Tabs: Provides access to separate Surface Property controls for the Inner and Bevel parts of the button, and the button Outer area (button background). *See page 52.*
- H** Highlighting: Controls the light source. Parameters that can be affected are Color, Direction, and Inclination. Use the control knob on the directional model to change Direction and Inclination simultaneously. *See page 70.*
- I** Settings Controls: Select, Save, and Delete effect settings.
- J** Help Box: Displays a description of each tool or option as the mouse passes over it.

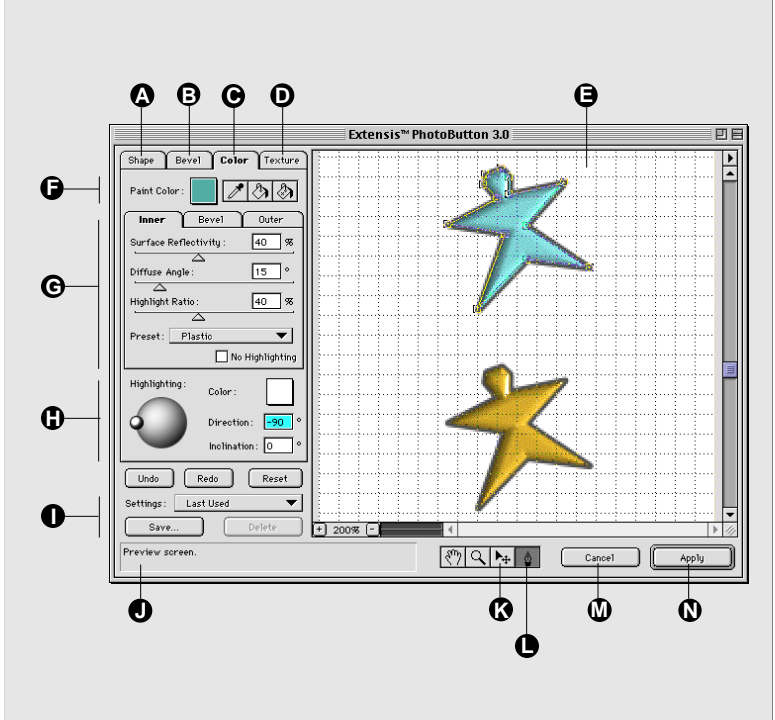

- K** Adjust (Resize) tool: Adjust Anchor Button size and position (affects all buttons).
- L** Pen (Reshape) tool: Adjust Anchor Button shape (affects all buttons). Add and delete anchor points, drag points and lines.
- M** Cancel: Closes the dialog box without making changes to the image. You can also Cancel by pressing **Command-“.” (period) [Alt+F4]**.
- N** Apply: Adds your selected effects to the image and closes the dialog box. You can also Apply the effect by pressing Return or Enter.

## PhotoButton Shape Tab

The Shape tab provides access to all shaping options for the buttons. Values changed using the Adjust tool and Pen tool will be displayed in the appropriate fields.

### A Shape tab

**B** Number: Specify number of buttons in rows (horizontal) and number of buttons in columns (vertical).

**C** Width and Height: Specify Anchor Button size, in pixels (affects all buttons).

Lock/Unlock: When lock is on, constrains button size to values entered in the Width and Height parameter boxes.

**D** Shape: Choose from saved custom shapes and 15 common, predefined shapes.

**E** Save/Delete: Click Save to name and save the current shape, and add it to the Shapes list. *Note: Saving a shape does not save any other button parameters. To save all button settings, save using the Settings options (see page 36).* Click Delete to remove the currently selected shape from the list.

**F** Rotation Angle: Rotates all the buttons. Rotation is not applicable to all shapes (for example, Circles). *Note: When Rotation Angle is adjusted, all manual resizing and repositioning is undone.*

**G** Corner Radius: Controls curve of button corners. *Note: When Corner Radius is adjusted, all manual resizing and repositioning is undone.*

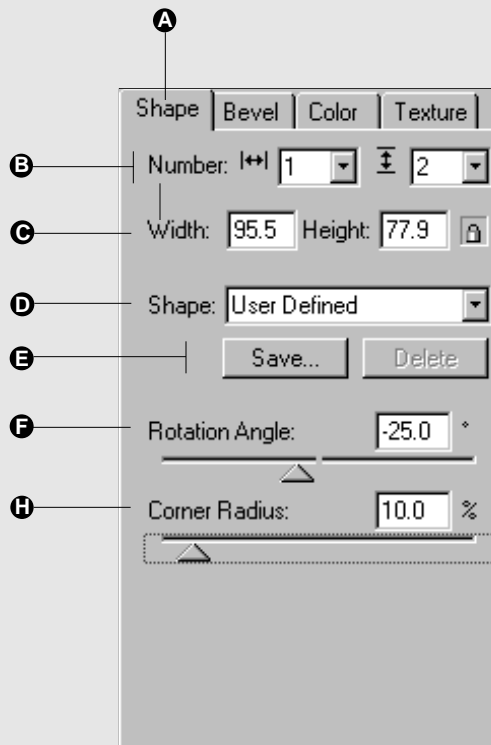

## PhotoButton Bevel Tab

The Bevel tab allows you to create custom bevel effects for the buttons. Options on the Bevel tab apply to all the buttons. Use the bevel settings found on this tab along with the bevel color and highlighting control on the Color:Bevel tab to achieve just the right effect.

**A** Bevel tab

**B** Shapes Thumbnail: Displays a thumbnail representation of the shape as shown on the Bevel Shapes palette.

**C** Save: Allows you to name and save the current shape. When saved, the new shape appears on the Shapes Pop-up Menu (**D**). (This options saves only the bevel Shape. To save bevel style parameters, you must create a Settings (page 36).

**D** Shapes Pop-up Menu: Access all pre-defined and saved bevel shapes.

**E** Bevel Shape Editor: Clicking the button opens or closes the Bevel Shape editing palette. Click to add a new edge. To change edge spacing and height, drag the point to a new position on the grid.

New points are automatically created as Smooth points. To create a sharp, pointed edge, click the "Pointy" box and then click on the graph to add the point. To change a Smooth point to a Pointy point, select the point and check the Pointy box. To change a Pointy point to a Smooth point, select the point and uncheck the Pointy box.

**F** Delete:Deletes the selected Shape.

**G** Bevel Width: Controls bevel width.

**H** Bevel Height: Adjusts bevel lighting to make the button look shorter, taller, more convex or more concave.

**I** Bevel Softness: Softens the edges of the bevels.

**J** Inner Height: Makes the inner part of the button convex or concave. 100% is maximum convex, 0% is flat.

*For more detailed information on the Bevel Shape editing palette, refer to page 62.*

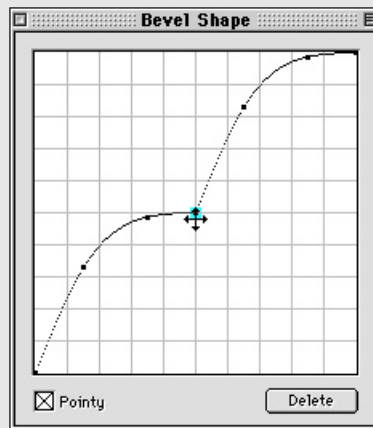
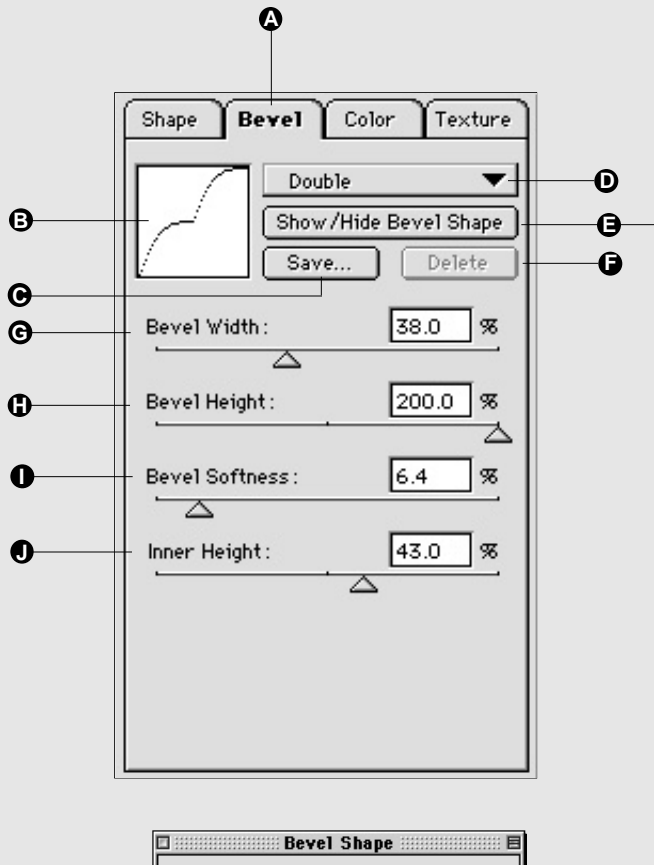

## PhotoButton Color Tab—Surface Property Tabs

The Surface Property tabs, consisting of the Inner and Bevel button parts, and button Outer area, provide access to color surface property settings for the three parts individually. Values shown in the tab affect the selected part of all buttons in the matrix.

- A** Inner Tab: Specify color parameters for the inner area of the button.
- B** Bevel Tab: Specify color parameters for the bevel area of the buttons.
- C** Outer Tab: Specify color parameters for the area outside of the buttons.
- D** Surface Reflectivity: Controls the amount of light reflected or absorbed. 0% yields a matte (all light is absorbed, no reflection); 99% yields a high gloss (very reflective). See *Note under Highlight Ratio*.
- E** Diffuse Angle: Controls the degree to which light is diffused on the surface. 1% yields a focused, spotlight effect; 90% yields a diffused wash of light.
- F** Highlight Ratio: Controls the amount of light striking the button part (similar to using a dimmer switch). *Note: If the Highlight Ratio is set to zero (indicating no light) there can be no surface reflectivity.*
- G** Preset: Sample settings showing common effects achieved by changing the various Surface Property parameters.

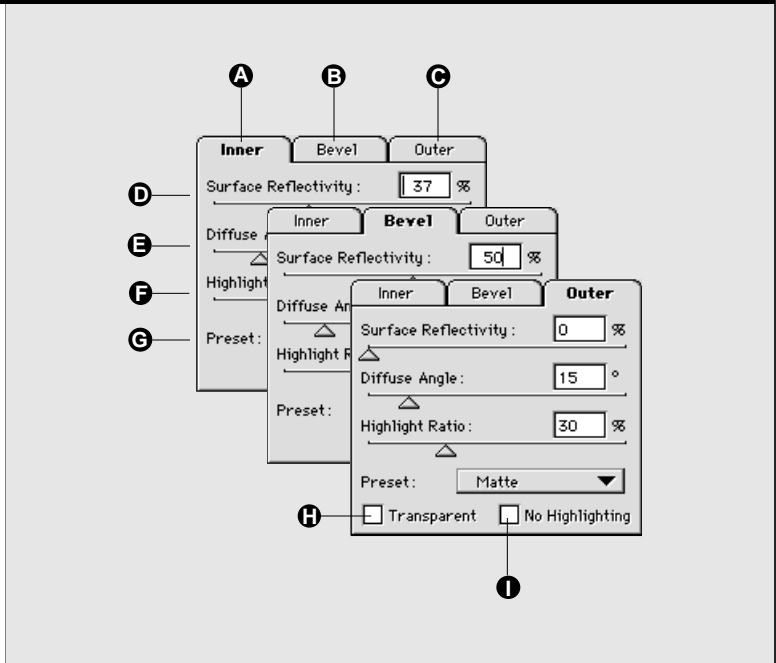

**H** Transparent: Applies to Outer button part only. When on, makes all the pixels outside the button transparent. (See Note on page 70.)

**I** No Highlighting: When on, no light strikes the selected button part. Disables the color controls. (Same effect as setting all three color controls to their minimum values.)

## PhotoButton Texture Tab

The Texture tab provides access to all texture options for the buttons, including regular textures and bump map (raised or stamped) textures. Listed texture files are saved in the PhotoButton preferences and will be available whenever you open PhotoButton.

- A** Texture tab
- B** Texture Thumbnail: Displays a thumbnail preview of the selected texture.
- C** Import: Allows you to locate and import JPEG (.jpg) files to be used as textures or bump maps.
- D** Texture Fill All / Remove All: Click Fill All to apply the selected texture (from the Textures list) to all parts of all buttons at once. Click Remove All to remove the selected texture from all parts of all buttons at once.
- E** Bump Map Fill All / Remove All: Same as Texture Fill All / Remove All (D), except applies to Bump Maps.
- F** Bump Map Blur: Softens transitions in the bump map.
- G** Bump Map Height: Adjusts bump map lighting to make the bumps look shorter, taller, more convex or more concave.
- H** Textures List: Displays all the alpha channels and JPEG files currently available. Select a texture from the list, then use either the Texture or Bump Map Bucket tool to apply the image to the button(s) as either a texture or bump map.

**JPEG Files:** You can add JPEG files to the list by importing them using the Import button, or by dragging and dropping from the desktop.

**Alpha Channels:** Any alpha channels in the file being used to create the buttons will automatically appear at the top of the list to be used as textures or bump maps. You can delete Alpha Channels from the list, but you cannot add them.

- I** Delete: Click to remove the selected JPEG file (.jpg) from the Textures list.
- J** Bucket tools: The Bucket tools allow you to apply a Texture or Bump Map to individual buttons or areas of a button (inner/bevel/outer). You use a different Bucket tool to apply selected textures as a Bump Map. The top Bucket in each section adds the indicated effect, the bottom bucket (with Xs) removes the effect.

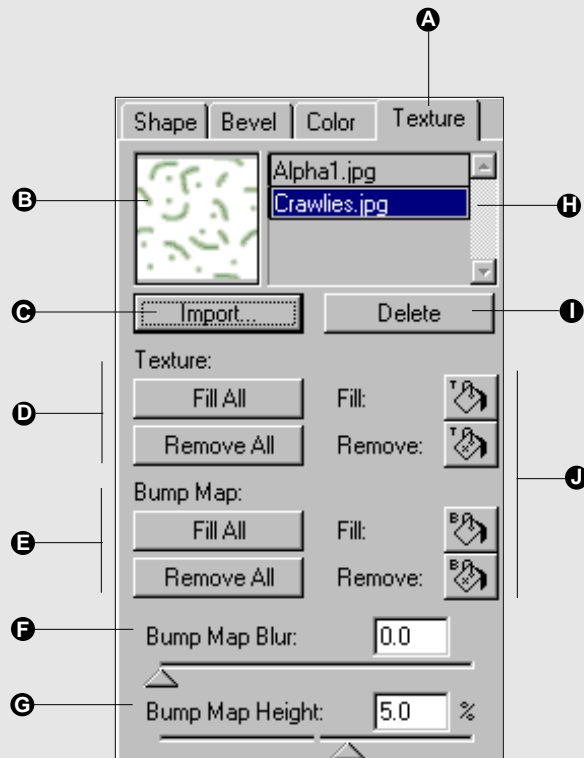

## Getting Started with PhotoButton

---

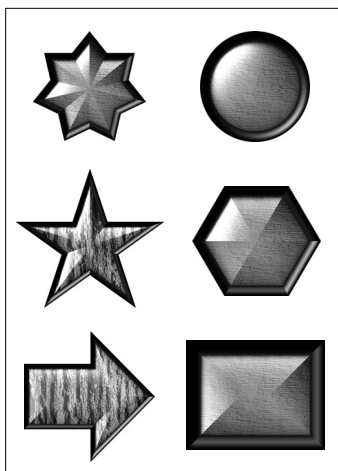

Sample Buttons Created  
in PhotoButton

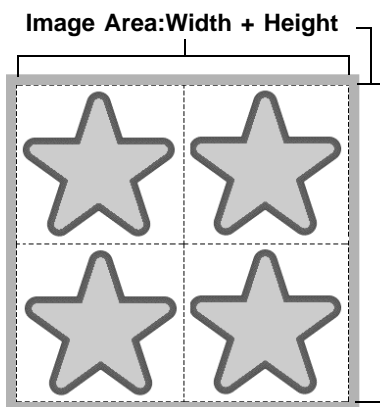

Button Matrix

PhotoButton allows you to automatically create a matrix of same-shape buttons using a single “Anchor Button” as the copy source. As you work with the Anchor Button, selecting and adjusting the shape, contour, bevels, and texture to achieve just the right effect, you will see the effect on all the buttons automatically. Use the color controls to set reflectivity, diffusion, and highlighting, coloring all buttons the same, or optionally color each button individually.

This section will help you understand how the different parameters interact. For instructions on how to create buttons and add textures to them, refer to the tutorial starting on *page 167*.

### Image Area

When you open PhotoButton, a maximum Image Area is set. The Image Area is the maximum area, Width + Height, that your button matrix can occupy. You specify the image area either explicitly by selecting an image area before opening PhotoButton, or implicitly by opening PhotoButton on any layer, image, or window.

The image area selected when PhotoButton is opened will be the maximum area you can work with for that PhotoButton session. As you determine how many buttons will be in your matrix, and how big each button will be, the total Image Area will automatically be partitioned into equal parts to accommodate your choices.

Your button size will be constrained by how many buttons you want in the matrix. Conversely, how many buttons you choose for the matrix will constrain how much space each individual button will occupy. For example: If you select a 100 pixel by 100 pixel area, and you wish to have 2 rows and 2 columns of buttons, each button can be no larger than 50 pixels x 50 pixels.

### Setting the Initial Parameters: Number, Size, and Shape

When you initially open PhotoButton, you must indicate how many buttons you wish to work with and how those the buttons will be arranged (rows and columns). This sets the parameters for the Button Matrix. (*Note: A matrix can be composed of a single button, indicated as 1 across and 1 down*).

You may also choose to set the Width and Height of each button. Since all buttons in the matrix will have identical shapes, the Width and Height specification applies to all the buttons.

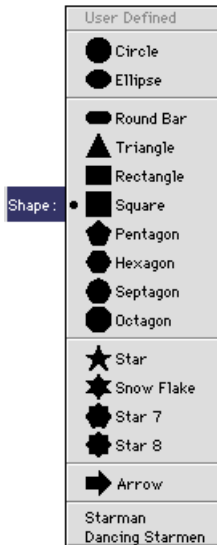

Once the matrix parameters have been set, changing the number of buttons will affect both the size and spacing of the buttons, unless your settings are size protected. If you do not want your button size to change (until you indicate a change by entering new values in the Width and Height boxes, or by manually resizing with the Resize tool), you can the lock the Width and Height by clicking on the lock icon (*see page 57*).

You can select a shape for the button from the Shape pop-up menu on the Shape tab at any time, modify a predefined shape, or create your own custom shape and add it to the list. As soon as you select a shape you can immediately see how the different button parameters you've set (such as color, bevels, texture) will affect it. Remember that your results will be impacted by whether or not you lock the button size.

### The Anchor Button

Once you have established the parameters of the matrix (button number, arrangement, size, and basic shape), you will work with one button and PhotoButton will automatically apply your changes to all the other buttons. This primary button is called the Anchor Button because all the other buttons are “anchored” to this button. If you reposition or resize the Anchor Button, all the buttons are repositioned and resized.

The Anchor Button (*see the figure on page 56*), is always the first button in the matrix, located in the upper-left corner of the button matrix. When you select either the Adjust (resize) tool or the Pen (reshape) tool, the bounding box and handles that allow you to work with the button will always be shown on the Anchor Button. These button moving, sizing, and shaping tools are described in “Positioning, Sizing and Shaping” on page 58.

### Button Size

Since the Image Area (*see the figure on page 54*) is divided equally among the buttons in the matrix, it is more accurate to think of button “size” as the total area, Width + Height, that the button will occupy. This would include a share of the space between a button and its surrounding neighbors. So the space between buttons is not “empty” space—it is an integral part of the button.

*Note: You can create the illusion of empty space between buttons by coloring the outer part Transparent or None (no color). Refer to page 67 for more information on the Transparent and None options.*

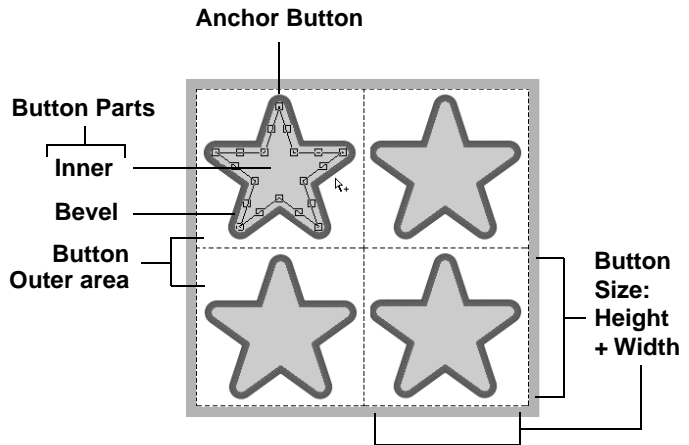

### Button Parts

Each button is composed of two parts: the Inner area and the Bevel area. The Outer area is all the space outside the buttons. Surface parameters, such as color, reflectivity, diffuse angle and highlight ratio, can be defined separately for each of the button areas.

**Inner area:** The Inner area of the button is the space inside the button extending up to the Bevel area. Changes in Bevel Width or Corner Radius will affect the size of the Inner area.

**Bevel area:** The Bevel area of the button completely surrounds the Inner area. It provides the boundaries of what you might commonly think of as the button itself, not taking into account the space around the buttons.

**Outer area:** The Outer area consists entirely of the space between and around each button, including any space between the button and the outermost edges of the Image area. The Outer area will change as buttons are resized and reshaped. Color is applied to the entire Outer area at once, not on a button by button basis, as the with the Inner and Bevel areas.



## Locking the Button Size

If button size must remain constant (for example, your buttons all must be 50 pixels by 50 pixels), you can “lock” them to that size using Size Lock/Unlock. Without the lock on, PhotoButton assumes that you want to fill the available space with buttons, and sizes the buttons accordingly.



When the Size Lock is on, changing the Number, Shape, Rotation Angle, or Corner Radius does not affect button size. The buttons can still be resized manually using the Resize tool, or by typing in values in the Width and Height parameter boxes.



When the Size Lock is off, changing the Number, Shape, Rotation Angle, or Corner Radius will undo all manual resizing, and the buttons will be resized to entirely fill their section of the image area.

*Note: When the lock is on, increasing the number of buttons will decrease the space between them. If a particular number of buttons will not fit on the canvas without resizing the buttons, that number will be grayed out in the Number pop-up menu.*

**Before: 3x3 Matrix**

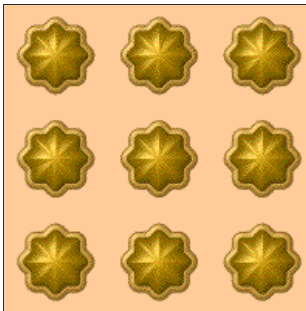

**After:  
2x3 Matrix**

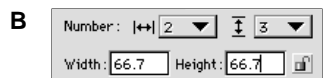
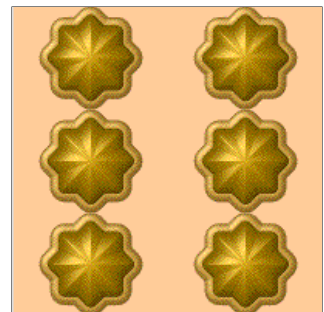
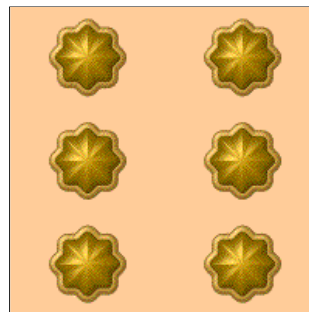

**Example:** We started with a canvas 200 pixels square, then created a 3x3 matrix of buttons specifying that each button be 50 pixels wide by 50 pixels high. This is shown in the figure on the left.

We then decided to change to a 2x3 matrix. In the figure on the bottom-left (**A**), we locked in the button size with the Size Lock, then selected “2” from the Rows pop-up. In the figure on the bottom-right (**B**), we did not lock in the button size before selecting “2” from the Rows pop-up. Notice that when button size is locked, the Outer area (space) grows to fill the Image Area. When the button size is not locked, the buttons grow to fill the Image Area.

## Positioning, Sizing, and Shaping

The button matrix can occupy all of, or any part of, the total Image Area. The matrix can be moved about in the Image Area, and the buttons can be resized and reshaped. However, individual buttons cannot extend outside of their part of the button matrix.

**Positioning:** All buttons in the matrix move in relationship to the Anchor Button, regardless of the number, shape, or size of the buttons.

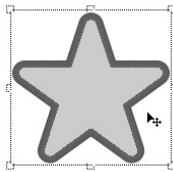

**Adjust (Resize and Reposition) Tool**

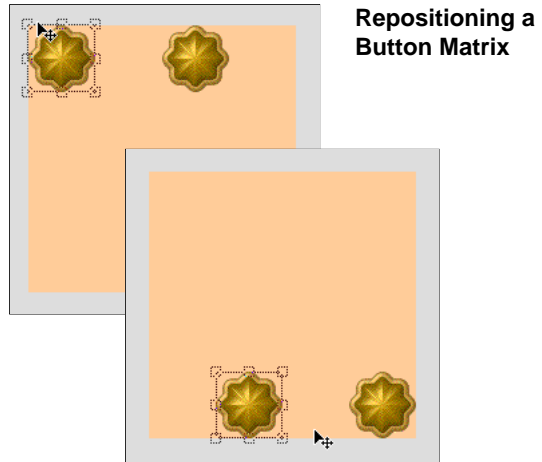

**Adjust tool:** The Adjust (reposition and resize) tool can be used to reposition and rotate the buttons within the matrix, and to interactively change the Width and/or Height of the buttons. As the Anchor Button is repositioned or resized, all of the other buttons will follow.

*Note: Adjusting Corner Radius or Rotation Angle, or choosing a new shape from the Shape pop-up, will cause any manual resizing (with the Adjust tool) to be undone.*



**Pen tool:** The Pen tool can be used to add and remove points for shaping the Anchor Button, and to reshape, stretch and distort it. Drag a corner handle to change the length and angle of the sides. Drag a side handle to move the entire side without changing its length or angle.

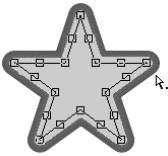

Pen (Shaping) Tool

Reshape from Corner

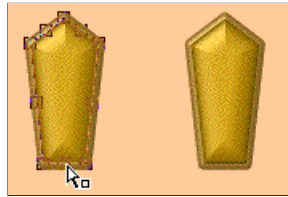
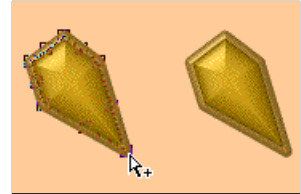

Reshape from Side

To...	With the Pen tool active...
Add an anchor point	Option-click [Alt+click] on an existing line (⌘+.) or double-click an existing line (⌘.)
Delete an anchor point	Option-click [Alt+click] an existing point (⌘+) or double-click an existing point (⌘.)
Reposition a line	Drag the line (⌘.)
Reposition a point	Drag the point (⌘.)
Undo last drag	Command-Z [Ctrl+Z]

## Creating Custom Shapes

You can create and save as many button shapes as you like, and later select them from the button Shape pop-up menu. To create new shapes you start with an existing shape, then use the Pen tool to add or remove points, and to drag points and lines to new positions as required to create the new design.

### To create a Custom Button Shape:

1. Select the Shape tab by clicking it.
2. From the Shape pop-up menu, select a shape that is similar to the shape you want to create.
3. Select the Pen tool. Position the Pen tool over a point (Ⓜ) to drag the point to a new position; position it over a line (Ⓜ) to move the line.

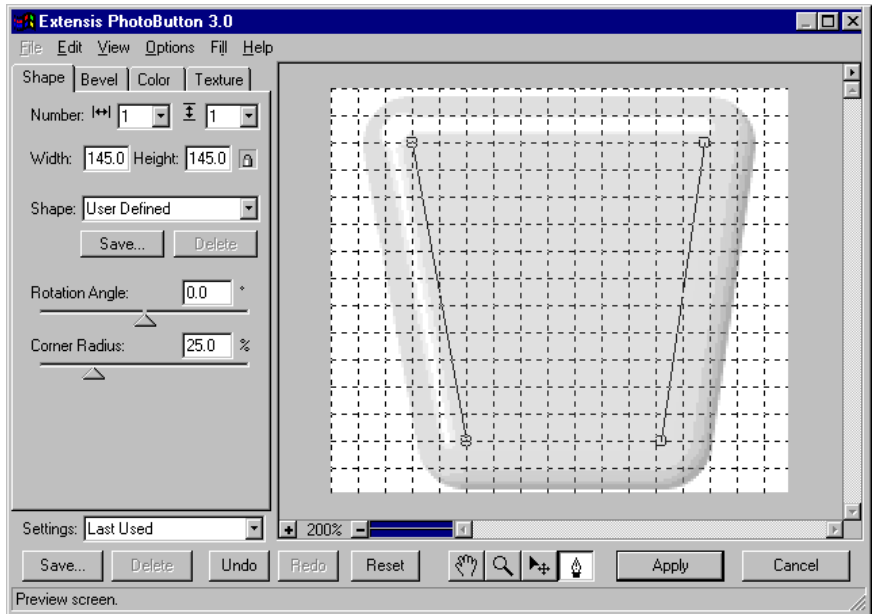

When you make any change to a shape, the Shape pop-up changes to “User Defined.”

3. To add points to the design, position the Pen tool over a line, then Option-click [Alt-click] (Ⓜ) to create the new point. To delete a point, Option-click [Alt-click] (Ⓜ) over an existing point.
4. Add or delete anchor points, and drag the points and lines to create just the shape you want.

### Things to Know about Custom Shapes:

- Once a custom shape has been saved it behaves like any other pre-defined shape, and can be selected from the Shapes pop-up.
- To create a custom shape you must start with an existing shape, then add, move, or delete points as necessary to create the new shape.
- Shapes can only be made up of one path. You cannot create gaps or holes in the design.
- Each shape is limited to 64 lines/65 points (64 sides).
- Paths cannot be imported.
- Saving a shape saves only the shape anchor points and paths. Other effect values are saved from the Settings dialog.

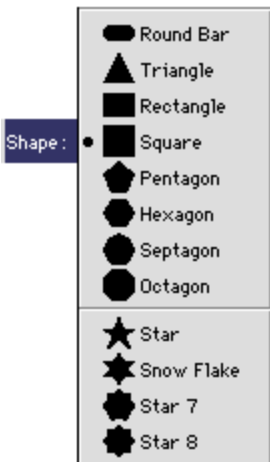

### To save a Custom Button Shape:

1. Create a new button shape as described on *page 60*.
2. Click the “Save” button below the Shape pop-up menu.

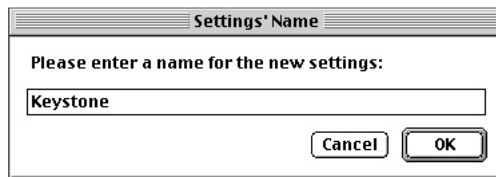

Only the button *shape* will be saved. To save other shape attributes, such as rotation angle and corner radius, create a button “Settings” (see *page 36*).

3. The new shape will be saved and added to the Shape pop-up menu.

### To use a Custom Button Shape:

*Note: You must have created and saved a custom button shape (as described above and on page 60) to have it available for future use.*

1. Select the Shape tab by clicking it.
2. Select a pre-defined custom shape from the Shape pop-up menu.

The selected shape replaces the current button shape in the Preview window.



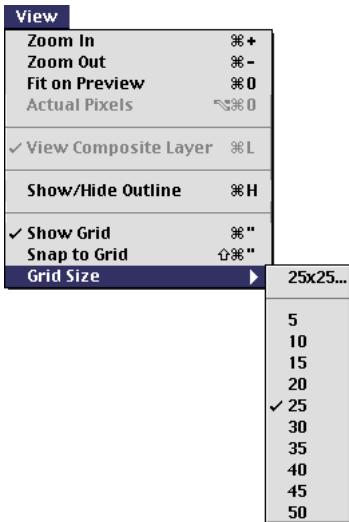

## The Shape Outline

You can toggle the shape outline on or off by selecting the “Show/Hide Outline” option from the View menu (View > Show/Hide Outline), or by pressing **Command-H [Alt+H]**.

## The Shape Grid

You can display a grid over the image in the Preview window to help you create and align your button shapes. You can choose a grid size between 5x5 and 50x50, and you can elect to have points and lines snap to the grid as you move them.

### To enable or disable the Grid:

1. Select “Show Grid” or “Hide Grid” from the View menu, or press **Command-'" [Ctrl+']**.

### To change Grid Size:

1. Select “Grid Size” from the view menu, then select the desired size from the Grid Size sub-menu.

## Creating Custom Button Bevels

The Bevel Shape Controls on the Bevel tab (see *page 65*) give you access to all the pre-defined button bevel shapes, and allow you to create, modify, and save shapes. You can select a bevel shape from the list and use it as-is, or modify it using the bevel editor on the Bevel Shape floating palette. You can show and hide the Bevel Shape palette by clicking the “Show/Hide Bevel Shape” button.



## Bevel Shape Editor

The Bevel Shape floating palette provides the means for creating and editing bevel shapes. You create bevels by adding points to the graph. You shape the bevels by dragging the points to different positions on the grid. Points are added by clicking on the graph where you want to add a point. To delete a point, select it and click “Delete.”

Each point controls one edge of a bevel. Moving a point along the Y axis controls the height of an individual bevel. Moving a point along the X axis controls the spacing between edges. When you move one point the others remain locked in place. The curve that joins the points will show peaks and valleys corresponding to the peaks and valleys of the bevels. Points affect the image from left to right, outermost bevel edge to innermost bevel edge.

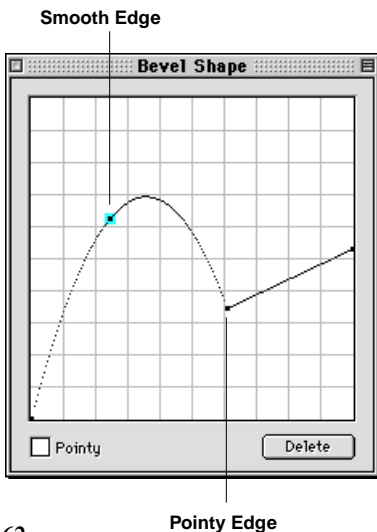

## Sample Bevel Shapes

Seven pre-defined bevel shapes are included on a pop-up menu on the button Bevel tab. You can use these bevel shapes as-is, or modify them to suit your needs, and you can save your custom bevel shapes for future use. Saving a bevel shape saves only the shape. To save the values of the other four bevel effects (Width, Height, Softness, and Inner Height), you must create a button "Settings" (page 36).

Three of the pre-defined bevel shapes are presented here to help you visualize the limitless possibilities.

- B** Half Pipe: Consists of five points. The first four points are Smooth, while the last (representing the innermost edge) is Pointy. This produces an overall smooth bevel, with a sharply defined inner edge. The edge rises from outside to center, then back down to the inner edge, creating a pipe-like look.
- A** Double: Consists of seven points. Similar to the Half Pipe, but with two rounded bevels. The outermost edge of each bevel is Pointy, as is the center point which separates the two bevels. The two inner points of each bevel are Smooth points, creating a rounded appearance. The overall effect is a double bevel with sharply defined edges with smooth transitions between them.
- C** Triangle: Consists of three points. All three are Pointy points, creating a sharp (chisel-like) transition between the outer, middle, and inner edges.

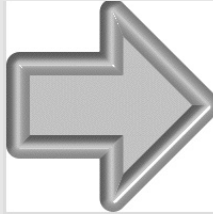

**A - Half Pipe**

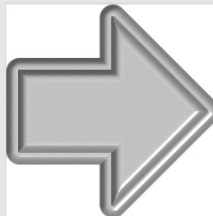
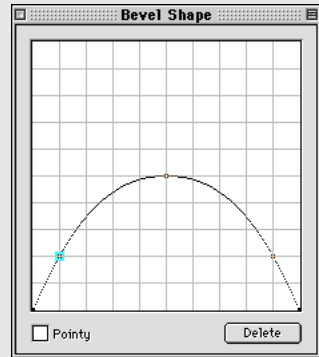

**B - Double**

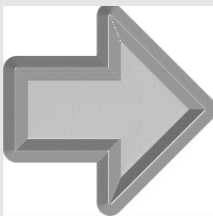
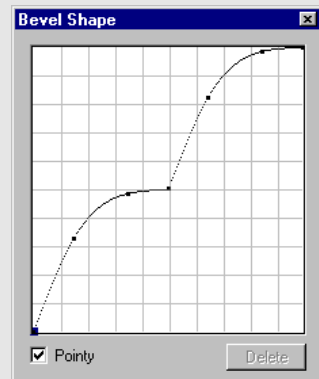

**C - Triangle**

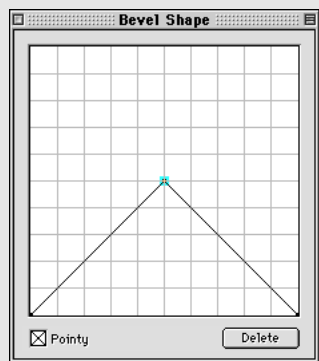

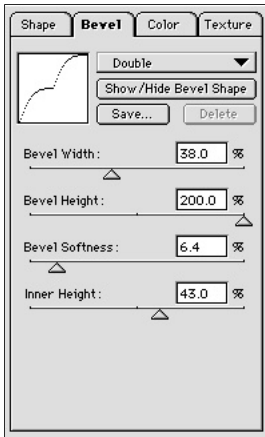

*Note: You can affect the width and height of all the bevels at once by using the Width and Height sliders. Other sliders allow you to change Bevel Softness and Inner Height. These attributes are not saved when you save the Bevel Shape. To save these other attributes you must create a button “Settings” (see page 36).*

Points can be used to create either a smooth (curving transition) edge, or a pointy (sharp transition) edge. Smooth edges are produced by default; sharp edges are produced when you click the Pointy box to enable it (an “x” indicates that the new point will create a sharp edge). You can change Smooth points to Pointy points and vice versa by selecting the point and enabling or disabling the Pointy option.

#### **To create or edit a Custom Bevel Shape:**

- 1. Select the Bevel tab by clicking it.**
- 2. Select a bevel shape from the pop-up menu.**

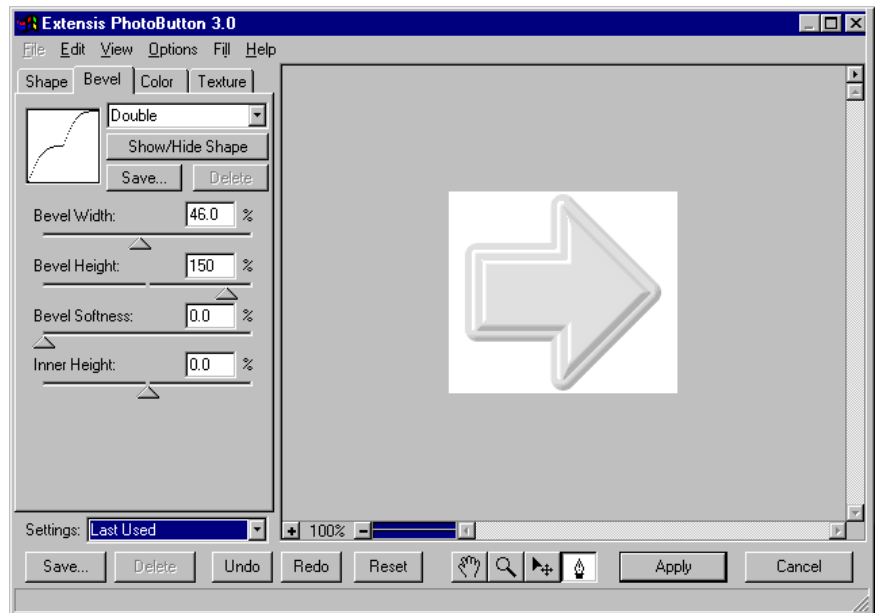

The selected shape parameters will be applied to the image in the Preview window, and the graph representing the currently selected shape will be displayed in the Bevel Shape thumbnail.



## Bevel Shape Controls

The button Bevel Shape Controls allow you to select, create, modify, and delete bevel shapes.

### Bevel Shape Controls

- A** Bevel Shapes Pop-up Menu: Provides access to all pre-defined and saved shapes. When a shape has been selected, any change to the displayed shape (editing it) will cause the "User Defined" name to be displayed.
- B** Bevel Shapes Thumbnail: Displays a thumbnail representation of the shape as shown on the BevelShape palette.
- C** Save: Allows you to name and save the current shape. When saved, the new shape appears on the Shapes Pop-up Menu (A). (This options saves only the bevel Shape. To save bevel style parameters, you must create a "Settings" (page 36).
- D** Delete: Deletes the selected Shape.
- E** Bevel Shape Editor: Clicking the button opens or closes the Bevel Shape editor palette. To use the editor, click to add a point to create a new edge. To change edge spacing and height drag the point to a new position on the grid. Select the point and click Smooth for a smooth bevel transition; click Pointy for a sharp transition.

### Bevel Shape Editor

- F** Bevel Shape points and curves: Displays a visual representation of the mathematical position, transition, and spacing of each bevel using a grid. Points correspond to bevel edges from left to right, outer to inner.
- G** Pointy edge selector: When enabled (X in the box), new points will have a Pointy, or sharp, edge. When not selected, new points will have a Smooth edge. To change an edge from Smooth to Pointy, select it's corresponding point and check this box. To change an edge from Pointy to Smooth, select it corresponding point and uncheck this box.
- H** Delete: Deletes the selected point.

### Bevel Shape Controls

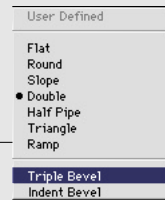
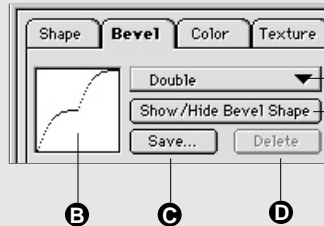

### Shape Applied to Button

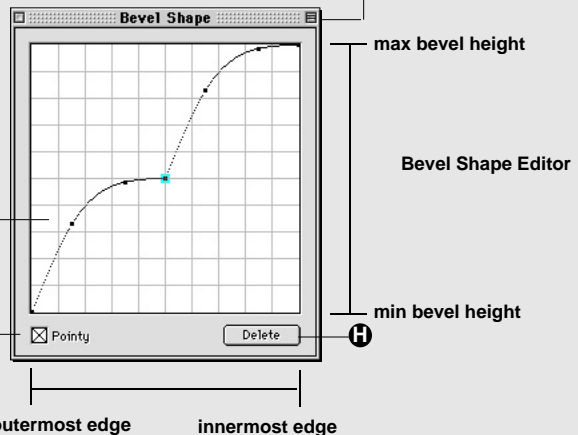
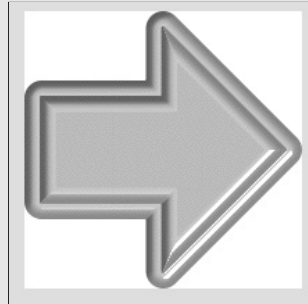

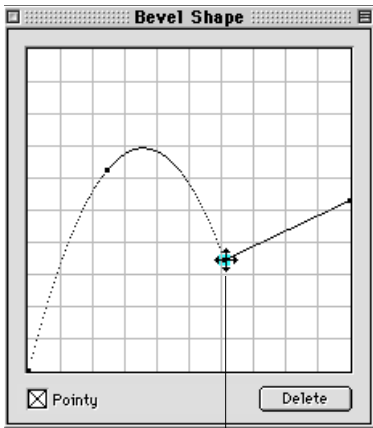

Click to place a new point. Click on an existing point to select it.

3. Open the Bevel Shape palette by clicking the “Show/Hide Bevel Shape” button.
4. Create bevels by clicking on the graph to create points. Each point represents a bevel edge on the image.  
Smooth points create smooth edge transitions. Pointy points created sharp, or “pointy” edge transitions. To an remove an edge from the image, select the corresponding point on the graph and click “Delete.”
5. Drag the points and/or connecting lines to different positions on the graph until you create the bevel design you are looking for.

You can follow your effect changes as you make them by watching the Preview window.

6. Add Style options such as highlighting and softness, or increase the bevel height and width for the whole image until you achieve the design you are looking for.

You can use the new shape and/or save it for future use.

#### To save a Custom Bevel Shape:

1. Click the “Save” button under the “Show/Hide Bevel Shape” button.
2. Enter a name for the Shape, then click “OK.”

Your custom Shape will be added to the bottom of the Bevel Shape pop-up menu.

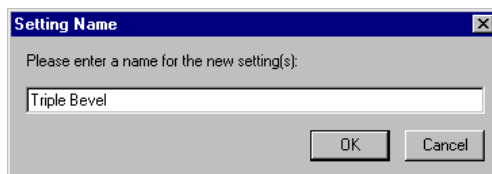
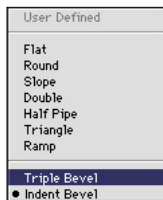

*Note: To save other bevel attributes, such as Bevel Height, Bevel Width, Bevel Softness, and Inner Height, you will need to create a Settings (see page 36).*

## Coloring Buttons

---

*Note: Options that affect color are discussed in “Creating Color Effects using Surface Property Controls” on page 72.*

Color can be applied separately or simultaneously to the two button parts (Inner and Bevel) and the button Outer area.

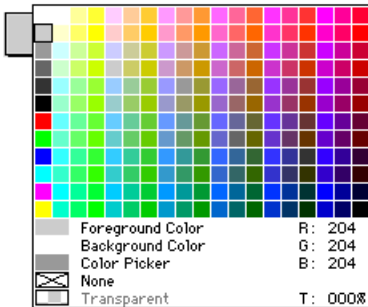

**Paint Color pop-up:** Provides access to the PhotoButton Color Palette, the current Photoshop Foreground and Background colors, and the Color Picker. Color values are shown on the right side of the palette, reflecting both the current Color Mode (RGB, CMYK, etc) and the color values of the highlighted color.

*Note: In RGB mode, the Color pop-up displays all and only “web-safe” colors. This does not mean that the final result color will be web-safe, since button colors may be blended and/or faded to the background.*

**None:** Remove or fill previously used color with No Color. Similar to resetting the color, but the None color swatch must be selected and applied as the Paint Color. Areas of the image colored “None” will show their original content.

**Transparent:** Transparent color. Value will always be 0% (opaque) except for the transparent color. This option becomes available when you are working on a layer with transparency. It can be used to “knock out” the background around the buttons.

*Note: Photoshop’s background layer does not include transparency. To add transparency to the Background layer: Before opening PhotoButton, double-click “Background” on the Photoshop Layer Palette (F7), then hit Return or Enter.*

*Note: When working on a normal (not Transparent) layer, for example the background layer, this feature allows the background image to “show through” a semi-opaque button, allowing you to create stunning button effects with textures, gradients, etc. Clicking Reset returns the buttons to their default condition, causing it to look like the buttons have disappeared. For instructions on how to make the button visible, refer to “Troubleshooting,” page 176.*

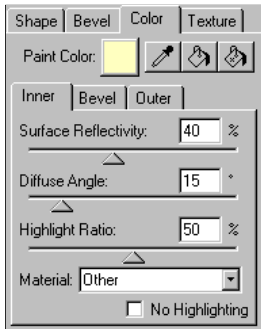

## Tip

Using the modifier keys and the Paint Color pop-up, you can select and fill all parts of all buttons without ever leaving the color pop-up. Simply keep the pop-up open and a modifier key down and watch the Preview. When you see the color (or effect) you want, release the modifier key. Keep the pop-up open and press the modifier for the remaining button parts. You can change colors this way until you achieve just the right effect.

This tip works with the Eye-dropper tool as well—with a modifier key pressed, drag the Eyedropper over the Preview and watch the button color change.

## To Color Button Parts Individually:

1. Select a color from the Paint Color pop-up, or use the Eyedropper to extract a color from the Preview.
2. Select the Paint Bucket tool, then click the button part you wish to color.

With the Fill Bucket (🪣) tool selected you can color any part of any button by clicking on it.

To remove a color, select the Remove Bucket (🪣) tool (the bucket with an “x” on it), then click the button part.

## To Color a Button Part for all Buttons Simultaneously:

1. Click and hold the Paint Color Pop-up.
2. Press and hold the modifier key for the button part you wish to color.

Modifier keys:

**Inner:** Shift

**Bevel:** Option [Alt]

**Outer:** Command [Ctrl]

3. When you see the color you want to apply to the button part, release the modifier key and/or the pop-up.

— *or* —

1. Select the Eyedropper tool, then drag it over the Preview.

2. Follow steps 2 and 3 above.

— *or* —

1. Select the desired color using either the Paint Color pop-up or the Eyedropper.
2. Select the Paint Bucket tool.
3. Hold down the Option [Ctrl] and click the Paint Bucket tool on the button part you wish to color.

The selected color will be applied to the selected button part of all the buttons.

## Creating Color Effects Using Surface Property Controls

Once you have selected and applied a Paint Color to the selected button part, you can adjust or apply effects to the color using the Surface Property Controls in the Inner, Bevel, and Outer Color tabs. Surface Property Controls include: Surface Reflectivity, Diffuse Angle, and Highlight Ratio (*page 52*).

**Surface Reflectivity:** Controls the amount of light reflected or absorbed. 0% reflectivity yields a matte look, where all light is absorbed resulting in no reflection. 99% reflectivity yields a high gloss look, with maximum reflectivity.

**Diffuse Angle:** Controls the degree to which light is diffused over the surface. 1% diffusion yields a focused, spotlight effect, while 90% diffusion yields a diffused, washed-out effect.

**Highlight Ratio:** Controls the amount of light striking the selected button part. 0% highlight yields no light. 100% yields maximum light.

**No Highlighting:** Disables the three Color Controls: Surface Reflectivity, Diffusion, and Highlight Ratio. The effect is as if all controls were set to minimum.

## Highlighting Color and Effects

The Highlighting Color Controls determine what Color will be used to highlight the button, and the Direction and Inclination of the light source for highlighting. Highlighting affects all the button parts unless you choose No Highlighting in the tab for any or all of the three button parts.

**Highlighting Color pop-up:** Used to select the color of the light being cast over the button parts. Similar to the button parts Color pop-up, but selects highlighting color. *Note: None and Transparency cannot be used for the Highlight Color.*

**Direction:** Controls the direction of the light source on a two-dimensional plane. Can be likened to shining a light on the image from north, south, east, or west, or any point in between.

**Inclination:** Controls the arc of the light source over the three dimensional plane. Can be likened to shining a light on the image from above, to the side, or any point in between. 90° Inclination indicates that the light source is directly over the image.

**Interactive Controls:** Use the directional model control knob to change Direction and Inclination simultaneously. When the knob is in the center, inclination is 90°. 0° inclination means the light source is in the same plane as the buttons.

### Highlighting Color Controls

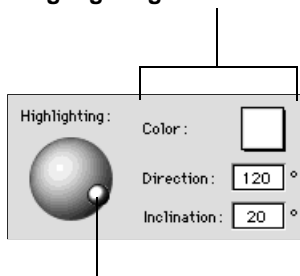

Control Knob for Interactive Control

## Adding Textures and Bump Maps

Texture file applied as a Texture



Same file applied as a Bump Map

You can use existing JPEG (.jpg) files (such as those created in PhotoTexture) and even alpha channels to add textures and bump maps to your buttons.

**Textures:** Textures are two-dimensional images that you can use to create a background for the button inner, bevel, and/or outer areas. Highlighting does not affect textures.

**Bump Maps:** Bump maps can be created from the same two-dimensional images (JPEGs and alpha channels) that you can use to add texture to the button. But bump maps use only the luminosity values of the image, creating raised bumps or depressed areas based on bump map blur and height, and button highlighting. Bump maps can be applied to the inner, bevel, and/or outer button areas.

You can apply a texture or bump map to selected sections of a button by clicking it with the appropriate Texture Bucket (🪣) or Bump Map Bucket (🪣). To apply a Texture or Bump Map to all parts of all buttons at once, click the appropriate “Fill All” button on the Texture tab.

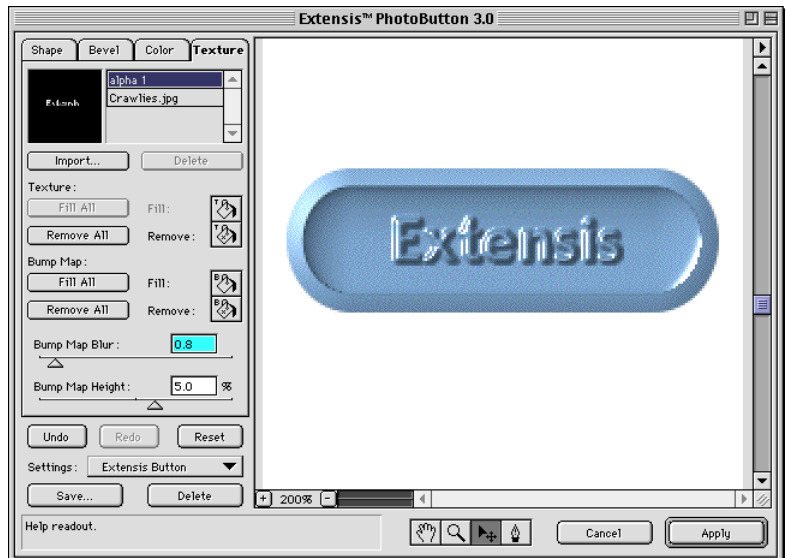

To remove a texture or bump map from individual button parts, click the area with the appropriate Remove Bucket (🪣) (“x” displayed on the bucket, “T” or “B” in the upper left of the icon). You can remove all button textures or bump maps by clicking the appropriate “Remove All” button.

# PhotoGroove

*Note: Many controls, options, and commands are common to all the PhotoEffects plug-ins. For detailed information on those elements, refer to “The PhotoEffects Plug-ins” starting on page 33.*

## Tip

For a listing of keyboard shortcuts, see Appendix A, page 174.

Grooves and bevels give the selected parts of an image a raised or lowered appearance by applying highlights to the inside and outside edges. With PhotoGroove, you have infinite control over the number, shape, and spacing of grooved edges using an interactive shaping grid. You can create complex compound grooves simply by adding or deleting points on the curve, then change the width and spacing by dragging the curve to any point on the graph, and you can save your shapes for later use. PhotoGroove also provides you with a thumbnail preview of the shaping graph for the currently selected shape.

All groove options, including shaping, bevel width, edge feathering, softness, highlights, and light direction respond in real-time, and you can optionally view composite layers to see just how your effects will look with other picture elements.

## The PhotoGroove Dialog Box

- A** Preview Window
- B** Shape Controls: Control shape and spacing of individual grooves and bevels using an interactive shaping palette (see page 76).
- C** Width: Adjusts width for all edges at once.
- D** Height: Adjusts depth for all edges at once.
- D** Softness: Adjusts bevel softness, or the transition between light and dark.
- F** Material: Apply preset surface property parameters like Chrome, Heavy Metal, Metal, Plastic, Rubber, and Matte.
- G** Highlights Pop-up Color Palette: Set the inner and outer bevel highlight color. Color picked with the eyedropper is displayed here.
- H** Light Direction Field and Indicator: Adjusts the direction and inclination of the light source. Indicates direction and inclination in °.
- I** Highlight Inner/Outer: Determines whether selected highlight color will affect Inner (the bevel and anything inside it), Outer (the entire area outside the selection), both or neither.
- J** Settings controls: Save, Select, and Delete effect Settings (see page 36).
- K** Help Box: Displays a description of each tool or option as the mouse passes over it.

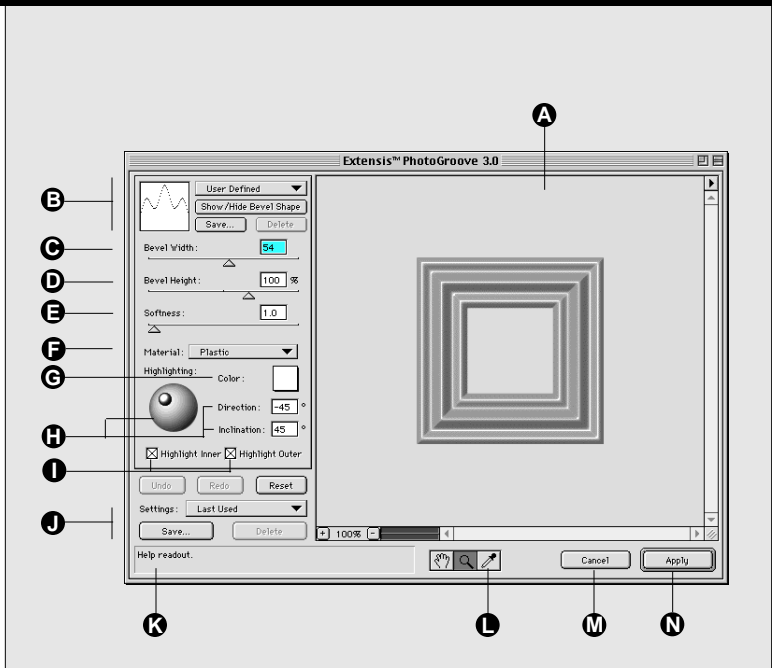

- L** Highlight Eyedropper: Extracts a highlight color from the preview.
- M** Cancel: Closes the dialog box without making changes to the image. You can also Cancel by pressing **Command-“.”** (period) **[Alt+F4]**.
- N** Apply: Adds your selected effects to the image and closes the dialog box. You can also Apply the effect by pressing Return or Enter.

## Shape Controls

The Shape Controls allow you to select, create, modify, and delete bevel shapes.

### Shape Controls

- A** Shapes Pop-up Menu: Provides access to all pre-defined and saved shapes. When a shape has been selected, any change to the displayed shape (editing it) will cause the "User Defined" name to be displayed.
- B** Shapes Thumbnail: Displays a thumbnail representation of the shape as shown on the BevelShape palette.
- C** Save: Allows you to name and save the current shape. When saved, the new shape appears on the Shapes Pop-up Menu (A). (This options saves only the bevel Shape. To save bevel style parameters, you must create a "Settings" (page 36).
- D** Delete: Deletes the selected Shape.
- E** Bevel Shape Editor: Clicking the button opens or closes the Bevel Shape editor palette. To use the editor, click to add a point to create a new edge. To change edge spacing and height drag the point to a new position on the grid. Select the point and click Smooth for a smooth bevel transition; click Pointy for a sharp transition.

### Bevel Shape Editor

- F** Bevel Shape points and curves: Displays a visual representation of the mathematical position, transition, and spacing of each bevel using a grid. Points correspond to bevel edges from left to right, outer to inner.
- G** Pointy edge selector: When enabled (X in the box), new points will have a Pointy, or sharp, edge. When not selected, new points will have a Smooth edge. To change an edge from Smooth to Pointy, select it's corresponding point and check this box. To change an edge from Pointy to Smooth, select it corresponding point and uncheck this box.
- H** Delete: Deletes the selected point.

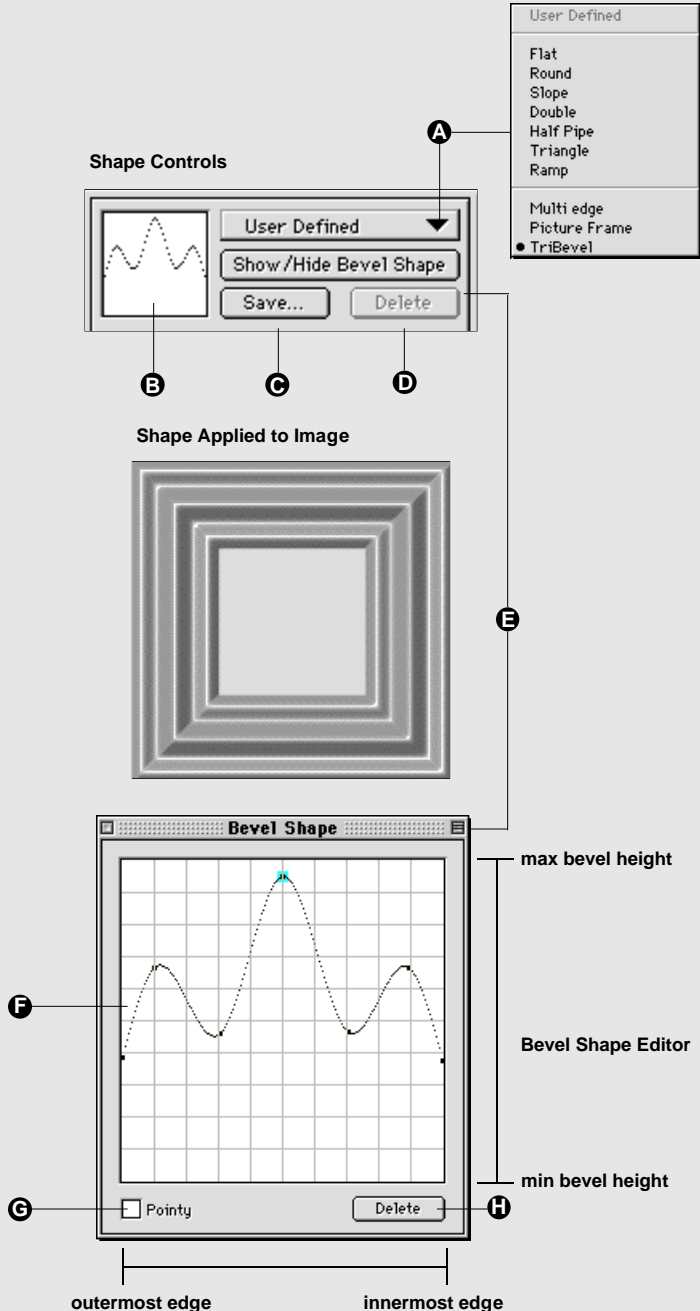



## Shape Controls

The bevel Shape Controls (see **(B)** on *page 75*, and the figure on *page 76*) give you access to all the pre-defined shapes, and allow you to create, modify, and save bevel shapes. You can select a shape from the list and use it as-is, or modify it using the bevel editor on the Bevel Shape floating palette. You can show and hide the Bevel Shape palette by clicking the “Show/Hide Bevel Shape” button.

### Bevel Shape Editor

The Bevel Shape floating palette provides the means for creating and editing bevel shapes. You create bevels by adding points to the graph. You shape the bevels by dragging the points to different positions on the grid. Points are added by clicking on the graph where you want to add a point. To delete a point, select it and click “Delete.”

Each point controls one edge of a bevel. Moving a point along the Y axis controls the height of an individual bevel. Moving a point along the X axis controls the spacing between edges. When you move one point the others remain locked in place. The curve that joins the points will show peaks and valleys corresponding to the peaks and valleys of the bevels. Points affect the image from left to right, outermost bevel edge to innermost bevel edge.

*Note: You can affect the width and height of all the bevels at once by using the Width and Height sliders ((C) and (D) on page 75).*

Points can be used to create either a smooth (curving transition) edge, or a pointy (sharp transition) edge. Smooth edges are produced by default; sharp edges are produced when you click the Pointy box to enable it (an “x” indicates that the new point will create a sharp edge). You can change Smooth points to Pointy points and vice versa by selecting the point and enabling or disabling the Pointy option.

### Selecting and Saving Bevel Shapes

When a shape has been selected, any change to the displayed shape (that is, once you start editing it) causes the “User Defined” shape name to be displayed. The newly created shape can then be saved with a different name, and selected from the Shapes pop-up.

*Note: Saving a bevel shape using the Save button in the Shape Controls area does not also save bevel style parameters like softness and highlighting. To save styles, create a Settings using the Settings controls near the bottom of the palette (page 36.)*

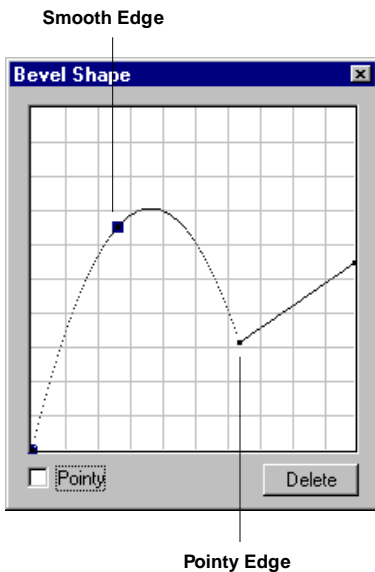

## Sample Shapes

Seven pre-defined shapes are included with PhotoGroove that you can use as-is, or modify to suit your needs. (You can also create your own shapes from "scratch.") Three of the pre-defined shapes are presented here to help you visualize the limitless possibilities.

- A Ramp:** Consists of two points. Both the outer edge and inner edge points are smooth, creating a smooth transition on both edges. The bevel also progresses upward from the outer to the inner, giving a raised center, or plateau, appearance.
- B Half Pipe:** Consists of five points. The first four points are Smooth, while the last (representing the innermost edge) is Pointy. This produces an overall smooth bevel, with a sharply defined inner edge. The edge rises from outside to center, then back down to the inner edge, creating a pipe-like look.
- C Triangle:** Consists of three points. All three are Pointy points, creating a sharp (chisel-like) transition between the outer, middle, and inner edges.

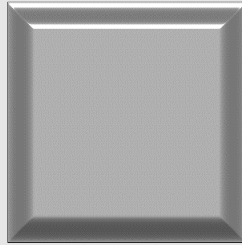

**A - Ramp**

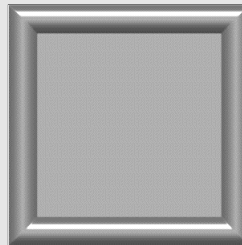
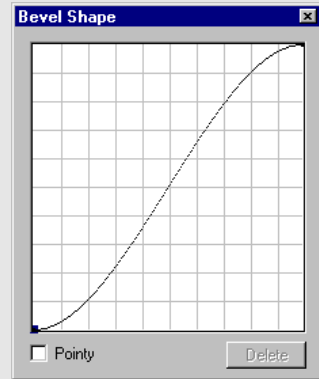

**B - Half Pipe**

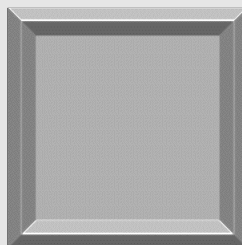
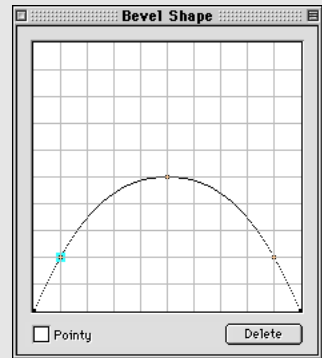

**C - Triangle**

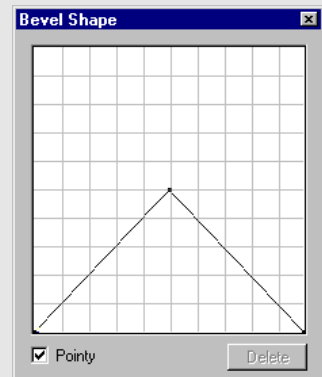

### To create or edit custom bevels using PhotoGroove:

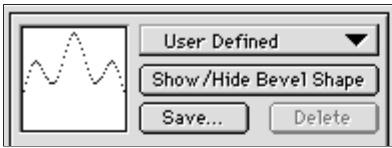

1. Select a bevel shape from the pop-up menu in the top left corner of the PhotoGroove window, or do nothing to work with the Last Used settings that are automatically applied to the image.

The selected shape parameters will be applied to the image in the Preview window, and the graph representing the currently selected shape will be displayed in the Bevel Shape thumbnail.

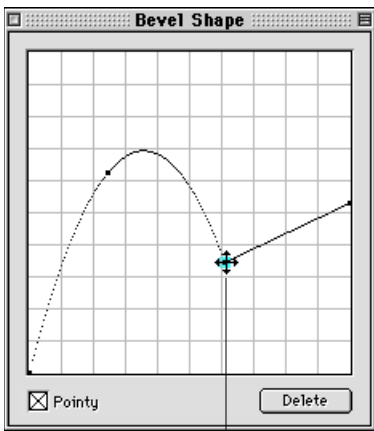

Click to place a new point. Click on an existing point to select it.

2. Open the Bevel Shape palette by clicking the “Show/Hide Bevel Shape” button.
3. Create bevels by clicking on the graph to create points. Each point represents a bevel edge on the image.

Smooth points create smooth edge transitions. Pointy points created sharp, or “pointy” edge transitions. To an remove an edge from the image, select the corresponding point on the graph and click “Delete.”

3. Drag the points and/or connecting lines to different positions on the graph until you create the bevel design you are looking for.

You can follow your effect changes as you make them by watching the Preview window.

4. Add Style options such as highlighting and softness, or increase the bevel height and width for the whole image until you achieve the design you are looking for.
5. Click “Apply” to apply the effect to your image.

### To Save a Shape:

1. Click the “Save” button under the “Show/Hide Bevel Shape” button.
2. Enter a name for the Shape, then click “OK.”

Your custom Shape will be added to the pop-up menu.

*Note: To save style settings along with the shape, you will need to create a “Settings” (see page 36).*

## Bevel Style Controls

---

You can apply style parameters to your bevels (style options are applied to all bevels at once), such as edge softness and highlighting. Two other options which are considered style characteristics are Width and Height [(C) and (D), *page 75*]. These affect all the bevels, unlike the size and spacing controls on the Bevel Shape editor that you use to affect each bevel individually.

### Width, Height, and Softness

Adjust the Softness control to soften all the beveled edges equally. Adjust the Width and Height controls to adjust the width and/or height of all bevels equally.

### Highlighting Color and Effects

The Highlighting Controls ((G), (H), and (I), *page 75*) determine what Color will be used to highlight the bevels, and the Direction and Inclination of the light source for highlighting. Highlighting affects all the bevels. You can elect to highlight just the inner edges, just the outer edges, or turn off both options to have no highlighting.

**Highlighting Color pop-up:** Selects the color of the light being cast over the bevels. Highlighting color extracted from the image using the Eyedropper tool is displayed here.

**Direction:** Controls the direction of the light source on a two-dimensional plane. Can be likened to shining a light on the image from north, south, east, or west, or any point in between.

**Inclination:** Controls the arc of the light source over the three dimensional plane. Can be likened to shining a light on the image from above, to the side, or any point in between. 90° Inclination indicates that the light source is directly over the image.

**Interactive Controls:** Use the directional model control knob to change Direction and Inclination simultaneously. When the knob is in the center, inclination is 90°. 0° inclination means the light source is in the same plane as the bevels.

**Highlight Inner/Outer:** Click to select inner, outer, both, or no highlighting. An “x” in the box indicates that highlighting will be applied.

### Highlighting Color Controls

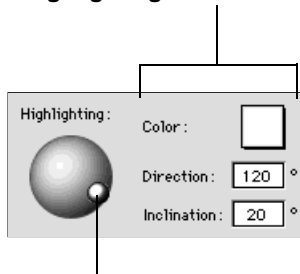

Control Knob for Interactive Control

# PhotoCastShadow

*Note: Many controls, options, and commands are common to all the PhotoEffects plug-ins. For detailed information on those elements, refer to “The PhotoEffects Plug-ins” starting on page 33.*

## Tip

For a listing of keyboard shortcuts, refer to *Appendix A, page 174*.

PhotoCastShadow is the fastest, most robust shadow generator ever developed. Instantly create professional multiple cast shadows and drop shadows. Grab a corner, edge, or center of the shadow’s wireframe to interactively rotate, stretch, and skew the shadow to any perspective, and place it anywhere on the image. Easily adjust the shadow’s perspective blur to show realistic dimension—without purchasing and learning a 3-D application.

Add shadows, show or hide them, and see the results of all visible shadows on the composite image interactively, as you create or modify each one. Use Invert Shadow to create useful cutouts and other effects. Select Shadow Only to isolate the whole shadow—not just the shadow outline—on its own layer. And as with all PhotoEffects, you can undo and redo effects multiple times, and save effects settings for future use.

## The PhotoCastShadow Dialog box

- A** Preview Window
- B** Shadows List: Lists all the shadows created for this image. Eye icon indicates that a shadow is visible. Only shadows displaying the eye icon will be applied to the image when the Apply button is clicked.
- C** Add/Delete Shadow: Allows you to add, rename, or delete shadows.
- D** Style and Shape Tabs: Provides interactive controls for adjusting shadow attributes—see page 78.
- E** Settings Controls: Select, Save, and Delete effect settings. See page 36.
- F** Help Box: Displays a description of each tool or option as the mouse passes over it.
- G** Adjustment tool: Allows you to shrink, stretch, rotate, position, and skew the selected shadow.
- H** Eyedropper: Allows you to specify a color for the selected shadow by selecting it from the preview.
- I** Cancel: Closes the dialog box without making changes to the image. Also Cancel by pressing **Command-“.” [Alt+F4]**.
- J** Apply: Adds your selected effects to the image and closes the dialog box. You can also Apply the effect by pressing Return or Enter.

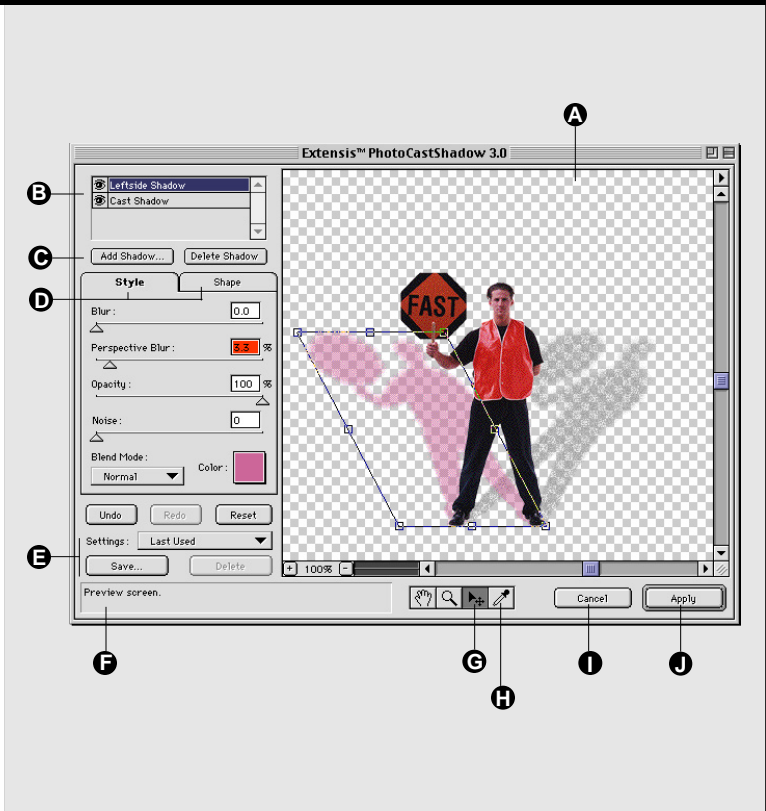

## Shadow Style and Shape tabs

### Style Options

- A** Blur: Controls amount of shadow blur, in pixels. This blur is a constant, providing the same blur value everywhere around the image.
- B** Perspective Blur: Controls shadow blur, in pixels. Blur changes depending on how far the shadow is from its corresponding spot on the image. Creates a more realistic 3-D shadow.
- C** Opacity: Controls translucency of the shadow, as a percentage. 0% opacity is completely transparent; 100% opacity is completely opaque.
- D** Noise: Controls amount of noise applied to the shadow. This blur is value is constant, providing the same blur value everywhere around the image.
- E** Blend Mode: Normal, Multiply, Screen, Darken, Lighten, Difference. Effect is applied only on the target layer.
- F** Color palette popup: Sets the shadow color. Color picked with the eyedropper is displayed here.

### Shape Options

- G** X Offset: How far the shadow is offset from the image in the horizontal plane, in pixels.
- H** Direction: Angle at which the shadow slants away from the image, in degrees.
- I** Reset Shadow Shape: Click to restore the selected shadow to the last-saved settings.
- J** Invert Selection: Inverts the effect, applying the shadow inside the selection rather than outside it.
- K** Create Shadow only: Moves the shadow in front of the selection in the Preview window. Keeps the shadow and deletes the image on selecting Apply (see page 83 for more details).
- L** Y Offset: How far the shadow is offset from the image in the vertical plane, in pixels.
- M** Length: Length of shadow, as a percentage of image size.
- N** Rotation Angle: Shadow rotation, in degrees.

### Style

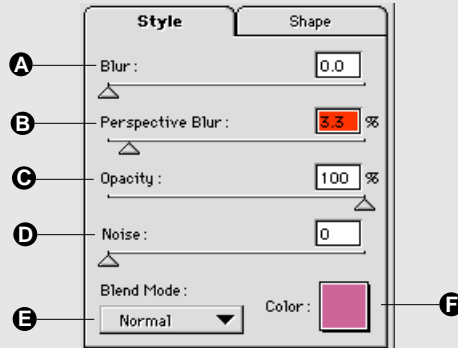

### Shape

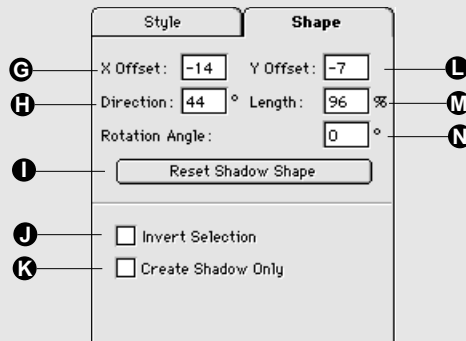

## Getting Started with PhotoCastShadow

---

### Inside (move)

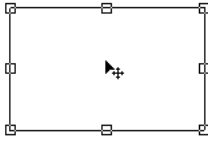

### Outside (rotate)

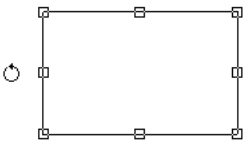

### Sides (Distort left/right, up/down)

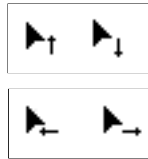
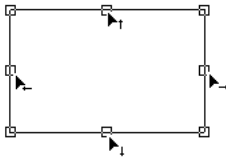

Sides



Inside



Outside

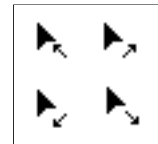

Corners

### Corners (Distort in/out)

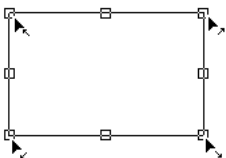

### Dual direction distort (side handle movement shown)

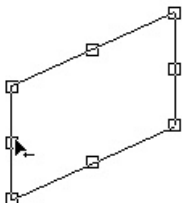

### The Shadow Frame

PhotoCastShadow provides you with an interactive wireframe that bounds the shadow on all sides, so that you can quickly and easily manipulate the size, shape, and placement of the shadow. As with all of the PhotoEffects plug-ins, when you open PhotoCastShadow, the shadow applied to the selected image will be what was automatically saved in the Setting “Last Used.”

The shadow frame has 8 handles, or hot spots, one on each side and one on each corner, that allow you to shrink, stretch, pull, and skew the shadow into various shapes. Two other hot spots, one inside the box and the other outside the box, allow you to position the shadow—either offsetting it from the image slightly, or placing it anywhere on the canvas—and to rotate the shadow a full 360°.

You will see the shadow frame whenever you have the

Adjustment tool selected and positioned inside the Preview window. As you pass the Adjustment tool over the 10 hot spots, the tool will change shape to indicate the type of movement that will be applied when you click and drag from that spot.

The side handles (top, bottom, left, right) can drag the image from their respective side of the shadow in any direction. The corner handles can drag the image from their respective corner in any direction. The inside and outside pointers will drag the entire shadow and frame.

## Creating Multiple Shadows

Each shadow appears on the Shadows List, even if you only one shadow has been created. Double-click a name on the list to change it.

- A** Show/Hide Shadow Indicator: Eye icon indicates that the shadow is visible in the Preview window, and will be applied to the image when the effect is applied.
- B** Selected Shadow: The currently selected shadow is highlighted on the list. Effect options (position, style, shape, color) are applied to the selected shadow. In the Preview window, click a shadow to select it.
- C** Shadow List: Lists all the shadows available for the current editing session. Shadows on the list are saved in the shadow Settings, when the Settings is saved.
- D** Add Shadow: Click to add and name the new shadow.
- E** Delete Shadow: Click to delete the selected shadow.

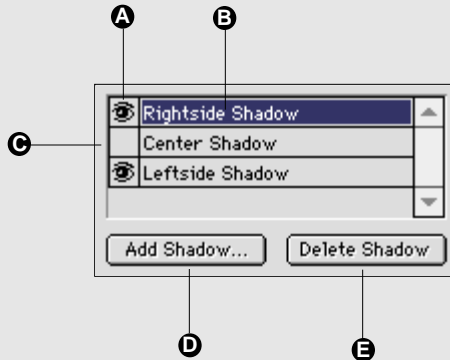

### Tip

To “start over” when your selected shadow has been skewed beyond usefulness, click Reset Selected Shadow.

To maintain Color and Blur settings while Resetting all other effect parameters, press **Option [ALT]** when you click Reset.

### Shadow Style Options (Style Tab)

Other shadow effects, such as Blur, Perspective Blur, and Opacity, can be adjusted with the interactive sliders or entered as absolute values.

### Blurs, Blends, Noise and Color Controls (Style Tab)

The Blur, Opacity, Noise, Blend, and Color Controls behave exactly as they would if applied directly in Photoshop, except that the PhotoCastShadow blend modes only blend the effect pixel with the target layer pixels (not affecting any underlying layers).

With Perspective Blur, you have the additional advantage of having a blur that decreases the closer it is to its corresponding spot on the image. This makes the shadow look more realistic, allowing you to create truly professional 3-D effects—in a fraction of the time, and without the overhead of complex 3-D graphics software.

The Color pop-up allows you to interactively see how your shadow will look as you move the pointer back and forth over the colors in the palette. Dragging the Eyedropper over any colored area in the Preview window allows you to interactively see the effect of changing your shadow color using a color from the Preview window.



## Tip

To constrain Adjustment tool to Side movement during a resize operation, press **Command [CTRL]** while dragging.

To constrain the Adjustment tool to Center movement, press **Option [Alt]** dragging.

## Shadow Position and Shape Values (Shape Tab)

The two shadow position controls and most of the shadow shaping controls can be entered in absolute values using the parameter entry boxes. These include: X and Y Offset, Direction, Length, and Rotation.



Using these absolute values, a shadow exactly the same size, shape, and location as the image would have X and Y Offsets of zero pixels, a Length of 100%, a Direction of 0%, and a Rotation of 0°, and would be completely hidden by the image (unless a Blur has been added, in which case the shadow would “peek” around the edge of the selection like a glow.)

The one shaping control that does not have an equivalent absolute value is Corner distortion. To distort from a corner you must use the Pointer tool to drag from the corner.

## Position Controls

The two position controls in PhotoCastShadow, Move and Rotate, control the position of the shadow in the X/Y plane of the canvas, and its rotation. The Position Controls, unlike the Shape Controls, operate on the full shadow, allowing you to move it anywhere on the canvas, or rotate around its centerpoint a full 360 degrees.

### To Position the Shadow:

1. Select the Adjustment tool (  ).
2. Place the tool inside the shadow frame: the pointer should look like the Adjustment tool (  ).
3. Click and drag the shadow to the desired position, then release.

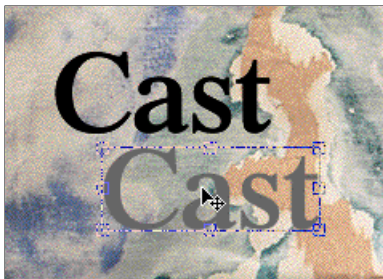

— or —

1. Enter the desired position using the X and Y coordinate boxes.



X Offset:  Y Offset:

### To Rotate the Shadow:

1. Select the Adjustment tool (  ).
2. Place the tool outside of the shadow frame: the pointer should look like a circular arrow (  ).
3. Click and drag the shadow to the desired position, then release.

— or —

1. Enter the desired rotation using the Rotation Angle attribute box.





Rotation Angle:  °

## Shape Controls

The 8 handles, or hot spots, along the border of the shadow frame constitute the Shape Controls. The Shape Controls operate together, giving you full freedom to reshape the shadow in nearly any way imaginable. Parameters affected are the X Offset, Y Offset, Direction, and Length.

### To Distort the Shadow Shape:

1. Select the Adjustment tool ().
2. Place the tool on any handle around the perimeter of the shadow frame: the pointer should look like an arrow with a directional pointer ().
3. Click and drag the shadow to the desired position.

— or —

1. Enter the desired shape parameters in the shape parameter boxes on the Shape tab.

*Note: The only size parameter you cannot change by entering a value in a parameter box is Corner distortion. To distort from a corner, you must use the Adjustment tool to drag from a corner.*



Length:  %



Direction:  °



Direction:  °



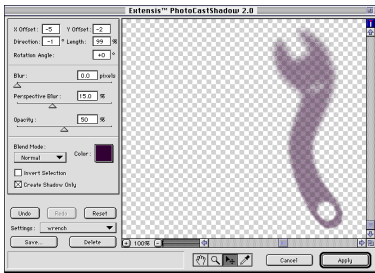

### Create Shadow Only (Shape Tab)

Allows you to separate all visible shadows from the image permanently, and provides you with a full shadow image, not just the outline. When you select this option the shadow(s) will move in front of the image in the Preview window, and the image itself will be discarded when the effects are applied.

*Important: If you wish to keep a copy of the original image layer after selecting and applying Create Shadow Only, you **must** create a copy of the layer before opening PhotoCastShadow.*



### Invert Selection (Shape Tab)

Allows you to invert the shadow color and move the shadow from outside the image to inside it, creating a variety of interesting effects, including cutouts.

### Shadow Preset Settings

PhotoCastShadow includes several pre-configured default shadows that you can select from the Settings menu. You may want to use these shadows “as is,” or as a starting point for more creative and complex shadow effects.

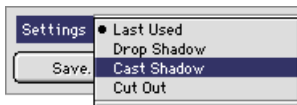

Default shadow settings include: Last Used, Drop Shadow, Cast Shadow, and Cutout. Last Used is updated each time your effects are applied to the image, and will be automatically reapplied each time you open PhotoCastShadow. To change this setting, either click Reset to eliminate all shadow effects (start from scratch), select an effect setting from the pop-up menu, enter values in the attribute boxes, or just begin manipulating the shadow frame.

Only the shadow(s) visible in the Preview window (eye icon being displayed) are saved when you create shadow Settings.

For more detailed information on creating, selecting, saving, and using Settings, refer to *page 36*.

# PhotoBevel

*Note: Many controls, options, and commands are common to all the PhotoEffects plug-ins. For detailed information on those elements, refer to “The PhotoEffects Plug-ins” starting on page 33.*

## Tip

For a listing of keyboard short-cuts, see *Appendix A, page 174*.

With PhotoBevel, you have point and click control over four different bevel types that can be applied to an image or floating selection (such as text): Flat, Round, Slope, and Double. You can apply a different bevel to the inside and/or outside edge of the selection area, control bevel edge tolerance, and apply different colors to the highlight (affecting the inside edges) and the shadow (which affects the outside edges).

All bevel options, including edge feathering, softness, highlights, shadow intensity, and light direction respond in real-time, and you can optionally view composite layers to see just how your effects will look with other picture elements.

## The PhotoBevel Dialog Box

### A Preview Window

**B** Bevel Type: Controls Inner and Outer Bevel options. Outer is only active if you've selected less than the entire image.

Bevel Shape: Controls bevel shape (Flat, Round, Slope, or Double).

**C** Edge Tolerance: Refers to feathered and implicit selections. Allows you to control which pixels PhotoBevel considers the edge. Maximum: All feathered pixels are used when defining the bevel area; Minimum: No feathered pixels used; Medium: Half of feathered pixels used.

**D** Width: Determines bevel width. Softness: Similar to a blur; it softens the transition points between light and dark.

**E** Balance: Adjusts balance between the Highlight and the Shadow of the bevel.

**F** Highlight and Shadow Intensity: Control the strength of bevel highlights and shadows.

**G** Light Direction Field and Indicator: Adjusts the direction of the light source and indicates direction in °.

**H** Highlight and Shadows Pop-up Color Palettes: Sets the bevel highlight and shadow colors. Colors picked with the eyedroppers are displayed here.

**I** Settings controls: Save, Select, and Delete effect Settings.



**J** Help Box: Displays a description of each tool or option as the mouse passes over it.

**K** Highlight Eyedropper: Extracts a highlight color from the preview.

**L** Shadow Eyedropper: Extracts a shadow color from the preview.

**M** Cancel: Closes the dialog box without making changes to the image. You can also Cancel by pressing Command+“.” (Macintosh) or ALT+F4 (Windows).

**N** Apply: Adds your selected effects to the image and closes the dialog box. You can also Apply the effect by pressing Return or Enter.

# PhotoEmboss

*Note: Many controls, options, and commands are common to all the PhotoEffects plug-ins. For detailed information on those elements, refer to “The PhotoEffects Plug-ins” starting on page 33.*

## Tip

For a listing of keyboard shortcuts, refer to *Appendix A, page 174*.

PhotoEmboss works like no other embossing tool. Its unique controls and emboss styles give you the ability to create cutouts, embosses, reliefs, recesses, and many other special effects.

PhotoEmboss includes options for selecting the emboss type, along with the amount, of embossing. You control the contrast, softness, highlight and shadow of the embossing. In addition, you can position a directional light source and customize the color of the emboss highlight and shadow.

## The PhotoEmboss Dialog box

**A** Preview Window

**B** Emboss Type: Cutout, Raise, Edges, Blur.

**C** Cutout typically pushes in the selection area; **R**aise typically pushes out the selection area.

**E** Edges applies the highlight and shadow emboss colors around the inside and outside of the selection edge. This effect more dramatically defines the selection edge.

**B**lur creates an off focus, fuzzy emboss.

**C** Amount: Indicates Width of the emboss.

**D** Softness: Similar to a blur—softens the transition points between light and dark.

**C**ontrast: Controls the amount of difference between lightness and darkness of the emboss.

**E** Highlight and Shadow Intensity: Controls the strength of emboss highlights and shadow edges.

**F** Invert: Changes emboss effect 180°.

**G** Light Direction Field and Indicator: Adjusts the direction of the light source and Indicates direction in degrees.

**H** Highlight and Shadow Pop-up Color Palettes: Determine the bevel highlight and shadow colors. Colors picked with the eyedroppers are displayed here.

**I** Settings controls: Save, Select, and Delete effect Settings.

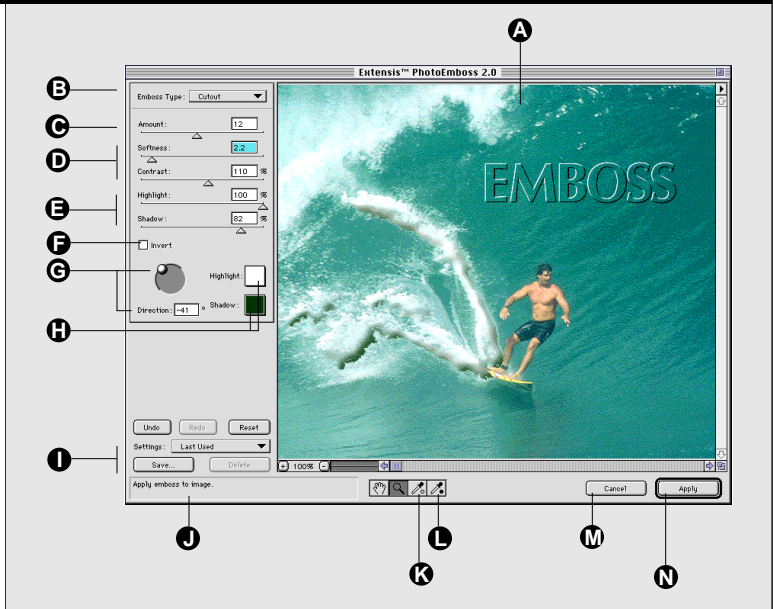

**J** Help Box: Displays a description of each tool or option as the mouse passes over it.

**K** Highlight Eyedropper: Extracts a highlight color from the preview.

**L** Shadow Eyedropper: Extracts a shadow color from the preview.

**M** Cancel: Closes the dialog box without making changes to the image. You can also Cancel by pressing Command+.", (Macintosh) or ALT+F4 (Windows).

**N** Apply: Adds your selected effects to the image and closes the dialog box. You can also Apply the effect by pressing Return or Enter.

# PhotoGlow

*Note: Many controls, options, and commands are common to all the PhotoEffects plug-ins. For detailed information on those elements, refer to “The PhotoEffects Plug-ins” starting on page 33.*

## Tip

For a listing of keyboard shortcuts, refer to *Appendix A, page 174*.

As an artist, imagine creating an image of a neon sign or a candle. You would typically add a glow effect around the outer edges of the neon sign and around the candle’s flame. PhotoGlow makes this process easy: apply a high radiance for a soft, subtle glow or a low radiance for an intense, hard, bright glow.

Apply a solid glow to the selected image or just to its edges. Determine how far the glow should extend, and control its radiance (glow diffusion). In addition, you can add a solid stroke around any selection. Change glow opacity (how much the glow will show through) to highlight an image containing light text on a light background: choose a glow color darker than the background, then increase the opacity of the letters’ glow to make them more visible against the light background.

## The PhotoGlow Dialog box

### A Preview Window

### B Glow Type: Edge, Solid

Edge applies the glow effect to the area defined by the selection edges.

Solid ignores enclosed selection areas within the selection. Fills in the hollow areas like the center of a selected “O.”

### C Stroke Shape: Square, Round

**D** Stroke Width: Controls the number of pixels from the image that the glow extends. A higher number indicates a fatter glow.

**E** Radiance: Indicates how abruptly the outer edge of the glow diffuses. A high number indicates higher diffusion.

**F** Opacity: Indicates the percentage of the glow that is allowed to be seen in the image.

**G** Blend Mode: Normal, Multiply, Screen, Darken, Lighten, Difference. These produce the same effect as when applied directly in Photoshop, except the effect is applied only on the target layer (see page 57 for more details).

**H** CreateGlow Only: Moves the glow in front of the selection in the Preview window. Keeps the glow and deletes the image on selecting Apply (see pages 49 and 57 for more details).

**I** Color Palette Pop-up: Sets the glow color. Color picked with the eyedropper is displayed here.

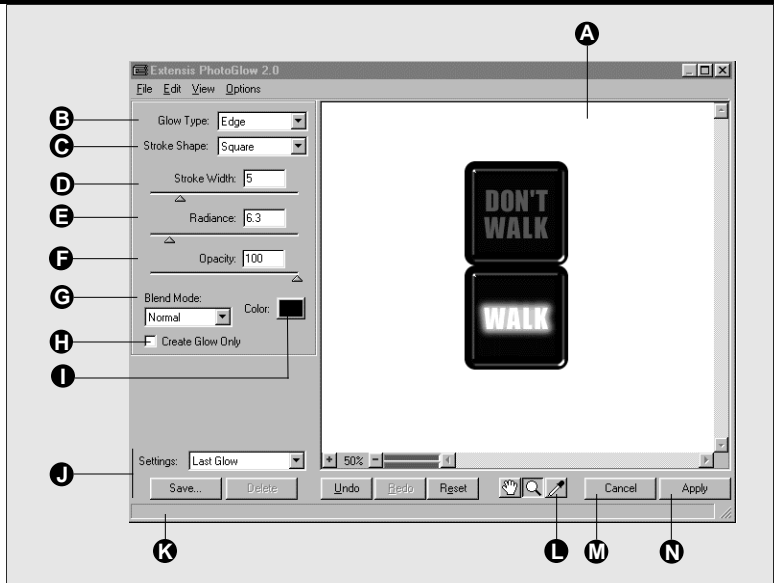

**J** Settings controls: Save, Select, and Delete effect Settings.

**K** Help Box: Displays a description of each tool or option as the mouse passes over it.

**L** Eyedropper: Extracts a glow color from the preview.

**M** Cancel: Closes the dialog box without making changes to the image. You can also Cancel by pressing Command+“.” (Macintosh) or ALT+F4 (Windows).

**N** Apply: Adds your selected effects to the image and closes the dialog box. You can also Apply the effect by pressing Return or Enter.

# PhotoBars

---

PhotoBars brings the one-click convenience of toolbar buttons to Photoshop, giving you instant access to hundreds of Photoshop commands, tools, and menus. If a menu item or keyboard command is available inside of Photoshop, from either the Photoshop application or a plug-in, it can be made available for instant access on a PhotoBars toolbar.

With PhotoBars, you no longer need to constantly access buried menus—simply drag buttons containing the commands you use most often onto a toolbar, and have those commands available in one click. And if you’re working on a Macintosh, simply enable SmartBar: SmartBar watches as you select commands, then automatically creates a toolbar for them.

## PhotoBars turns this

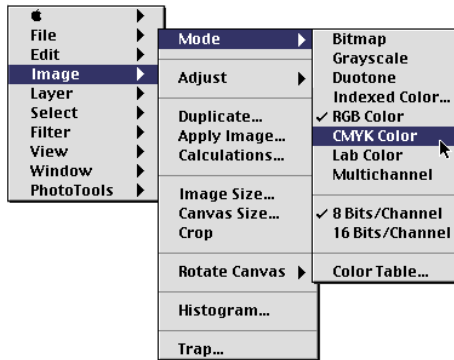

## Into this



PhotoBars includes several popular preconfigured toolbars to show you just how convenient toolbars can be. The commands on these toolbars are ones that most Photoshop users will find useful. But since work patterns and preferences differ, PhotoBars gives you the power to customize your toolbars: you can add, remove, and rearrange buttons according to your preference. You can hide and unhide your toolbars to reflect your work in different files and projects, and you can have your toolbars “float” freely in the Photoshop window, or “embed” them along any edge of the window—and instantly change from floating to embedded and back again.

If you find yourself repeating the same commands over and over again, those commands probably belong on a toolbar. By spending just a few minutes learning how to work with PhotoBars, you can save hundreds of steps and drudgery on every project!

## Getting Started with PhotoBars

---

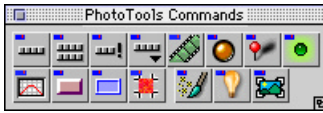

Typical Floating Toolbar

When Photoshop is first opened after PhotoTools has been installed, the PhotoBars default toolbars will be displayed. The default toolbars contain preselected buttons, and each button represents either a Photoshop or a PhotoTools command.

You can start with the default toolbars to rearrange, add or remove buttons, or to float, embed or hide the toolbars, or even delete them. And don't worry—even when you delete a toolbar the commands and buttons used to create them are still available. So you can recreate a toolbar, or a create a similar one, at any time.

If you're not interested in using a particular toolbar, simply click the "close" box to hide it. You can display it again at any time by selecting "PhotoBars" from the Extensis menu, then selecting the toolbar you wish to display.

### To Determine Button Function:

**Position the mouse pointer over the button.**



The button's function will be displayed in the "Hot Help" pop-up.

*Note: You can turn off toolbars Hot Help at any time. Select Extensis > PhotoBars > Edit Toolbars, then click the box "Show Hot Help" (Macintosh) or "Show ToolTips" (Windows). No checkmark indicates that Hot Help is turned off.*

### To Hide a Toolbar:

Close (hide) toolbar

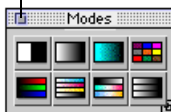

**Click the Close button.**

— or —

**Select Extensis > PhotoBars > Edit toolbars. Select the toolbar you wish to hide.**

— or —

**Select Extensis > PhotoBars, then select the toolbar you wish to hide** (visible toolbars are indicated with a check).



### To Show (Unhide) a Toolbar:

- **Click the Edit Toolbars button on the PhotoTools Commands toolbar, then click the toolbar you wish to show** (hidden toolbars have no checkmark).
- *or* —
- **Select Extensis > PhotoBars > Edit toolbars. Select the toolbar you wish to show.**
- *or* —
- **Select Extensis > PhotoBars, then select the toolbar you wish to show.**

### Floating Toolbars and Embedded Toolbars

Any PhotoBars toolbar can be displayed as either a “floating palette” toolbar or an “embedded” toolbar.

A *floating palette* toolbar is a group of buttons that can be moved to any location on the screen. The advantage of floating palettes is that they can be dragged anywhere in the screen that’s convenient; they can be reshaped in any combination of rows and columns; they can be given a name for easy recognition; and they can be hidden until needed. An *embedded* toolbar is a row or column of buttons attached to one side of the window. Embedded toolbars cannot be resized—but they can be instantly changed to floating toolbars. The advantage of embedded toolbars is that they’re at the outside edge of the work area: out of the way, yet close enough to be accessed quickly.

PhotoBars makes it easy to change back and forth between the two types, so you can have some toolbars one style and some the other—and easily switch back and forth between them.

### To Change a Toolbar from Floating to Embedded:

- **Click in the title bar or empty gray area on the toolbar (not a button), then drag the toolbar to any edge of the screen and release.**
- *or* —
- **Double-click in the title bar or empty gray area on the toolbar (not a button).**

The toolbar will automatically be embedded in the location it was last embedded. If it has never been embedded, it will embed to the nearest edge of the window.



Floating Toolbar

Embedded  
Toolbar



### To Change a Toolbar from Embedded to Floating:

- Click in either the title bar or the empty gray area on the toolbar (not a button), then drag the toolbar away from the edge of the screen. Release the mouse where you'd like to place the toolbar.

— or —

- Double-click in the title bar or empty gray area on the toolbar (not a button).

The toolbar will immediately turn into a floating palette and placed where it was last positioned as a floating toolbar. If it was never a floating toolbar, it will be placed in the upper-left corner of the window.

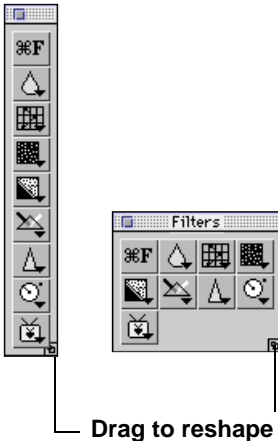

### To Resize (Reshape) a Floating Toolbar:

- Drag the toolbar from the grow box in the bottom right corner (Macintosh) or from the bottom corner (Windows). Release when the toolbar is the desired shape.

You can pull the toolbar in any direction to resize it, making it fully vertical, fully horizontal, or anything in between.

## Customizing Toolbars

---

You can remove buttons, add buttons, add space between buttons to help group them logically, and move buttons from one toolbar to another. You may want to create some toolbars for commands that you use often, and other toolbars for commands that you use only with certain projects. You can also rename, duplicate, or remove your toolbars at any time.

### To Remove a Button from a Toolbar:

1. While pressing Command (Macintosh) or ALT (Windows), click and drag the button off the toolbar. Release the mouse when the button is no longer on the toolbar.

The icon will disappear.

*Note: This action deletes the button icon from the toolbar, but not from PhotoBars. The button can be retrieved from the button library at any time (Extensis > PhotoBars > Customize Toolbars). For detailed instructions refer to “To Add New Buttons to a Toolbar” on page 92.*

## To Add Space Between Buttons:

1. While pressing **Command (Macintosh) or ALT (Windows)**, click and drag the button to the left or to the right only slightly, then release.

*Note: It takes just a small amount of movement to add space between buttons. You may have to experiment a little to get just the right touch for spacing button icons.*

## To Rearrange Buttons On or Between Toolbars:

1. While pressing **Command (Macintosh) or ALT (Windows)**, click and drag the button to its new location, then release the mouse.

You can drag a button to any location on a toolbar, or drag it to another toolbar (both toolbars must be showing).

*Note: If you drag a button around and release it when it is not positioned over a toolbar, the button will disappear. Remember that this is how you remove a button from a toolbar, and it can happen accidentally. To retrieve the button, select **Extensis > PhotoBars > Customize Toolbars**. Locate the button and drag it back onto your toolbar. For help see “To Add New Buttons to a Toolbar” on page 92.*

### Tip

You can also create a new toolbar from the Customize Toolbars dialog box—simply drag a button from the Buttons window to the Photoshop window.

## To Create a New a Toolbar:

1. Click the **Edit Toolbars** button on the **PhotoTools Commands** toolbar.

— or —

1. From the **Extensis** menu select **PhotoBars > Edit Toolbars**.
2. Click “**New**.”

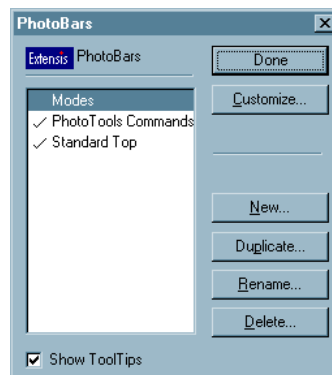
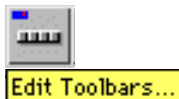

### 3. Enter a name for your toolbar.

### 4. Click “Done.”

A blank toolbar will be created and placed in the upper-left portion of the Photoshop window. Drag your new toolbar to a convenient location.



### 5. Add buttons to your new toolbar.

Either drag buttons from existing toolbars (the toolbar must be visible for you to do this), or add buttons from the Customize Toolbars dialog box (as described in the next section.)

## To Add New Buttons to a Toolbar:

### 1. Click the Customize Toolbars button on the PhotoTools Commands toolbar.

— or —

### 1. From the Extensis menu select PhotoBars > Customize Toolbars.

The Customize Toolbars dialog box will appear, showing all the Categories of available buttons. Each Category represents a menu in Photoshop.

### 2. From the “Categories” window, locate the category of commands that represents the command you are interested in.

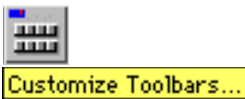

## Tip

**Macintosh Users:** You can automate the toolbar creation process with SmartBar. SmartBar will “watch” you work and automatically record your commands as you invoke them, then instantly create a toolbar of those commands. Refer to “Creating Toolbars with SmartBar” for more information.

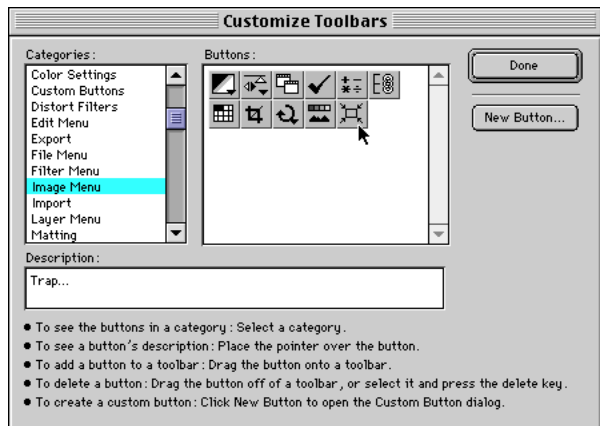

All the buttons associated with commands in the selected category will be displayed in the “Buttons” box on the right hand side of the window.

3. From the “Buttons” window, select the button representing the command that you want to add to your toolbar.

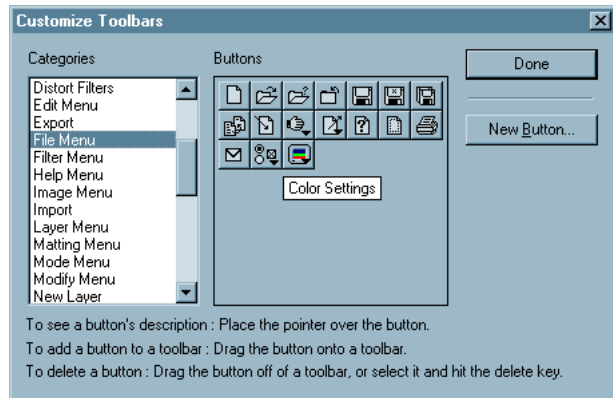

To determine which button represents which command, pass the mouse over each button. A description of the button will appear in the “Description” Help box in the center of the screen (Macintosh) or as a pop-up ToolTip (Windows).

4. Drag the button to your toolbar and release.
5. Repeat steps 1 through 4 for all the commands you want to add to your toolbar.

If a button doesn’t “land” on the toolbar where you want it, simply drag it into the correct position. You may want to add all your buttons first, then experiment with positioning.

### Tip

**Macintosh Users:** You can use PhotoBar buttons to access files, folders, and other applications.

For example, you might want to create a button that will show you a pop-up list of all images in a particular folder on your hard drive.



To open the image in Photoshop, simply select it from the list.

## Windows Users

Refer to page 101, “Creating New Buttons (Windows).”

## Tip

You won’t have to create new buttons often—every menu and sub-menu item in Photoshop, including Plug-ins and Filters, has a button already created for it in PhotoBars. You’ll only need to create new buttons to add a button for third-party Plug-ins, Filters, etc., or to add a file or folder to your toolbar(s).

For more information on adding buttons to a toolbar, see “To Add New Buttons to a Toolbar,” on page 92.

## Creating New Buttons (Macintosh)

While there are hundreds of predefined buttons available in PhotoBars (for Photoshop and PhotoTools commands), other commands that you use frequently may not have a predefined icon. These might include commands associated with add-on filters, additional plug-ins, special keyboard functions, etc. However, if the command is accessible in Photoshop, either by menu or by key command, you can create a button for it and access it from a PhotoBars toolbar.

### To Create a Button for a New Command (Macintosh):

1. Click the **Customize Toolbars** button on the **PhotoTools Commands** toolbar.

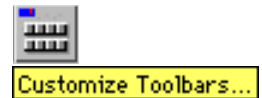

— or —

1. From the **Extensis** menu, select **PhotoBars > Customize Toolbars**.
2. Click “**New Button.**”
3. Click “**Select Icon.**”
4. Select an icon for your button.



Scroll through the icons in the icon library and click an icon to select it.

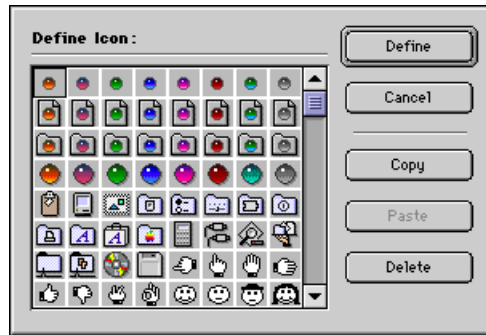

*Note: You can add your own buttons to the icon library. Refer to “Adding Your Own Button Icons” on page 100.*

5. Click “**Define.**”

This closes the Define Icons dialog, and displays the selected icon in the Edit Custom Button dialog.

Verify that your selected icon appears in the Edit Custom Button dialog box.

Icon selected



## 6. Select “Keystroke,” “Menu,” or “Finder Item.”

If the command you wish to create a button for is invoked with a keystroke, select “Keystroke.”

If the command appears on a Photoshop menu, select “Menu.”

If you’re creating a button to access a file, folder, or application, click “Finder Item.”

## 7. Depending on which option you chose, refer to the appropriate section below.

### To Create a Button for a Keyboard Command (Macintosh):

1. If you have not already done so, open the Customize Toolbars dialog and select an icon as indicated in “To Create a Button for a New Command” on page 94.
2. Select the “Keystroke” option.
3. Click “Select...”

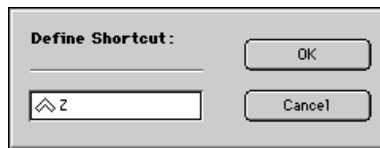
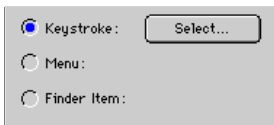

4. Type the keystrokes that invoke your command.
5. Click “OK.”

Verify that your selected keystrokes appear next to the “Select...” button in the Edit Custom Button dialog box.

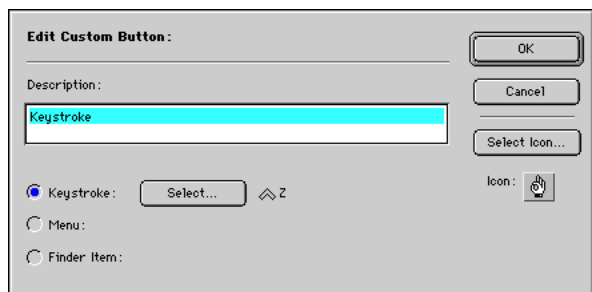

## 6. Click “OK.”

Your new button will be displayed in the category “Custom Buttons” in the Categories window of the Customize Toolbars dialog box.

## 7. Drag your new button onto a toolbar.

*Note: Whether or not you drag your button onto a toolbar, it will remain in the Custom Buttons category until you delete it.*

## 8. You can define more buttons, or click “Done” to return to Photoshop.

### To Create a Button for a Menu Command (Macintosh):

#### 1. If you have not already done so, open the Customize Toolbars dialog and select an icon as indicated in “To Create a Button for a New Command” on page 94.

#### 2. Select the “Menu” option.

A pop-up menu appears to the right of the Menu radio button. This pop-up allows you to scroll through the menus until you find the menu item command that you wish to attach to your custom button.

#### 3. Select the menu command you are creating a button for.

Verify that your selected menu command appears next to the pop-up menu button in the Edit Custom Button dialog box.

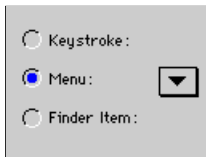

#### 4. Click “OK.”

Your new button will be displayed in the category “Custom Buttons” in the Categories window of the Customize Toolbars dialog box.

#### 5. Drag your new button onto a toolbar.

*Note: Whether or not you drag your button onto a toolbar, it will remain in the Custom Buttons category until you delete it.*

#### 6. You can define more buttons, or click “Done” to return to Photoshop.



## To Create a Button for a Finder Item (Macintosh only):

1. If you have not already done so, open the Customize Toolbars dialog and select an icon as indicated in “To Create a Button for a New Command” on page 94.



2. Select the “Finder Item” option.

A dialog appears, asking if you want to attach a file or a folder to the custom button.

3. Select “File” or “Folder.”

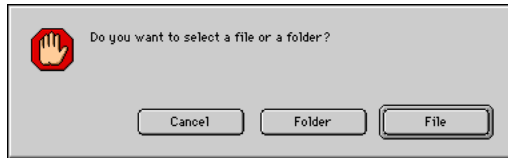

If you attach a file to the button, the file will be opened when you click the button. If you attach an application, the application will be launched when you click the button.

If you attach a folder to the button, folder contents will be displayed in a pop-up menu when you click the button.

4. Locate the file or folder.
5. If you are selecting a file, highlight the file then click “Open.” If you are selecting a folder, highlight the folder then click “Select.”

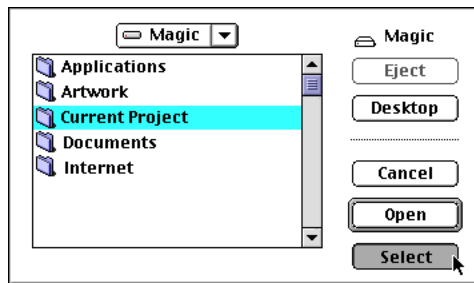

Verify that your selected file or folder appears next to the “Select...” button in the Edit Custom Button dialog box.

## Tip

Note: Whether or not you drag your button onto a toolbar, it will remain in the Custom Buttons category until you delete it. To delete an icon from the Buttons window in the icon library, select (click) it and press the Delete key.

## 6. Click “Done.”

Your new button will be displayed in the category “Custom Buttons” in the Categories window of the Customize Toolbars dialog box.

## 7. Drag your new button onto a toolbar.

## 8. You can define more buttons, or click “Done” to return to Photoshop.

## Using the SmartBar to Create Toolbars (Macintosh Only)

SmartBar is a floating palette that automates the task of creating buttons and toolbars. SmartBar records your menu selections and commands, then allows you to save those recorded commands as a toolbar.

When the SmartBar palette is open and enabled, each time you invoke a menu item or other command it is recorded on the palette. Up to 15 commands can be shown in the SmartBar palette at one time. When you’re ready, you can click a button on the palette and convert those commands into a toolbar. From then on, instead of selecting commands from pulldown menus, you can click the buttons to invoke your commands.

### To Open the SmartBar Palette (Begin Recording):

1. Click the Show/Hide SmartBar button on the PhotoTools Commands toolbar.

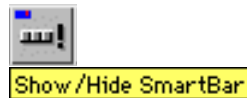

— or —

1. From the Extensis menu choose PhotoBars, then select Show SmartBar.

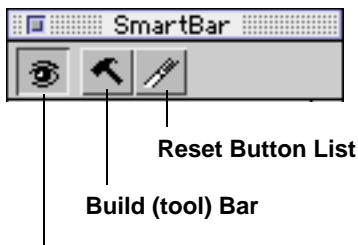
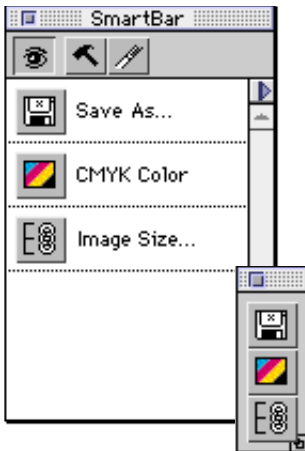

Watch Me button  
(Toggles SmartBar  
on and off)

### To Turn SmartBar On or Off (Start or Stop Recording):

1. **Once the SmartBar palette is open, you will see the Watch Me button (the button with the eye on it). Click this button to turn SmartBar on and off.**



When the eye is open, SmartBar watches you while you work and creates a button for you when you choose a Photoshop menu command.



When the eye is closed, SmartBar is turned off.

Once SmartBar has created a button for your command and added it to the palette, you can use the button immediately by simply clicking on it in the SmartBar list.

SmartBar lists up to the last 15 commands you have used. After this, when a new command is added the oldest is deleted.



### To Create a Toolbar from the Commands in the SmartBar:

1. **Click the “Build Bar” (hammer) button to create a new toolbar containing all the buttons listed in the SmartBar palette.**

If you only want some of the listed buttons to be in a new palette, hold down the Command key and click on the names (not the icons) of the buttons you want to include in the new toolbar before you click the “Build Bar” button.

### To Copy a Button from the SmartBar to Another Toolbar:

1. **Hold down the Command key and drag the button icon from the SmartBar list to the toolbar you want to place it in.**



### To Clear the SmartBar Button List:

1. **Click the “Reset List” button in the SmartBar palette.**
2. **Click OK.**

## **Adding Your Own Button Icons (Macintosh)**

You can create your own icons for toolbar buttons. You can use any of the icons in the PhotoBars button library, you can use any Macintosh paint program, including Photoshop, to design your own icons, or you can copy a small image to the clipboard and paste it into the icon library.

### **Tip**

For best results, custom designed icons should be 19 x 17 pixels (width x height).

### **To Add a Button Icon to the Icon Library:**

#### **1. Create a custom button icon.**

Icons that you create should be 19 pixels wide by 17 pixels tall. Use Copy and Paste (*see Note with step 5, below*) to place your icon on the Clipboard. Once a custom designed icon is on the Clipboard, it can be pasted into the PhotoBars icon library. PhotoBars will automatically add a border to your icon, and will alert you if the pasted icon is not the correct size.

#### **2. Click the Customize Toolbars button on the PhotoTools Commands toolbar.**

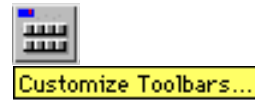

Or select Extensis > PhotoBars > Customize Toolbars.

#### **3. Click “New Button.”**

#### **4. Click “Select Icon.”**

The Define Icons dialog box appears.

#### **5. Click “Paste.”**

Your new icon will be pasted into the icon library as the last item on the list.

*Note: If you copy your image on to the Clipboard from Photoshop, you must switch out of Photoshop, then back in, before the Clipboard will allow you to paste the icon into the icon library.*

#### **6. If you wish to define a button using your new icon, click “Define.” If you wish to keep your new icon in the library but do not wish to define a button at this time, click “Cancel.” If you do not want to keep your new icon, click “Delete” and then “Cancel.”**

## Tip

You won't have to create new buttons often—every menu and sub-menu item in Photoshop, including Plug-ins and Filters, has a button already created for it in PhotoBars. You'll only need to create new buttons to add a button for third-party Plug-ins, Filters, etc.

*For more information on adding buttons to a toolbar, see "To Add New Buttons to a Toolbar," on page 92.*

## Creating New Buttons (Windows)

While there are hundreds of predefined buttons available in PhotoBars, other commands that you use frequently may not have a predefined button. These might include commands associated with add-on filters, additional plug-ins, special keyboard functions, etc. If the command is accessible in Photoshop, either by menu or by key command, you can create a button for it and access it from a PhotoBars toolbar.

### To Create a Custom Button:

1. Click the **Customize Toolbars button on the PhotoTools Commands toolbar.**

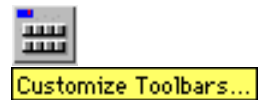

— or —

1. In the **Edit Toolbars... dialog box** click **"Customize."**

— or —

1. **Select Customize Toolbars... from the PhotoBars sub-menu of the Extensis menu.**

The **Edit Custom Button dialog box** appears.

2. **Click the New Button button.**

The **Icon Button Editor dialog box** appears. Custom buttons can represent Keystrokes, Photoshop menu items, or Plug-in items.

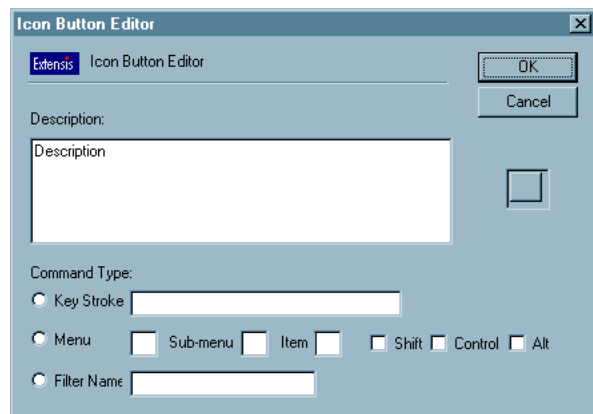

3. **Click the Keystroke, Menu, or Filter button.**

#### **4. Provide PhotoBars with additional information about the button.**

**Keystroke:** If you selected Keystroke, click in the field next to “Keystroke” and type in your command. You cannot use ALT key combinations as these are reserved in Photoshop.

**Menu:** If you selected Menu, enter the menu and menu item numbers corresponding to the desired menu item. The menu numbers in Windows start counting at 0 for the File Menu, 1 for the Edit Menu, etc. A pull-down menu is -1. For example: To select the Image Adjust menu item, you would enter 2, 2, -1.

**Filter:** If you selected Filter, click in the Filter Name field and type in the filter name exactly as it appears on the menu.

A description of the button command appears in the Description field. You can edit the button description by changing the text in this field.

#### **5. Click OK.**

The button is added to the Custom Buttons category. You can add the Custom button to a toolbar, just as you would a pre-defined button.

### **Adding Your Own Button Icons (Windows)**

You can create your own icons for toolbar buttons using any Windows paint program.

#### **To Add a Button Icon to the Icon Library:**

- 1. Design an icon in any Windows paint program. The button must be 19 pixels wide by 17 pixels tall and be a 16-color image.**
- 2. Copy your icon to the Clipboard.**
- 3. Open Photoshop and the Customize Toolbars... dialog.**
- 4. Click New.**
- 5. Define settings for the new button.**
- 6. Click the Button icon on the right side of the dialog box.**

The icon is added to those shown in the dialog box. An alert box appears if the pasted icon is not the correct size.

# PhotoAnimator

---

Extensis PhotoAnimator is a stand-alone application that helps you create stunning and exciting animations with almost no effort. You start with raw animation elements saved either in native Photoshop format (.psd), or as GIF images (.gif), then use PhotoAnimator's intuitive tools to add special effects to create the animation, or import existing animations and use PhotoAnimator to enhance them. And because PhotoAnimator is a stand-alone application, you don't need to have Photoshop open to use it.

## PhotoAnimator System and Software Requirements

---

To install and use PhotoAnimator, you will need the following:

### Macintosh:

- Power Macintosh® or equivalent
- Mac OS® System 7.5 or higher
- 8MB free hard disk space for PhotoAnimator, the PhotoAnimator User Guide PDF, and Tutorial Sample Files

### Windows:

- PC with Pentium processor or faster
- Microsoft® Windows 95® or Windows NT® 4.0
- 8MB free hard disk space for PhotoAnimator, the PhotoAnimator User Guide PDF, and Tutorial Sample Files

## PhotoAnimator Tutorial Sample Files

---

By default, the installer will place the PhotoAnimator Tutorial Sample Files in the following locations:

### Macintosh:

- Application—Hard disk: PhotoTools: PhotoAnimator™ 1.0
- Tutorial Sample Files—Hard disk: PhotoTools: PhotoAnimator™ 1.0: Tutorials

### Windows:

- Application—C:\Program Files\Extensis\PhotoTools\PhotoAnimator™ 1.0
- Tutorial Sample Files—C:\Program Files\Extensis\PhotoTools\PhotoAnimator™ 1.0\Tutorials

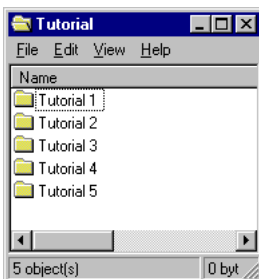

## Getting Started with PhotoAnimator

---



PhotoAnimator™ 1.0

Open the PhotoAnimator Application

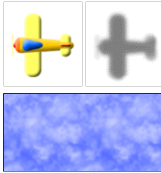

Import Raw Elements

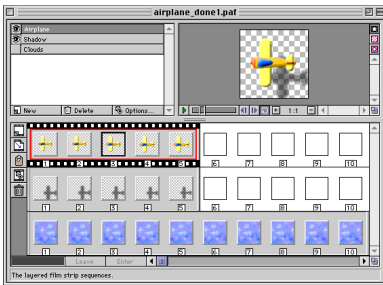

Apply Unlimited Special Effects

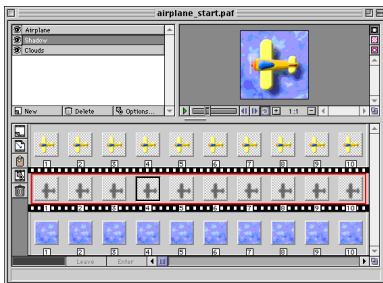

Instant Animation!

- 1) Open PhotoAnimator and specify a display size for the animation. Since PhotoAnimator is a stand-alone application, you can open it like you would any other application. PhotoAnimator can also be launched from within Photoshop by choosing it from the Extensis menu in the Photoshop menubar (Extensis > PhotoAnimator).

*Note: If you wish to import images from Photoshop into PhotoAnimator, you must close them in Photoshop before PhotoAnimator will be able to open them.*

- 2) Import raw animation element files (.psd, .gif).
- 3) Apply special effects and play back your animations as you design them. Loop your sequences or play them frame by frame—you can even use multiple windows to compare and contrast effects—until you achieve just the effect you want.
- 4) When the design is complete, export out as a GIF Animation.

Unlike frame-by-frame animation programs, PhotoAnimator allows you to use layers and to apply effects to resizable cells. You can animate each layer independently, and combine them however you like. With PhotoAnimator you have the freedom to edit your animations to your heart's content, previewing as you create them, rather than being limited to viewing the results after all the frames have been created.

Each animation layer can have multiple cells, and each cell can have its own effect applied to it. PhotoAnimator automatically generates the specified effect over a range of cell frames. You can easily expand or contract the number of frames in a cell, and PhotoAnimator will automatically recalculate the effect for the entire cell.

By combining PhotoAnimator's special Image, Mask, Transition and Filter effects like scale, rotate, spin, fade, wipe, barn door, gradient mask, and invert, the possibilities for striking and professional-looking animations are virtually endless.



## PhotoAnimator window

- A** PhotoAnimator Title Bar: Displays the file name of the animation.
- B** Preview Pane: Displays a preview of the animation which is always available and can be viewed from any dialog box as you work with animation effects. This pane also provides access to tools and options for working with the preview. *See page 106 for more information.*
- C** Image Preview: Displays the animation and all visible layers.
- D** Layers Pane: Lists animation layers. Functions like the Photoshop Layers palette, allowing you to create, name, hide, delete, and reposition layers. *See page 106 for more information.*
- E** Grow Bar: Click and drag up or down from the center to enlarge or reduce the Filmstrip pane, allowing you to show or hide layers.
- F** Filmstrip Pane: Displays the cells and frames that make up the animation. Layers in this pane correspond to the layers in the Layers pane. This pane also provides access to tools and options for working with the cells, frames, and images. *See page 107 for more information.*
- G** Flicker Help Box: Displays a description of each tool or button function as the mouse passes over it.

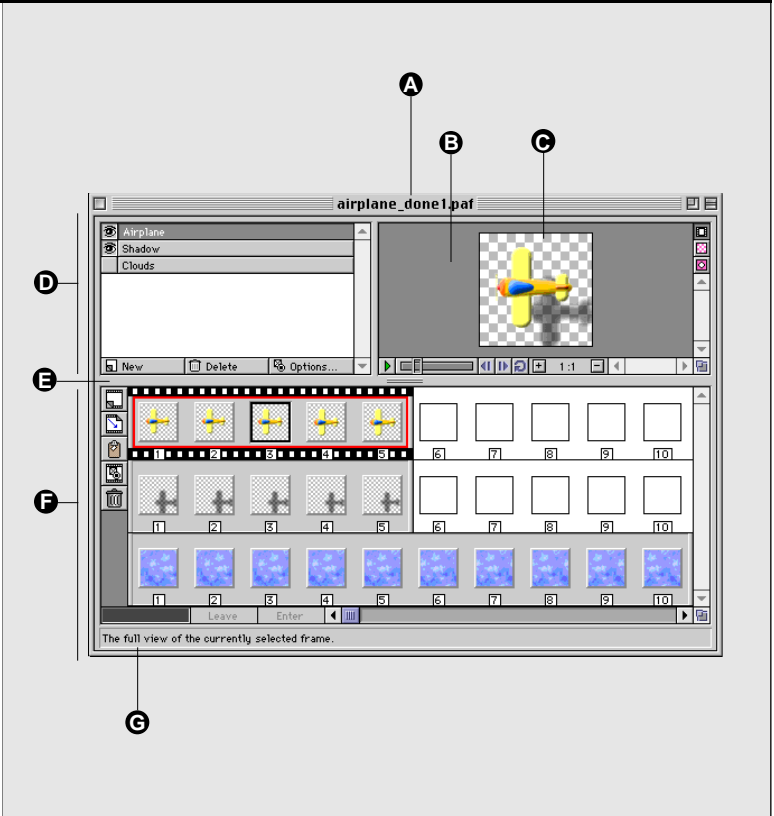

### Tip

For a quick introduction to the tools, windows, and basic operations in PhotoAnimator, we suggest you complete the first PhotoAnimator tutorial "Getting Started—Basic Animations" starting on page 120 of this User Guide.

For an introduction to some of the stunning special effects available in PhotoAnimator, turn to Tutorials 2 through 5 starting on page 130.

The PhotoAnimator window is the primary window, containing three separate panes: the Layers Pane, the Preview Pane, and the Filmstrip Pane.

**Layers Pane:** Displays all the layers available for the animation. Each layer can contain from one to 300 animation frames. This pane functions similar to the Photoshop Layers palette, allowing you to create, name, hide, delete, and reposition layers.

**Preview Pane:** Displays a preview of the animation. This preview is always available and can be viewed from any dialog box as you work with animation effects.

**Filmstrip Pane:** Displays the cells and frames that make up the animation. Layers in this pane correspond to the layers in the Layers pane. This pane also provides access to tools and options for working with the cells, frames, and images.

## PhotoAnimator window—Layers Pane

- A** Layer Name: Displays the layer by name. Highlighted name indicates the currently active layer in the Filmstrip window. Drag the name up or down the list to reposition the layers.
- B** Show/Hide Layer: Determines whether a layer is visible in the animation image in the Preview pane. Eye icon indicates showing, no Eye icon indicates hidden. Only layers with an Eye icon present will be included in the animation when it is exported.
- C** New Layer: Click to create a new (empty) layer.
- D** Delete Layer: Click to delete the selected layer.
- E** Layer Options: Change layer name; make visible or invisible.



## PhotoAnimator window—Preview Pane

- A** Preview: Displays the full animation sequence when the Player is on. Displays the contents of the currently selected frame when the Player is off. Display is affected by the settings of the layer Show/Hide buttons.
- B** Start/Stop: Press to start and stop the animation. *You can also press the Spacebar to start and stop the animation.*
- C** Animation Player: Drag the slider to interactively move through the full animation (affected by Layer settings).
- D** One-step buttons: Click back and forth through the animation one frame at a time.
- E** Loop: Places the Player in continuous-play mode when depressed.
- F** Zoom: Click "+" to Zoom In (enlarge the Preview), click "-" to Zoom Out (reduce it).
- G** Display Composite: Displays the composite preview of all visible layers of the current frame.
- H** Display Frame: Displays contents of the currently selected frame only.
- I** Display Transition: Displays currently selected frame transition.

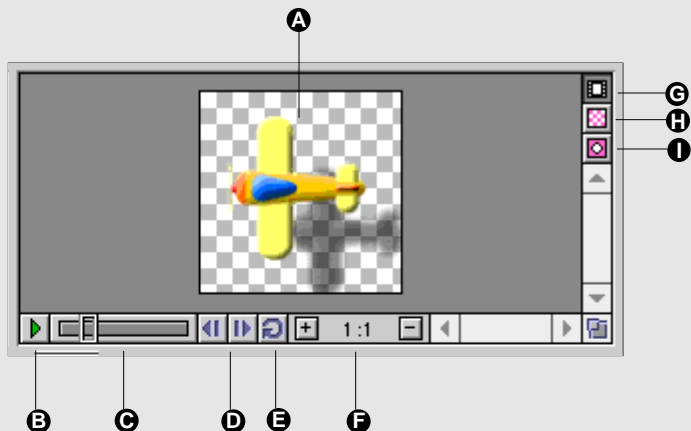

## PhotoAnimator window—Filmstrip Pane

- A** New Cell: Click to create a new (empty) cell in the selected layer.
  - B** Import Image: Click to create a new cell in the selected layer and import an image directly into it. Automatically displays the appropriate Import Options dialog.
  - C** Clipboard Icon: Cut an animation cell by dragging it to the clipboard icon. Paste the cell by dragging the clipboard icon to the desired location. To copy the cell, **Option+drag** (Macintosh) or **Alt+drag** (Windows).
- You can also cut or copy to the clipboard using the standard cut, copy, and paste commands. Pasting the cell places it at the end of any existing cells in the layer.
- D** Open Effect Settings: Click to open the Effect Settings dialog for the currently selected cell. *You can also double-click the cell to access the Settings dialog once an effect has been applied.*
  - E** Trash Icon: Delete (remove) the selected cell.
  - F** Frame: 300 maximum frames per layer. Black border indicates currently selected frame.
  - G** Animation Cell: Consists of one or more frames. Filmstrip outer border indicates currently selected layer. Red inner border indicates currently selected cell.
  - H** Empty Cell: Shows a one-frame wide empty cell.
  - I** Cell End Marker: Drag to increase or decrease number of frames in a cell.
  - J** Frame place-holder: Empty position; contains no frame or cell.
  - K** Redraw progress bar: When complete, indicate entire animation is loaded into memory.
  - L** Flicker Help Box: Displays a description of each tool or function as the mouse passes over it.
  - M** Leave/Enter: Enter or exit the Nested Sub-Animation work area.
  - N** Animation Layers: These correspond to the layers listed in the Layers Pane (see page 8).

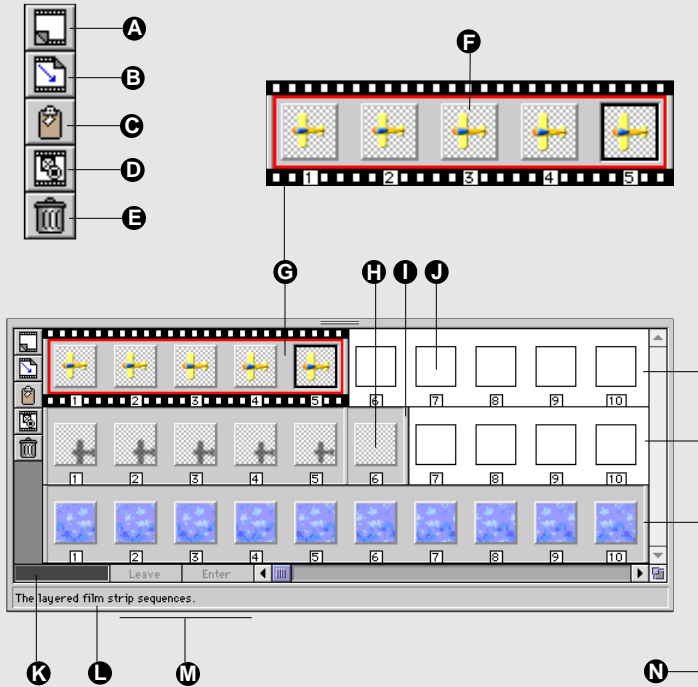

**Frame:** A single image; the smallest unit in PhotoAnimator. Frames contain raw images. Maximum 300 frames per Layer. Multiple frames make up a cell.

**Cell:** Consists of one or more frames. All the frames in a cell contain the same image. Animation effects are applied to cells. The effect may change the image gradually between the first frame of the cell and the last frame of the cell, to create the pieces of the total animation, such as transitions from visible to invisible, horizontal or vertical movement over time, spins, etc.

**Layer:** Consists of one or more cells. Layers are combined to create the full animation. A background layer, for example, might consist of a single cell with multiple frames with no effects applied to the image. A background layer would typically be the bottom layer. An animation layer, such as a filmstrip showing a stunt plane in action, would typically be the top-most layer. The animation layer might contain a number of different cells with a different effect applied to each cell. When the cells are played in succession they would simulate the movement of the plane: scaling to show to perspective (movement far to near), rotation to simulate spinning, etc. An example of this effect is shown in Tutorial 1, which starts on *page 120*.

### Tip

Once an effect has been applied to a frame, simply double-click the frame to open the appropriate effect settings dialog box. Or select any frame in a cell and press **Command-T [Ctrl+T]**.

**Effects:** Effects allow you to create the illusion of movement. Effects are applied to cells. Because they simulate movement, effects are typically applied to cells containing more than one frame, and may affect the individual frames within the cell differently. Effects are accessed from the Effect menu in the menu bar.

**Animation Player:** The animation Player, located on the Preview Pane, controls the image in the Preview window. The Player allows you to play back the animation in a continuous loop or frame by frame. Another Player, available from the dialog box of each of the Effect Settings, allows you to step through the animation sequence of a single cell. By hiding and showing layers and then stepping one by one through the frames of a single cell, you can see how your Effect Settings on that cell will affect the overall animation.

Animation	
Frame Size...	⌘F
Frame Rate...	⌘G
New Layer...	⌘L
Delete Layer	
Layer Options...	
New Cell	⌘K
Delete Cell	
Resize Cell...	

### Tip

To create a new Layer, press **Command-L [Ctrl+L]**.

To create a new Cell, press **Command-K [Ctrl+K]**.

## Animation Functions and Settings

**Frames:** Two Animation settings—Frame Size and Frame Rate—allow you to specify how large the display window for your animation will be, and to how quickly or slowly the frames will play. The Frame Size dialog can also be opened by pressing **Command-F [Ctrl+F]**. Access the Frame Rate dialog with **Command-G [Ctrl+G]**.

**Layers:** From the Animation menu you can create, delete, and rename layers, and specify whether the selected layer is visible or invisible. A filmstrip border indicates the currently selected layer. Layer options can also be invoked using the buttons on the left side of the Layers Pane (*see page 106*).

**Cells:** From the Animation menu you can create and delete cells, and specify cell size. A red outline indicates the active cell. Cell options can also be invoked using buttons and sliders on the Filmstrip Pane (*see page 107*).

### Frame Size and Frame Rate Settings

- A Frame Size Settings
- B Width and Height: Enter custom frame size, in pixels.
- C Common Sizes Buttons: Select from eight commonly used sizes. Clicking a size button enters the selected size into the Width and Height fields.
- D Cancel: Close the settings dialog without making any changes.
- E OK: Close the settings dialog and apply the changes.
- F Frame Rate Settings
- G Total Frames: Displays the total number of frames in the animation.
- H Frame Rate (Frames/Second): Enter the desired frequency in frames per second.
- I Duration (in Seconds): Displays the duration of the animation based on the number of frames and the specified Frame Rate.

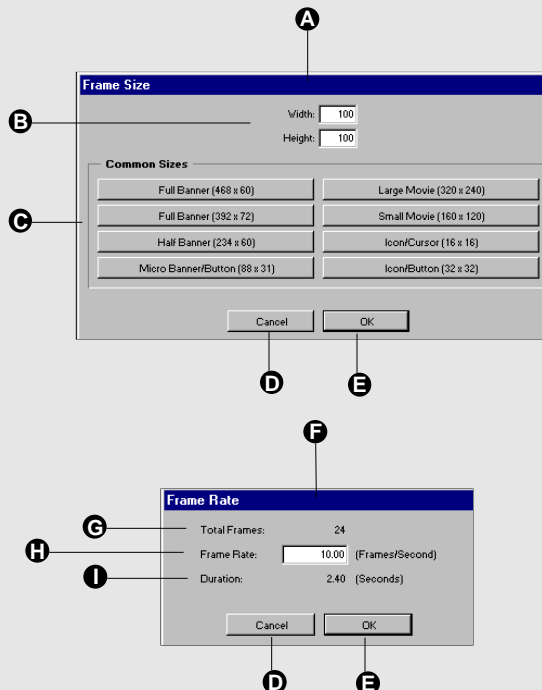

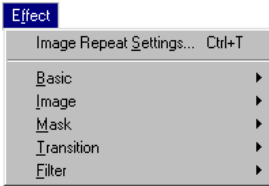

## Effect Settings

PhotoAnimator provides five categories of effects (Basic, Image, Mask, Transform, and Filter) that allow you to scale, rotate, spin, apply gradient masks, invert, and more. By combining these effects on different images over various size cells, the possibilities for unique and eye-catching animations are unlimited.

All of the Effect Settings dialogs allow you to temporarily apply the effect and preview the result on your animation without ever leaving the settings dialog. This gives you tremendous freedom to try out different effect settings and test your results without endlessly going back and forth between the settings dialog and the Preview Pane.

### To create an Effect:

1. **Select a frame and open the effect you are interested in by accessing it from the Effect menu.**

Effect options are described on *pages 110 through 116*.

2. **When you have the effect you want, click “OK” to apply the effect and close the dialog.**

### To Preview the Effect without closing the Effect Settings dialog:

1. **Move your windows around until you can see both the Preview pane of the PhotoAnimator window and the Settings dialog.**
2. **In the Settings dialog, click “Apply” to temporarily apply the effect.**
3. **Move the slider on the player in the Settings dialog box the see the effect on the selected cell in the Preview Pane.**
4. **If you don’t like the effect, click “Revert,” or change the settings, or click “Cancel” to close the dialog without making any changes to the cell.**

### Tip

You can access the last-used effect by pressing **Command-T [Ctrl+T]**.

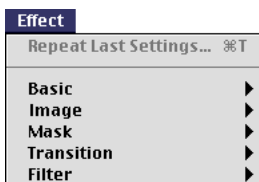

### Repeat Last Settings

Once you have set an effect for a frame, that same effect can easily be applied to other frames. To repeat an effect, either drag the cell border to the right, which instantly replicates the frame (thereby replicating the effect), or select or create a new frame, then select the first item on the Effect menu. The default setting for newly created cells is “Image Repeat Settings.”

## Common Effect Settings

The ability to preview your cell effects on the animation without closing the dialog (controls **G** through **K**) is common to all the Effects. Other controls shown here may not be found in all Effect dialogs.

- A** Import: Click to import an image into the selected cell.
- B** Export: Click to export the selected cell.
- C** Orientation Preview: Displays the current orientation of cell contents. Changes made to the Orientation controls affect this Preview. *Note: This is not an animation preview window.*
- D** Orientation Controls: Click the appropriate arrow to change the orientation of cell contents.
- E** Scale Settings: Specify Horizontal and Vertical "From" size "To" size, as a percentage of original size.
- F** Location: Displays a proxy of the location (relative position) of the content in the first frame of the cell. Drag the proxy to specify a new starting location, or enter coordinate values. See [page 14](#).
- Move To Location:** Click to allow frame contents to be repositioned as the cell progresses from first frame to last. Drag to specify the frame ending location, or enter coordinate values. See [page 14](#).
- G** Player: Move the slider to see the current Effect Settings on the selected cell. Click the right and left arrows to move forward and backward through the cell one frame at a time.
- H** Revert: Revert settings to the last saved state (undo Apply).
- I** Apply: Click to Apply the settings in order to preview the effect.
- J** Cancel: Click to close the dialog box without making any changes to the frame.
- K** OK: Click to Apply the effect and close the dialog box.
- L** Animation Preview: This is the Animation Preview pane of the PhotoAnimator window. Look here to view the animation as you operate the Player in an Effect Settings dialog.

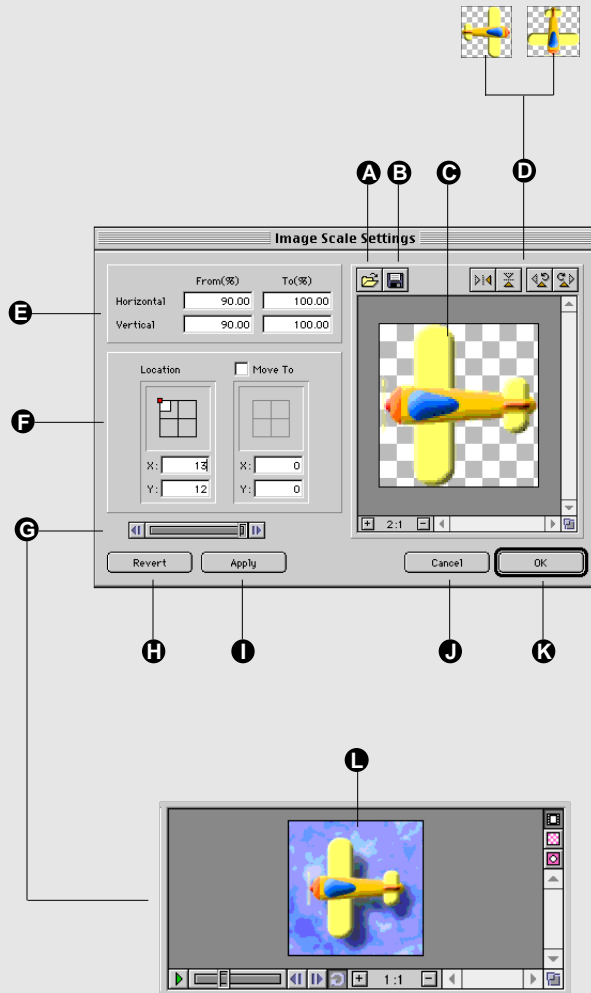

## Location Settings and Frame Content Proxies

The Location Settings allow you to use a proxy to indicate the relative position of frame contents in the first frame of the cell, and if "Move To" is enabled, the last frame of the cell. PhotoAnimator automatically adjusts frame content movement between the other frames in the cell.

- A** Location Settings: Indicates frame content starting and ending location in the cell.
- B** Location: Displays a proxy of the relative position of frame contents in the first frame of the cell. If no "Move To" location is specified, Location proxy indicates position of frame content in all frames of the cell. Drag proxy to adjust frame content starting location.
- C** "Move To" Enable: Click to access Move To location controls.
- D** Move To: Displays a proxy of the relative position of the content in the last frame of the cell. Drag proxy to indicate frame content ending location .
- E** Frame Grid: Representation of frame area as a square grid.
- F** Proxy: Red box sets the position point of frame content relative to the frame. White box represents actual frame content location in (or even outside of) the frame. (See **K through O** for additional information.)
- G** X and Y Offsets: Indicates frame content offset from from proxy (red box), in pixels. (See also **O**).
- H** Preview Controls: Allows you to preview effects without leaving the dialog. (See page 8.)
- I** Cancel: Click to close the dialog box without making changes.
- J** OK: Click to Apply the effect and close the dialog box.
- K** Proxy: Indicates upper-left corner of image is positioned in upper-left corner of frame.
- L** Proxy: Indicates lower-right corner of image is positioned out of the frame in the upper-left corner.
- M** Proxy: Indicates upper-left corner of image is positioned in center of frame.
- N** Proxy: Indicates center of image is centered in frame.
- O** Proxy Offset: Indicates center of image is centered in frame, then offset 30 pixels right and 30 pixels down.

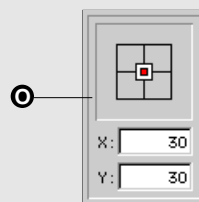
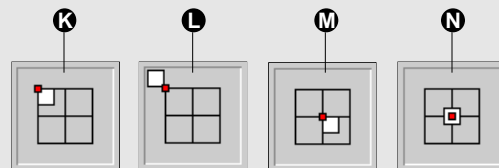
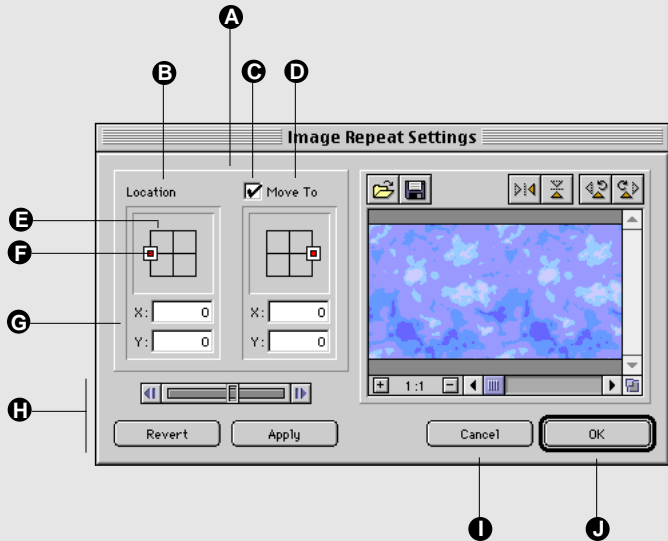



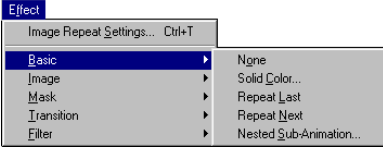

## Basic Effects

Basic effect options include None (applies no effect), Solid Color, Repeat Last, Repeat Next, and Nested Sub-animation.

*Note: For examples of Effects, refer to Tutorials 1 through 5 starting on page 120.*

## Basic Effects—Color and Nested Sub-Animation

The Solid Color effect allows you to color in your frames with a solid color. When selected, the Solid Color effect replaces any image already in the frame with the selected color.

- A** Color Mode Pop-up: Select RGB, CMY, HSV, Grayscale, or Web.
- B** Color Preview: Displays a preview of the selected color.
- C** Picker: Access the system color picker.
- D** Preview Controls: Allows you to preview effects without leaving the dialog. (See page 13.)
- E** Color Settings: Move the sliders until the desired color appears in the Color Preview, or enter values directly.
- F** Cancel: Click to close the dialog box without making any changes to the frame.
- G** OK: Click to Apply the effect and close the dialog box.

### Nested Sub-Animations

- H** Frame Action Pop-up: Select from Left Align, Right Align, Center Align, Left Repeat, Right Repeat, Center Repeat, Scale, Loop Modulate.
- I** Frame Size: Opens the Frame Size dialog (see page 11) to allow you to select or set frame size.
- J** Location and Move To Location: Allows you to specify starting and ending locations. (See page 14.)

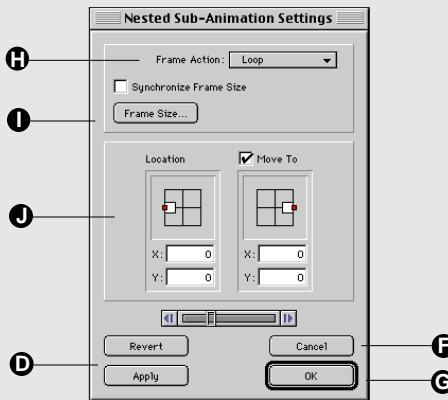
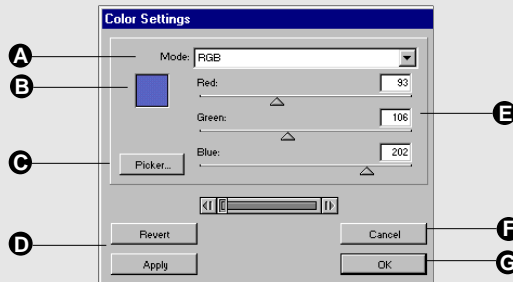

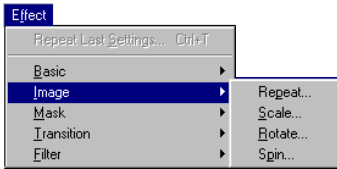

## Image Effects

Image Effects (Scale, Rotate, Spin) allow you to progressively change the size and/or orientation of objects between the first and last frame in the cell.

*Note: For examples of Effects, refer to Tutorials 1 through 5 starting on page 120.*

### Image Effects—Scale, Rotate, and Spin

Image Effects (Scale, Spin, Rotate) allow you to change the size and orientation of objects progressively between the first and last frame in the cell.

- A** Import/Export: Allows you to import an image into the selected cell or export the selected cell.
- B** Orientation Preview: Displays the current orientation of cell contents. Changes to the Orientation controls affect this Preview. *Note: This is not an animation preview window.*
- C** Orientation Controls: Click the appropriate arrow to change the orientation of cell contents.
- D** Scale Settings: Specify Horizontal and Vertical "From" size "To" size, as a percentage of original size.
- E** Location and Move To Location: Allows you to specify starting and ending locations. (See page 14.)
- F** Preview Controls: Allows you to preview effects without leaving the dialog. (See page 8.)
- G** Cancel: Click to close the dialog box without making any changes to the frame.
- H** OK: Click to Apply the effect and close the dialog box.
- I** Spin Settings: Specify how many revolutions the image will spin by entering a value in "End." Spin the image horizontally, vertically, or both. Image will appear to begin spinning in "mid-stream" by entering a value in "Start."
- J** Rotate Settings: Specify "From" Angle and "To" Angle (in degrees), and indicate Clockwise or Counter-clockwise rotation.

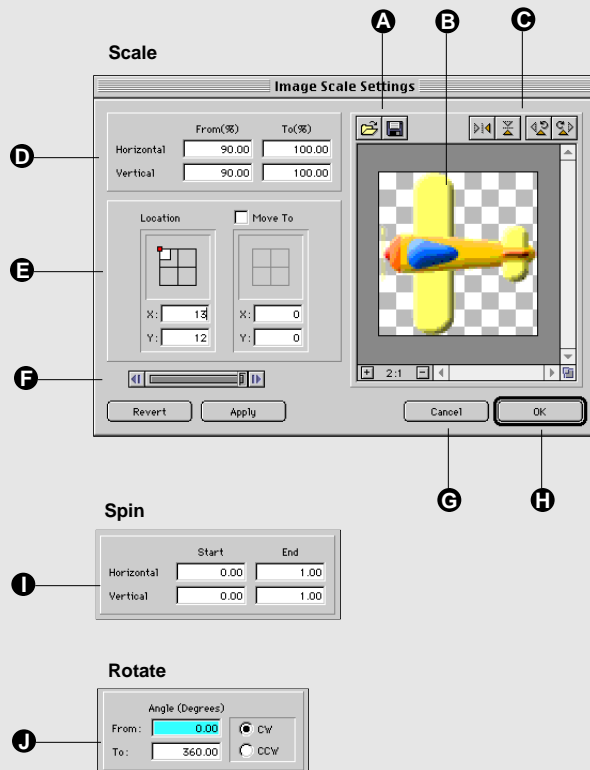

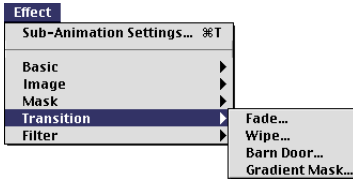
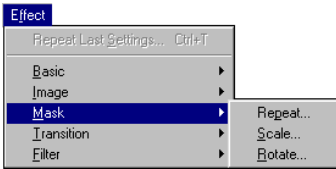

## Mask Effects

Mask Effects (Rotate and Scale) allow you to use the contents of a frame as a mask, and change the size and orientation of the mask gradually between the first and last frame in the cell.

## Transition Effects

Image Effects (Fade, Wipe, Barn Door, Gradient Mask) allow you to create gradual transitions between the first and last frame in the cell.

### Mask Effects—Rotate and Scale

Mask Effects (Rotate and Scale) allow you to specify frame contents as a mask, and to change the size and orientation of the mask gradually between the first and last frame in the cell.

- A** Import/Export: Allows you to import an image into the selected cell or export the selected cell.
- B** Orientation Preview: Displays the current orientation of cell contents. Changes to the Orientation controls affect this Preview. *Note: This is not an animation preview window.*
- C** Orientation Controls: Click the appropriate arrow to change the orientation of cell contents.
- D** Default Fill Pop-up: Select Black or White as the Mask fill color.
- E** Accumulation Pop-up: Select Intersection or Union.
- F** Rotate: Specify "From" Angle and "To" Angle (in degrees), and indicate Clockwise or Counter-clockwise rotation.
- G** Location and Move To Location: Allows you to specify starting and ending locations. (See page 14.)
- H** Preview Controls: Allows you to preview effects without leaving the dialog. (See page 8.)
- I** Cancel: Click to close the dialog box without making any changes to the frame.
- J** OK: Click to Apply the effect and close the dialog box.
- K** Scale Settings: Specify Horizontal and Vertical "From" size "To" size, as a percentage of original size.

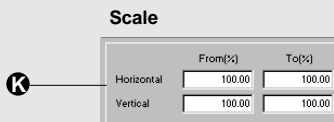
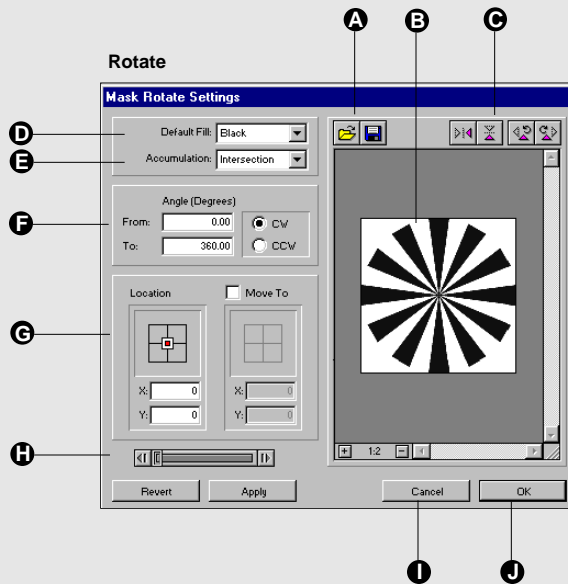

## Transition Effects—Fade, Wipe, Barn Door, Gradient Mask

Transition Effects (Fade, Wipe, Barn Door, Gradient Mask) allow you to create transitions between the first and last frame in the cell.

### Fade, Barn Door, Wipe

- A** Accumulation Pop-up: Select Intersection or Union.
- B** Transition From and To: Specify transition as a percentage of original (0 to 100%).
- C** Transition Settings: Specify orientation, direction, and start-to-end preferences.

### Gradient Mask

- D** Import/Export: Allows you to import an image into the selected cell or export the selected cell.
- E** Orientation Preview: Displays the current orientation of cell contents. Changes to the Orientation controls affect this Preview. *Note: This is not an animation preview window.*
- F** Orientation Controls: Click the appropriate arrow to change the orientation of cell contents.
- G** Direction Pop-up: Select Black to White or White to Black transition.
- H** Mode Pop-up: Select None to All or All to None.
- I** Edge: Changes intensity of mask.
- J** Preview Controls: Allows you to preview effects without leaving the dialog. (See page 8.)
- K** Cancel: Click to close the dialog box without making any changes to the frame.
- L** OK: Click to Apply the effect and close the dialog box.

### Fade

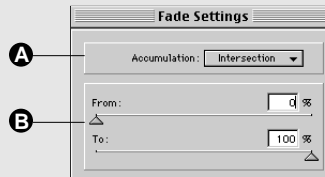

### Wipe

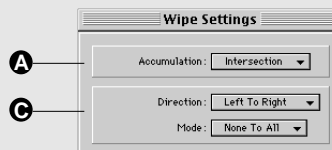

### Barn Door

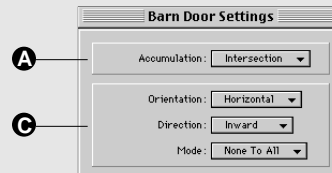

### GradientMask

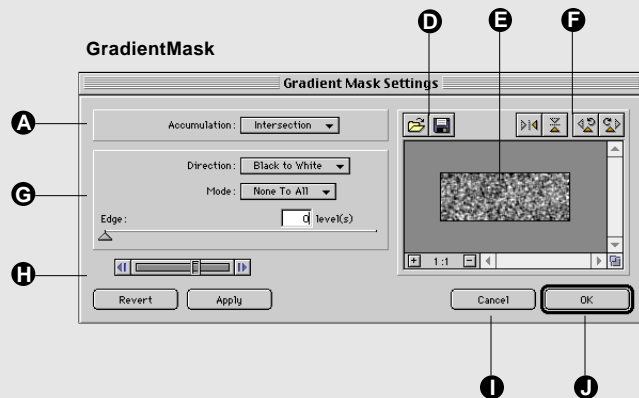



## Tip

You can also Import images by pressing **Command-I [Ctrl+I]**.

## Importing and Import Options

Within PhotoAnimator you can apply limitless special effects to images, but first you must bring those images into the PhotoAnimator program. You do this using the Import command.

You can import any graphic file saved in either Photoshop native format (.psd) or in GIF format (.gif). Imported files can be multi-frame or multi-layer files as well as single frame or single image files.

### Import Options dialog

#### Photoshop File Format (.psd)

- A** Layer Mapping Options: Select from Horizontal Inline (Frames), Horizontal Grouped (Frames), Vertical Grouped (Layers).
- B** Layer Import Direction: Select from Top to Bottom or Bottom to Top.
- C** Import Items: Options are Layer Images, Layer Masks, Composite Image, and Alpha Channels.
- D** Cancel: Cancel the Import operation.
- E** Import: Import the image file using the current selections.

#### GIF File Format (.gif)

- F** Frame Import Method: Select Composite Inline (single layer), Composite Grouped (single layer), or Disassembled (multi-layer)
- G** Include Background Color Layer
- H** Adjust for Frame Delays: Imports additional frames to account for frame delay of imported GIF. For example, if you import a GIF that happens to have a frame rate of 6 Frames per Second, and a particular frame of the GIF was set to delay for 1 second, PhotoAnimator will generate 6 cells to adjust for this delay.

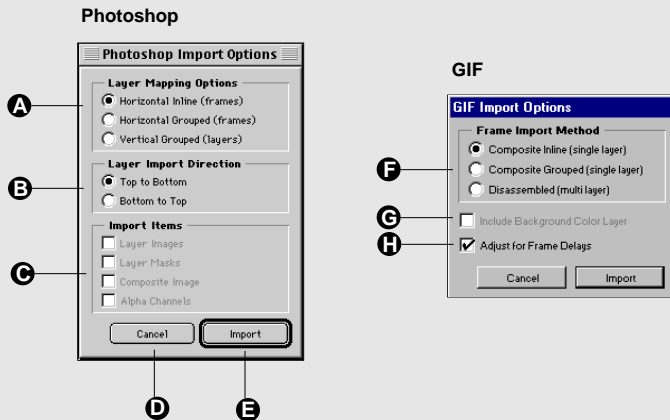

## Exporting and Export Options

### Tip

You can Export your animations by pressing **Command-E** [**Ctrl+E**].

PhotoAnimator animations can be exported as GIF Animations (.gif), as Photoshop layers (.psd), or as PhotoAnimator templates. (For more information on Exporting, see Tutorial 5 starting on page 157.)

Note: Animations can also be saved in the normal way (using the Save and Save As... commands) as PhotoAnimator files (.paf).

### Export Options dialogs

Export Options allow you to save animations in one of three ways: Animated GIF, Photoshop native format, and PhotoAnimator format.

- A** Format: Export options dialog for the Animated GIF format.
- B** Animation Preview: Allows you to preview how the animation will look in with the specified export options applied.
- C** Web Options: Dithering, Color Set, Maximum Colors, Interframe Transparency Option.
- D** Loop Options: Loop Forever, Play (specify number of times).
- E** File Statistics: File Size and Download Time are calculated based on the option settings when Calculate/Preview is initiated.
- F** Calculate/Preview: Click here to apply the indicated settings to the Preview.
- G** Cancel: Close the dialog without applying changes.
- H** Export: Exports the animation in the format indicated at the top of the dialog box, according to the indicated settings.
- I** Player: Allows you to preview the animation as it will appear when exported with the indicated settings.
- J** Preview Zoom: Click "+" to zoom in, click "-" to zoom out.
- K** Photoshop Format: Exports the animation in native Photoshop format.
- L** PhotoAnimator Format: Exports the animation in native PhotoAnimator format. Allows you to create an animation template.

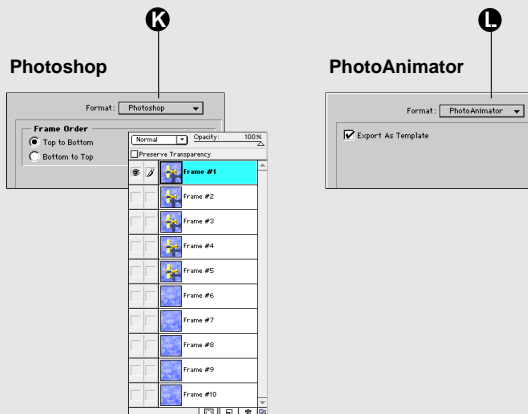
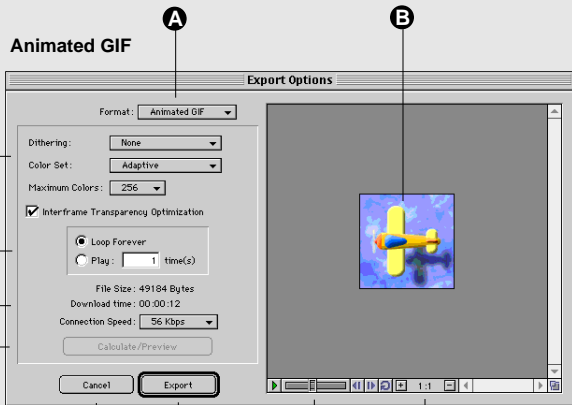

## Preferences



Preferences affect some operations of the PhotoAnimator program.

**Application Start-Up:** Use this preference to specify whether, when launched, PhotoAnimator queries you for a frame size to begin a new animation; presents the system's "Open File" dialog so you can open an existing animation; or simply opens without a document.

**Undo/Redo:** Undo operations require additional memory, so you would want to keep this number low if you have limited system memory. (*Maximum 100 levels of Undo.*)

**Transparency Background:** Select this option to change the color, brightness, and checker-pattern size of the transparency background in the animation Preview window.

### Preferences dialog

- A Application Startup: Controls the PhotoAnimator startup process.  
Do Nothing: Open PhotoAnimator without a document.  
New Document Dialog: When starting PhotoAnimator, present the PhotoAnimator "Frame Size" dialog. (This is the default.)  
Open Document Dialog: When starting PhotoAnimator, present the File System "Open" Dialog.
- B Undo/Redo: Specify maximum levels of Undo/Redo. The larger the number, the more system memory is required.
- C Transparency Checkerboard: Allows you to specify the size and color of the Preview window background checkerboard.
- D Cancel: Close the Preferences dialog without making any changes.
- E OK: Close the Preferences dialog and apply the changes.

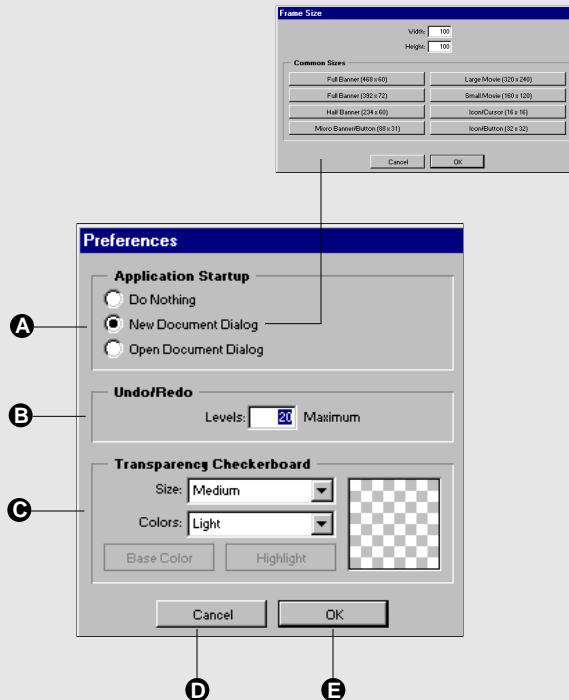

# Tutorial 1: Getting Started—Basic Animations

## Tip

There are five tutorials included in this PhotoAnimator User Guide. To get the most value from the tutorials, we suggest you do them in the order presented. However, it isn't necessary—please use them in whatever way helps you the most.

Having said that, we do encourage you to complete the Airplane Animation (Tutorial 1) first, as it provides an introduction to the basic tools and functions in the application. Tutorials 2 through 5 assume that you have this basic knowledge.

The tutorial sample files referenced in the tutorials can be found in the “Tutorials” folder inside the PhotoAnimator™ 1.0 folder on your hard drive. (For exact file locations, see page 103.)

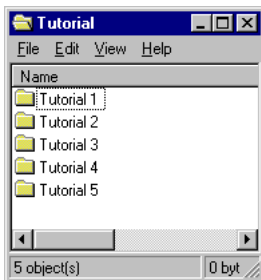

## Tip

You can specify what action PhotoAnimator will take at startup from the Edit > Preferences dialog. Options are: Do Nothing; display New Document dialog; display Open Document dialog.

In this tutorial you will learn how to create a simple animation, while being introduced to the tools and operations available in PhotoAnimator. Once you're familiar with the program, we suggest you check out the rest of the tutorials starting on page 130. These tutorials will introduce you to some of the special effects possible with PhotoAnimator, and hopefully get you started immediately creating fun and eye-catching animations.

## Airplane Animation

We're going to be creating an animation of an airplane flying over a cloudy sky. There are three components to this animation: an airplane, the airplane's shadow, and a cloudy sky.

First we'll make the cloudy background texture scroll seamlessly, then to complete our animation we'll make the airplane and its shadow bounce slightly up and down in relation to one another as if the airplane were encountering some turbulence.

1. **Open the file “airplane\_start.paf” located in the Tutorial 1 folder by double-clicking its icon.** (See page 103 for Tutorial folder location.)

— or —

**Open the PhotoAnimator application, then click “Cancel” to close the New Animation dialog. Select “Open” from the File menu, and locate the “airplane\_start.paf” file.**

At startup, PhotoAnimator (by default) assumes that you want to create a new document and displays the New Animation dialog box. This time we want to open an existing file, so click the Cancel button and open the file from the menu instead.

2. **Familiarize yourself with the PhotoAnimator window.**

The PhotoAnimator window is divided into three panes. The top left pane is called the Layers Pane and functions very similar to the Layers palette found in Adobe Photoshop. This is where you can create, name, hide, delete and reposition layers. *The Layers Pane is described in detail on page 106.*

The top right pane is called the Preview Pane. From this pane you have access to what the animation looks like. The Preview is available at all times in PhotoAnimator, even from the dialog boxes where you apply animation effects.



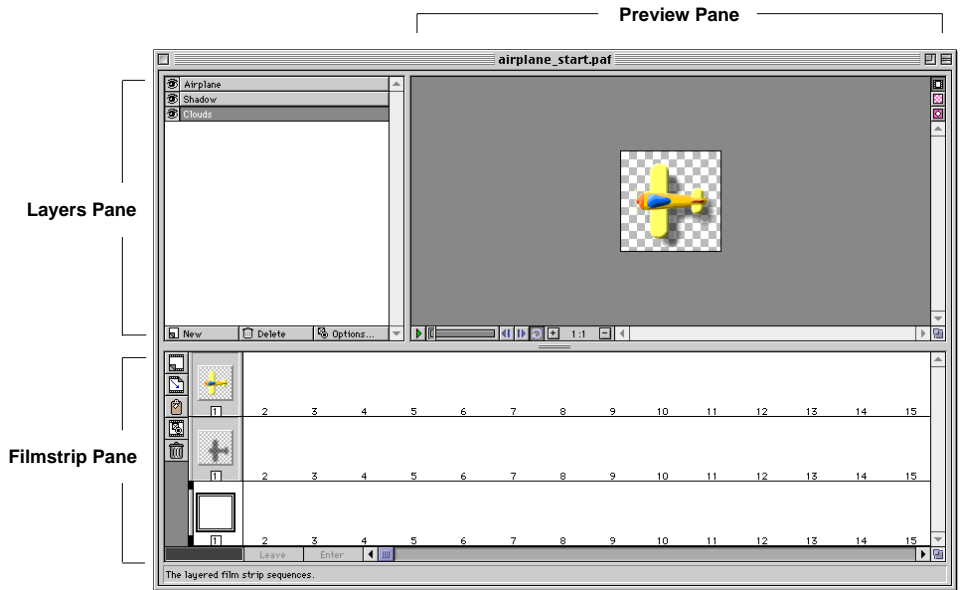

### Tip

To quickly start or stop the animation, press the **Spacebar**.

Use the **Right** and **Left Arrow** keys to move forward and backward one frame at a time.

Use the **Up** and **Down Arrow** keys to move up and down one layer at a time.

### Tip

PhotoAnimator gives you multiple levels of Undo, so don't be afraid to experiment—you can undo as many times as necessary to get back to a known condition.

From the Preview Pane you can play and stop the animation using the animation Player. Press the green arrow to start the animation. When the animation starts the arrow will turn red; press the red arrow to stop the animation. *The Preview Pane is described in detail on page 106.*

The bottom pane of the PhotoAnimator window is the Filmstrip Pane. This is where you will see your animation cells and frames. Each row in the Filmstrip Pane is called a Layer, and the Layers here correspond to the Layers in the Layers Pane above. *The Filmstrip Pane is described in detail on page 107.*

The horizontal divider between the top two panes (Layers and Preview) and the bottom pane (Filmstrip) allows you to adjust the size of the Filmstrip Pane so that you can see more filmstrip rows (layers) at a time. Simply drag the divider up or down. You can also adjust the size of most PhotoAnimator windows and dialog boxes using the grow button on the bottom-right corner of the window.

A Flicker Help Box at the bottom of the PhotoAnimator window displays a brief description of the buttons and functions in the window as you pass the mouse over them.

### 3. Add an image to the animation by Importing it.

Since there will be three elements in the animation, we created three layers—one layer to contain the animation effects for each of the three images. We already imported images into the “Airplane” and “Shadow” layers; now you will bring in the image of the clouds and place it into the “Clouds” layer.

- Click the “Clouds” layer in the Layers Pane to select it, then select “Import” from the File menu.
- Locate the “clouds.psd” file in the “Tutorial 1” folder.

*Note: PhotoAnimator works with only Photoshop native files and GIF images. You can use Photoshop, CorelDraw, or any number of image manipulation programs that can save images in either native Photoshop (.psd) or GIF (.gif) format.*

- On the Import Options dialog, leave the settings as they are (an image of this dialog is shown in the sidebar) and click “Import.”

A clouds texture will be placed in the “Clouds” Layer, and will be displayed in the first frame of the first cell of the last layer (bottom row) in the Filmstrip Pane.

Examine the Filmstrip and Layers Pane. Notice that when you select a layer in the Layers Pane, the corresponding layer in the Filmstrip Pane shows a cell highlighted by a filmstrip icon and a red rectangle. The filmstrip image shows you the selected layer; the red rectangle outlines the currently selected cell; and a black outline around the frame indicates the selected frame.

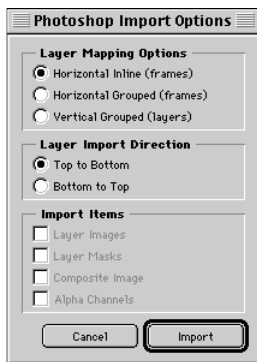
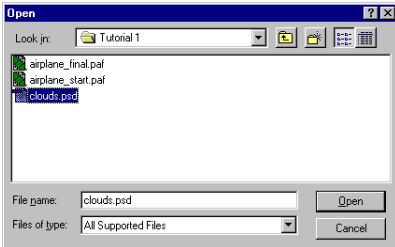

#### Tip

You can also import an image into an existing layer using the Import button on the Filmstrip Pane Toolbar.

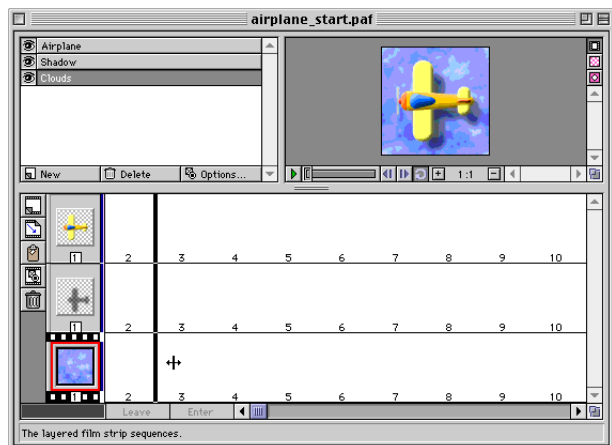

Also notice (in the Filmstrip Pane) that each of our three layers now has one cell, and each cell has one frame in it. Each frame contains one of the imported images.

If you examine the layers in the Filmstrip Pane you'll notice that they are in the same order as the layer names in the Layers Pane. By moving the layer names up and down the layers list you can reorder the layers and dramatically alter our effects.

Don't be too concerned if all this doesn't make a lot of sense right now—the connection between layers, cells, and frames will become more clear as you work on the animation.

#### 4. Now let's extend the clouds texture to make a longer sequence for our animation.

- On the Clouds layer in the Filmstrip Pane, position your mouse on the right edge of the cell border. When the cursor changes to a double arrow, drag this border out just past the position numbered "10."

When you release the mouse you will see that PhotoAnimator has expanded the clouds texture over ten frames automatically.

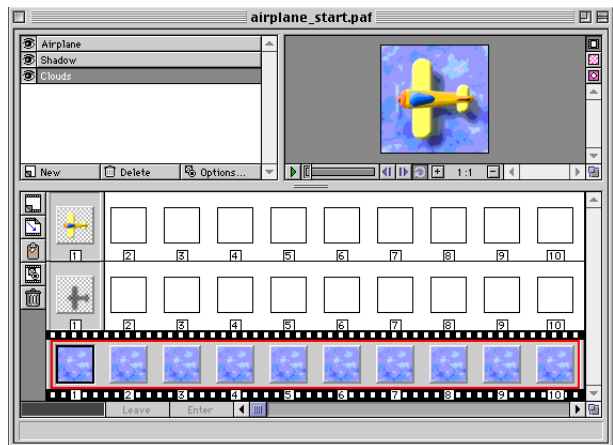
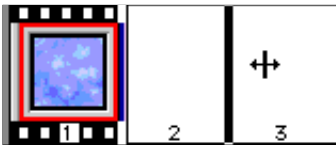

Notice that now the red highlight rectangle includes all ten frames of the clouds texture. PhotoAnimator treats this group of 10 "frames" as one "cell." You can change the number of frames in a cell at any time by dragging its border to a new position.

*Note: You can increase or decrease the number of frames in a cell at any time by dragging the cell's right-hand border.*

*Any Effect Settings applied to the cell will include the newly created frames.*

Click on a few of the frames one at a time and observe what happens in the Preview Pane. If you click on any frame other than the first frame, the airplane and the shadow will disappear. Clicking on frames 2 through 10 in any layer results in the same texture appearing in the Preview Pane.

## 5. Make the clouds appear to move across the sky.

The most important part of creating an animation is applying the special effects that make single-cell graphics look, well... animated! In PhotoAnimator there are a number of different types of effects you can apply to your images, and we'll touch on most of them over the course of these tutorials.

In our first effect, we'll show you how to simulate movement by having the clouds appear to move across the sky.

- **Isolate the cloud layer in the Preview so it will be easier to see the new effect on it: In the Layers Pane, click the eye icon for both the Airplane and Shadow layers so that the eye disappears.**

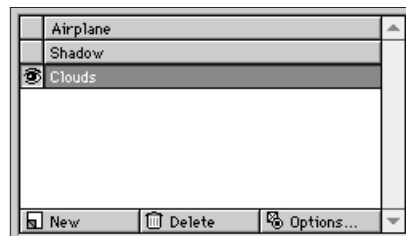

### Tip

To examine or modify the Effect Settings currently applied to a cell, double-click any frame in the cell. Or press **Command+T** (Macintosh) or **Control+T** (Windows).

To change the type of effect applied to the cell, select the new effect from the Effect menu in the menubar.

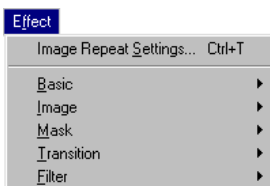

This hides the Airplane and Shadow layers, effectively isolating the Clouds layer.

- **Open the Effect Settings for the clouds texture image: In the Clouds layer of the Filmstrip pane, double-click on any frame in the clouds texture cell.**

This opens the “Image Repeat Settings” dialog box. All Image Settings are Effects (the other Effect categories are: Basic, Mask, Transition, and Filter).

By default, PhotoAnimator applies the Image Repeat Setting to all newly created cells. Image Repeat tells PhotoAnimator to do just that—repeat, or reproduce, the currently selected image in each frame of the cell.

Look carefully at the preview window in the Image Repeat Settings dialog box. Notice that the clouds texture is wider than the texture shown in the Preview on the PhotoAnimator window.

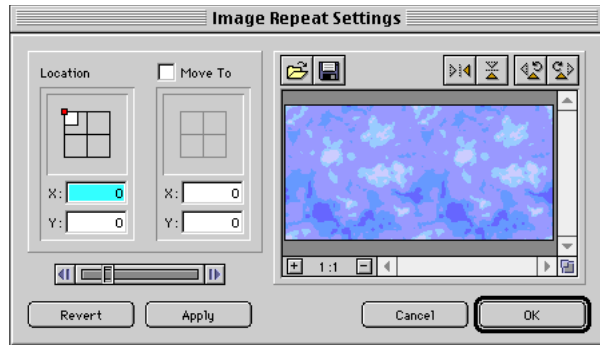

In fact, it is twice as wide. The frame size of this animation is 100 by 100 pixels, but the clouds texture we imported from the clouds.psd file is 100 by 200 pixels. We created the clouds.psd file as a “seamless” texture so that after we animate the texture, it will appear as if the airplane is flying over an endless stretch of clouds.

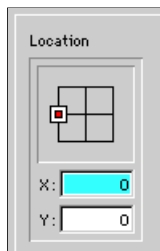

- **Set the start position for the clouds texture: Click on the small white proxy in the upper left corner of the “Location” field and drag it around the grid (both the white and red boxes will move). Position these little boxes over the left center grid point, so that the tiny red box is centered inside the white box.**

The red box sets the proxy, or position point of the image. The white box represents the location of the image. *See page 112 for a more complete description of this feature.*

- Enable the “Move To” option by clicking its box (verify that there is now a checkmark in the box).

The proxies under Move To should now be available.

- Drag the Move To proxies over the right center grid point, keeping the red box centered inside the white box.

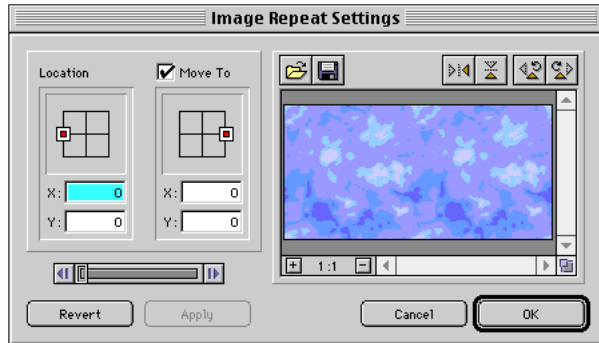

- Move the Image Repeat Settings dialog box so that you can see both the Preview Pane on the PhotoAnimator window and the open Image Repeat Settings dialog.
- In the Image Repeat Settings dialog, click the “Apply” button to temporarily apply the effect to the cell.
- Now drag the slider on the Player in the Image Repeat Settings dialog (its above the Revert and Apply buttons) to the left and right. Watch the Preview.

The cloud texture in the Preview will move back and forth. The movement hasn’t yet been permanently applied to the cloudy texture cell: Clicking the Apply button lets you Preview the effect on the overall animation without actually leaving the dialog box. At this point, if you were unhappy with the results of your effect, you could click the “Revert” button to undo the effect and start over. For now, just leave the effect the way it was.

- When you’ve finished playing with your new effect, verify that the starting and ending locations for the cell frames are as shown above, then click “OK.”

This closes the dialog Effect Settings dialog box and applies the effect to the cell.



- Click the “Loop Playback” button in the Preview Pane.

This puts the Player into continuous play mode.

### Tip

You can toggle the animation Player on and off by pressing the **Spacebar**.



**Click the Play button (the little green arrow) or tap the Spacebar to play the animation.**

If you watch carefully, you will see that the cloudy texture loops seamlessly when the animation plays from the last frame to the first.



**Click the Stop button (the red square) or tap the spacebar again to stop the animation.**

## 6. Now include the airplane and its shadow in the animation.



**Unhide the Airplane layer and the Shadow layer by clicking the Show/Hide box so that the eye icon is visible.**

- **Select the Airplane layer by clicking on it either in the Layers Pane or the Filmstrip Pane.**
- **In the Filmstrip Pane, extend the airplane cell to 10 frames. Repeat this process for shadow cell, expanding it to ten frames as well.**



**Preview the animation by pressing the Play button on the Animation Player. The airplane now appears to be flying over our cloudy sky.**

Not bad so far, but with PhotoAnimator we can easily make our animation more interesting. What you are going to do next is make the airplane appear to bounce up and down as it flies through the air. You will do this by adjusting the scale of the airplane and its shadow over time. When you are done, the airplane will appear to rise and fall. The airplane's shadow will appear to shrink as the airplane rises, and appear to grow as the airplane falls, mimicking how shadows act in the real world.

## 7. Add some additional effects to the airplane, making it appear to encounter turbulence.

You'll need to create another cell of airplane frames for the next effect, and you'll do that by copying and pasting the first cell in the same layer as the original.

- **Copy the five-frame airplane cell: Click in any frame of the cell to select it, then select Edit > Copy. Or use the standard keyboard shortcut [Command+C (Macintosh) or Control+C (Windows)].**
- **Without doing anything else, Paste the cell: Select Edit > Paste, or use the standard keyboard shortcut [Command+V (Macintosh) or Control+V (Windows)].**

### Tip

You can drag-copy a cell to a new location by holding down the **Option** (Macintosh) or **ALT** (Windows) key while dragging.

Notice that the new cell was pasted to the right of the cell that was copied. PhotoAnimator assumes when you copy a cell that you wish to expand the animation of the copied image, and automatically places it in the proper sequence.

- **Repeat this process to create a second cell of the airplane Shadow image on the Shadow layer.**

When you are finished, the Airplane and the Shadow layers should each contain two five-frame cells.

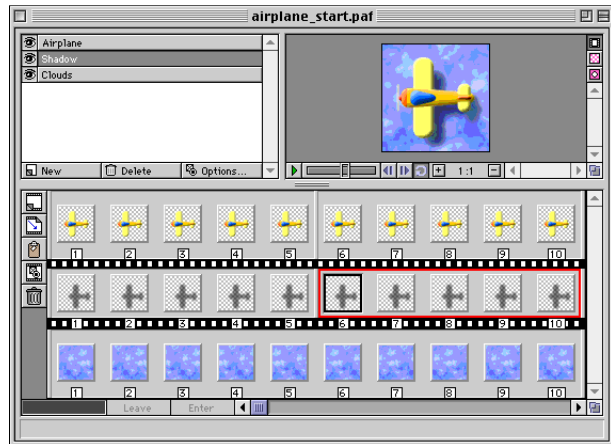

- **Select the first cell on the Airplane filmstrip layer, then select Image > Scale... from the Effects menu.**

This will open the Image Scale Settings dialog box.

Notice that we didn't instruct you to double-click the cell to open the Effect Settings dialog; that's because (as you may recall) the current settings for the cell are "Image Repeat Settings," and you want to apply a different effect to the cell.

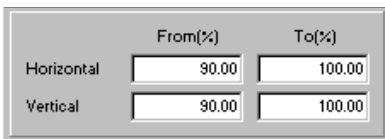

- **In the Image Scale Settings dialog for the first cell, set the Horizontal and Vertical values for the "From(%)" to 90.**
- **Click "OK" to apply the settings and close the dialog.**

- **Now select the *second* cell on the Airplane filmstrip layer, and again select Image > Scale... from the Effects menu.**

This opens the Image Scale Settings dialog for the second airplane cell.

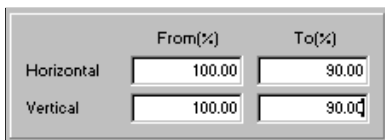

- **Set the Horizontal and Vertical values for the "To(%)" to 90, then click "OK."**





### Now play the animation.

The airplane should appear to bob up and down, while the shadow remains constant.

## 8. The next, and final thing you need to do is animate the airplane's shadow.

- Select the first cell on the Shadow filmstrip layer, then select **Image > Scale...** from the Effects menu.

This will open the Image Scale Settings dialog for the shadow.

- In the Image Scale Settings dialog, drag the proxy to the center of the centerpoint of the Location grid, being sure to center the red box inside the white box.
- Also set the Horizontal and Vertical values for the “To(%)” to 80.

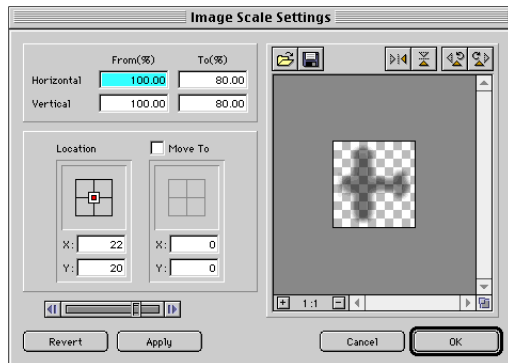

- Click “OK” to apply the settings and close the dialog.
- Select the *second* cell on the Shadow filmstrip layer, then select **Image > Scale...** from the Effects menu.
- In the Image Scale Settings dialog, again drag the proxy to the center of the centerpoint of the grid, being sure to center the red box inside the white box.
- This time, set the Horizontal and Vertical values for the “From(%)” to 80.

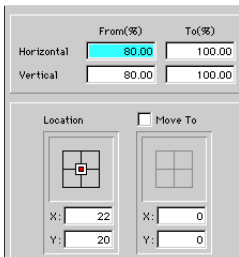

### Play the animation.

Now the shadow appears to shrink away from the airplane as the airplane rises, and expands towards the airplane when the airplane falls.

That completes your first animation in PhotoAnimator. Congratulations—and happy animating!

# Tutorial 2: Working with Masks

### Tip

There are five tutorials included in this PhotoAnimator User Guide. To get the most value from the tutorials, we suggest you do them in the order presented. However, it isn't necessary—please use them in whatever way helps you the most.

Having said that, we do encourage you to complete the Airplane Animation (Tutorial 1) first, as it provides an introduction to the basic tools and functions in the application. Tutorials 2 through 5 assume that you have this basic knowledge.

The tutorial sample files referenced in the tutorials can be found in the "Tutorials" folder inside the PhotoAnimator™ 1.0 folder on your hard drive. (For exact file locations, see page 103.)

In this exercise, you will learn about one of PhotoAnimator's distinctive features—its ability to animate masks in addition to images. This tutorial will focus on the Mask options of PhotoAnimator Effects.

### Mask Effects—The “Click Here Button” Animation

In this tutorial you will create a half-size banner ad. The banner will display the text “What are you waiting for?” for a several seconds. The text will be set on a yellow shape. You will then make the text disappear and use a mask to cut away at the yellow shape, revealing an orange button below the shape that has the words “Click Here” on it. Finally you will make a blue-striped radial graphic rotate around a few times to help accentuate the “Click Here” button.

#### 1. Open the PhotoAnimator application. When the “New Animation” dialog appears, click **Half Banner (234 x 60)**.

The factory default setting is to have the New Animation dialog box appear automatically when PhotoAnimator is launched. If this dialog didn't appear, select File > New. This will give you access to the dialog.

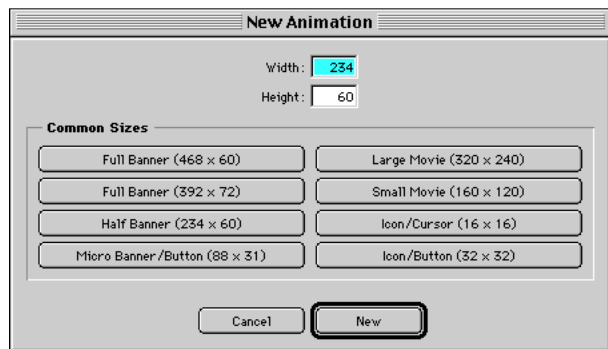

*Note: If the New Animation dialog appears and you wish it didn't, you can change this preference in Edit > Preferences.* PhotoAnimator provides a range of common animation sizes for you to choose from. If a size you need is not listed, you create a custom size simply by entering the dimensions in the Height and Width fields.

### Tip

You can also create a new Layer by pressing **Command+L** (Macintosh) or **Control+L** (Windows).

### Tip

You can also create a New Cell by pressing **Command+K** (Macintosh) or **Control+K** (Windows).

## 2. Create two new layers.



Create a new layer by clicking on the New button in the Layers pane. Name the layer “Spin Mask”.



Create another layer and name it “Light Blue”.

## 3. Expand all three layers out to 30 frames.

- Select the “Background” layer in the Layers Pane. In the  Filmstrip pane, click the New Cell button. This will create a new cell in the Background layer. Drag the cell’s right edge to the right so that the cell contains thirty (30) frames.

You can repeat what you just did to create a thirty frame cell in each of the other two layers, but you’re learning, so let’s do it a different way this time.

- Copy the cell by pressing and holding the Option (Macintosh) or ALT (Windows) key, then drag and drop the cell from the Background layer (in the Filmstrip Pane) into the “Spin Mask” layer.

This places an empty cell 30 frames wide in the Spin Mask layer.

- Repeat for the “Light Blue” layer.

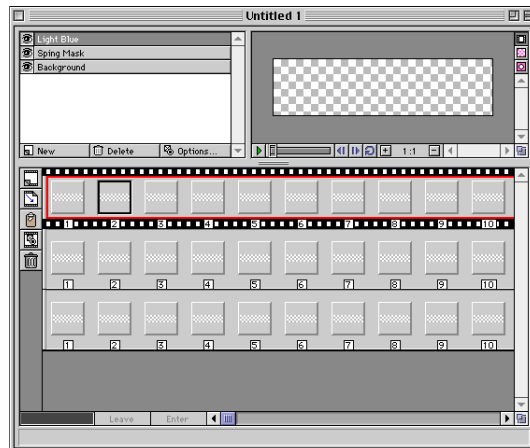

At this point you should have three layers each containing a thirty-frame cell.

4. Now you'll add some color and import a mask to create a nice rotating animation effect.

- Click on the Background layer to select it , then select **Effect > Basic > Solid Color...** from the menubar. Change the RGB values to Red: 0, Green: 0, and Blue: 153, then click OK.
- Repeat this process on the Light Blue layer using RGB values of Red: 0, Green: 153, and Blue: 204.

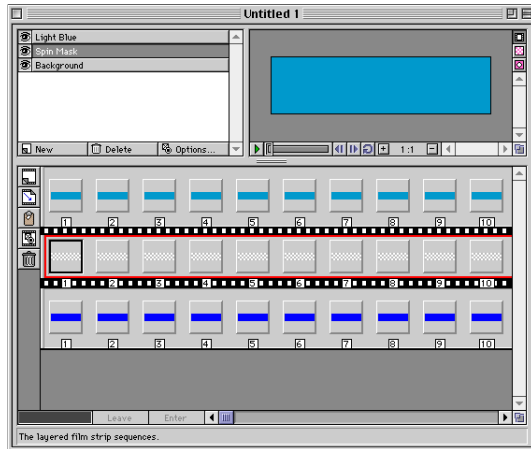
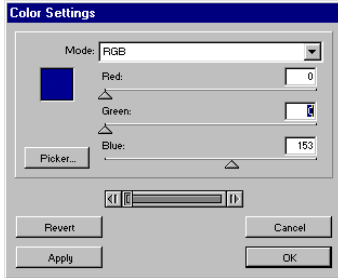

**Tip**

Don't forget that PhotoAnimator provides multiple levels of Undo. Simply press **Command+Z** (Macintosh) or **Control+Z** (Windows) as many times as necessary to "wind back" your actions.

You can Redo an Undo operation with **Command+Y** (Macintosh) or **Control+Y** (Windows).

This creates two layers filled with different shades of blue.

5. Now you'll will mix the two blue layers together and use a Mask to create a radial design between the colors.

- Click on any frame in the Spin Mask layer to select the cell.
- Choose **Effect > Mask > Repeat...** from the menubar.



In the Mask Repeat Settings dialog, click the Open File button and select the "Spinmask.psd" file from the Tutorial 2 folder.

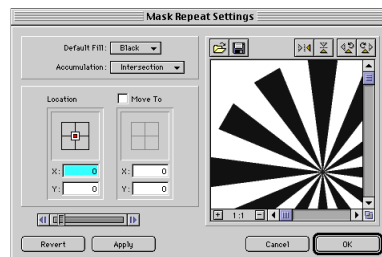
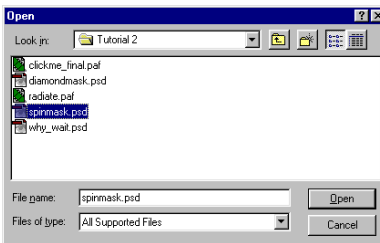

*Note: You may have noticed that the “Spinmask.psd” file is actually much larger than the 234 x 60 size of the animation. This is so that the edge of the mask is never seen in the frame boundaries as it rotates. PhotoAnimator allows you to use masks that are smaller or larger than the animation frame size.*

- Click “OK” to save the mask into the cell and close the dialog box.

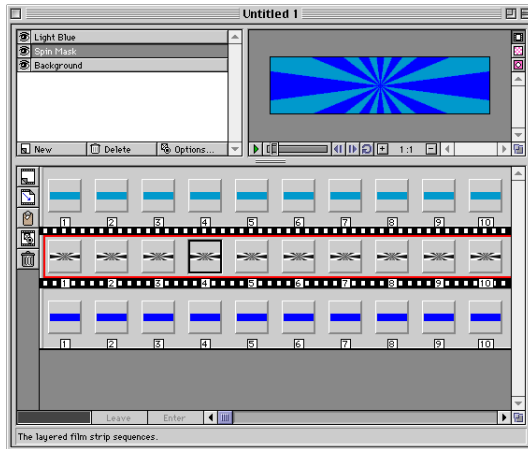

The two colors should now appear to form a radial design. However, if you press the Play button, nothing appears to happen. It’s time to generate some motion!

## 6. Adjust Cell size to prepare for the mask animation.

- Reduce the Spin Mask layer cell size to 24 frames (recall that it is currently 30 frames) by dragging the right border of the cell just past the number 24.

This next step you could do by dragging as you did earlier, but let’s try something new.

- Duplicate the Spin Mask cell, then reduce the new cell to 6 frames: Click in any frame of the Spin Mask cell, then Cut and immediately Paste. Select Animation > Resize Cell from the menubar. Enter “6” in the Number of Frames box.

This duplicates the Spin Mask cell and places the new cell to the right of the copied cell, and reduces the size of the new cell from 24 to 6 frames.

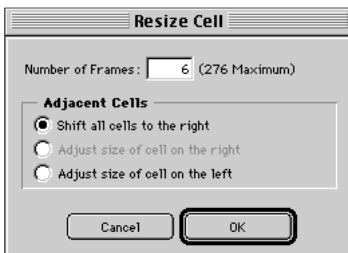
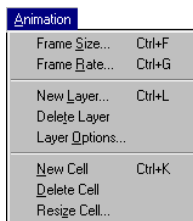

### Tip

When you copy and paste a cell in PhotoAnimator, the pasted contents are added to the right of the currently selected cell.

The Spin Mask layer should contain two cells. The first cell should be 24 frames long, and the second 6 frames long. Each cell should contain the same mask that we imported in step 5.

### 7. Create a short spinning effect for the Mask.

- In the Filmstrip Pane, click any frame in the second cell of the Spin Mask layer (the cell with 6 frames) to select it.
- Select **Effects > Mask > Rotate...** from the menubar. Enter the following values:  
**From: 0° To: 50° Clockwise (CW)**
- When you have finished entering the Mask Rotate effect settings, click “OK” to apply the settings and close the dialog.

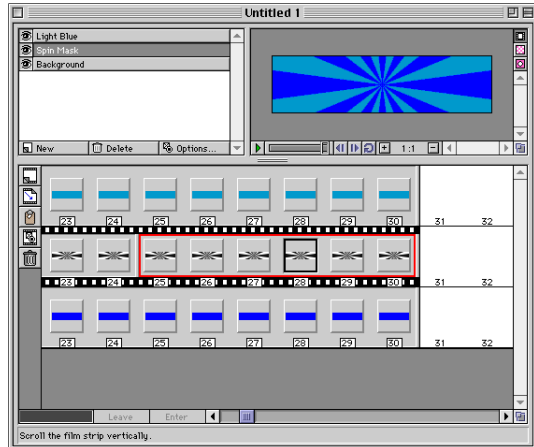

**Preview the animation by pressing the Play button in the Preview Pane. Now the blue-striped radial design should stay static for a few seconds and then rotate a few times. If you turn on the Loop button in the Preview Pane you will notice that the rotation loops seamlessly.**

Up to this point you have been working on the background for the animation. Now you are going to add in all of the other elements.

8. Create five new layers to hold the rest of the animation elements.

- Select the Light Blue layer in the Layers Pane.

You select this layer because you want your new layers to be positioned above this one, and PhotoAnimator inserts new layers above the selected layer.

- Create five new layers and name them in exactly this order: “Border,” “Click Here,” “Diamond Mask,” “Shield,” and “What Are You Waiting For.” (“What Are You Waiting For” should be the last and top layer.)

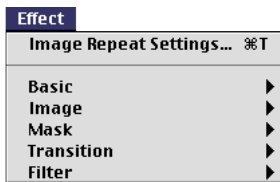

When you are finished you should have eight layers listed in the Layers Pane, and each layer should have a unique name.

9. Import and examine a multi-layer file (“why\_wait.psd”).

- Click on the Border layer in the Layers Pane and choose Import from the File menu, or press Command+I (Macintosh) or Control+I (Windows) .

- In the Open dialog box, select the “why\_wait.psd” file from the Tutorial 2 folder.

- When you’ve located the “why\_wait.psd” image, click “OK.”

The Import Options dialog will be displayed.

- Verify that the options in the Photoshop Import Options dialog are at their default settings: Horizontal Inline (frames); Top to Bottom; and all the Import Items boxes unchecked.

- Click “Import.”

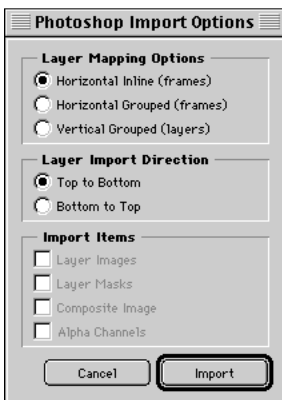

There are four images in the “why\_wait.psd” file. Notice that after you imported the file, four cells were added to the Border layer. Each cell corresponds to a separate layer in the file you just imported.

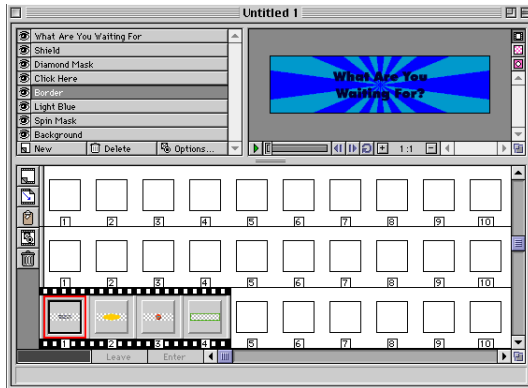

You must now move each of these images onto their own layer.

### 10. Move each of the imported images from the Border layer to the appropriate layer.



Since the new images in the cells are very small, click the Checkerboard icon in the Preview Pane. This will isolate the Preview to just the contents of the selected frame, which will allow you to easily identify each element.

- To help you see the target Filmstrip layers where you’ll be dragging the new cells, enlarge the window as much as you can.

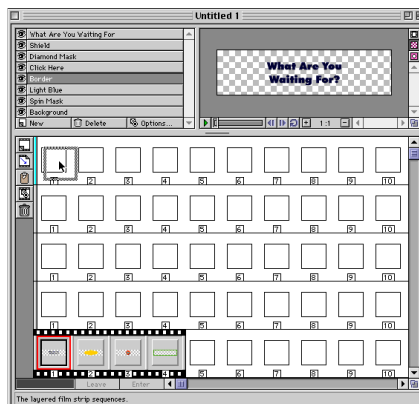





**Tip**

To quickly determine which layer an image has been placed in, click the image. This selects the layer, causing the layer name in the Layer Pane list to be highlighted. Scroll the list, if necessary, to bring the selected layer name into view.

**Tip**

You can automatically create a new cell in an empty layer and size the cell at the same time. Simply drag the empty cell border to the right until you've created as many frames as you need. New frames will be created as you go along.

**Tip**

You can toggle the animation Player on and off by pressing the **Spacebar**.

- Click and drag the first cell (it should be the “What Are You Waiting For?” image) into the “What Are You Waiting For layer.” This will be the top layer in the Filmstrip Pane.
- The next image should be the yellow shield. Click and drag this image to the “Shield” layer. The Shield layer is second from the top.
- Locate the “Click Here” button and drag it to the “Click Here” layer.
- The remaining cell in the Border layer should display a green border image. Leave this cell where it is.

Note that you still have one empty layer, the layer named “Diamond Mask.” We will be tending to this omission shortly.



Since you have finished moving the cells around, you can restore the composite (multi-layer) Preview in the PhotoAnimator window by clicking the Show Composite



button at the top of the Preview Pane.

**11. Resize the Border, Shield, and Click Here layers to be 30 frames wide.**

- Click any frame in the Border layer cell, then select **Animation > Resize Cell....** When the dialog box opens, enter **30** in the **Number of Frames** box.
- Repeat this step for the Click Here and Shield layers.

**12. Resize the Diamond Mask and What Are You Waiting For layers to be 15 frames wide.**

- Select the Diamond Mask layer, then create a new cell in it by clicking on the **New Cell** icon in the Filmstrip Pane. Resize this cell so it has 15 frames in it.
- Resize the cell in the What are You Waiting For layer to 15 frames as well.



Click the **Play** button in the Preview Pane. The message

“What are you waiting for?” should display for 15 frames and then disappear.

Now you will use a Mask to make a diamond-shaped hole appear on the yellow shield, which will reveal the “Click Here” button for several frames.

### 13. Import the last image and apply its special effect.

- Select the cell in the “Diamond Mask” layer.
- Copy and Paste the cell to create a duplicate cell to the right of it. Resize this duplicated cell from 15 frames to 9 frames (the second cell will end at the Frame 24 marker).
- Verify that this second cell (Frames 16 through 24) is selected (red border around it), then select **Effect > Mask > Scale...** from the menubar.



Click the Open File button in the Mask Scale Settings dialog box and select “Diamondmask.psd” from the Tutorial 2 folder, then click Import.

You may want to scroll the Settings preview in order to see the diamond mask. It isn’t necessary to see it, however—if you imported it, it’s there!

- Enter the following effect settings:

**Default Fill:** White

**Accumulation:** Intersection

**Horizontal and Vertical “From(%)”:** 0 (zero)

**Horizontal and Vertical “To(%)”:** 100

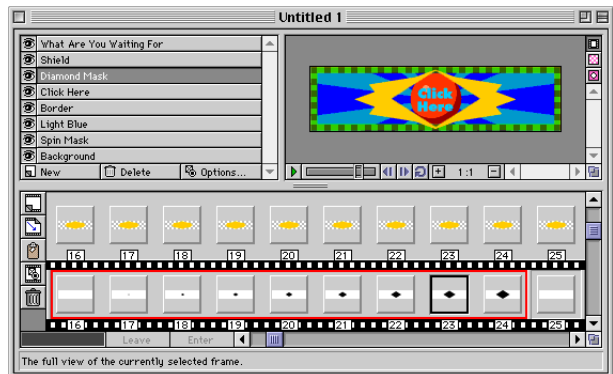
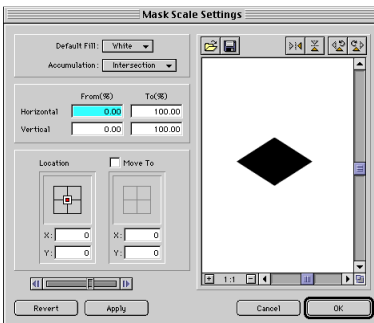

- Click “OK” to Apply the effect and close the dialog.

Preview the animation.

A diamond-shaped hole should appear in the yellow shield between Frames 16 and 24. However, after Frame 24, the shield goes back to fully covering the “Click Here” button. Let’s change that.

Default Fill:	White	
Accumulation:	Intersection	
	From(%)	To(%)
Horizontal	100.00	100.00
Vertical	100.00	100.00

#### 14. Add another cell to fine-tune the animation.

- **Copy and Paste the second cell on the Diamond Mask layer.**

This creates a third cell on the Diamond Mask layer.

- **Resize the newly pasted cell so that it contains 6 frames (this third cell will end at the Frame Number 30 marker).**



- **Double-click anywhere in this cell to open the Mask Scale Settings dialog box.**



- **Change the Horizontal and Vertical “From(%)” values to 100, then click “OK.”**

**Verify that the “Loop” button is pressed so the animation will play continuously.**

#### **Play the animation.**

The final animation should display the text “What are you waiting for?” for a few seconds. Then the text should disappear and a diamond-shaped hole should get larger and larger until the “Click Here” Button is fully visible. The “Click Here” button should remain visible for six frames. Finally, the radial blue strips should rotate a few times, then the animation should start over.

That completes the “Click Here Button” animation, but before you wrap up your work with Masks, let’s look at some layered masking effects.

## Layered Masks—The “Radiation” Animation

This example demonstrates that you can combine masks on different layers to create interesting animation effects. In the next tutorial (Tutorial 3) you will learn how to make and use Gradient Masks—a unique and powerful PhotoAnimator effect tool that gives you more creative capability than any animation program of its type.

### 1. Open the “Radiation” animation.

- Select **File > Open...** from the menubar.
- Locate the “Radiate.paf” file located in the **Tutorial 2** folder on the **Extensis CD**.
- Click “**OK**” to open the animation file.

Notice that you can store PhotoAnimator files in PhotoAnimator’s own proprietary format (.paf). This allows you to save animations without exporting them. You can also import “.paf” files into PhotoAnimator—we’ll talk about import and export options in our final tutorial “Exporting Animated GIFs” starting on *page 157*.

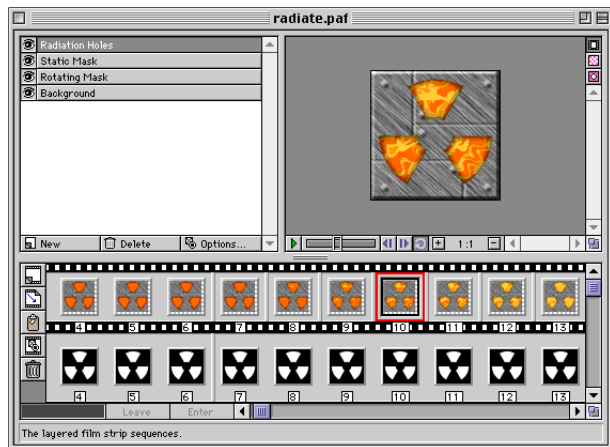

### 2. Play the animation and observe the animation effect.

The holes that form a classic radiation symbol gradually open up to reveal an orange-colored backdrop. Then a wild transition occurs between orange and yellow (this effect was achieved with a Gradient Mask transition which will be covered in the next tutorial). Finally, the radiation holes close back up again.

We created the opening and closing of the radiation holes by layering two masks. The first mask, on the “Static Mask” layer, is stationary. The second mask, on the “Rotating Mask” layer, employs the same mask that was used on the Static Mask layer. However, the mask on the Rotating Mask layer rotates. When the second mask layer rotates relative to the first, the holes of the radiation appear to open and close.

In the next tutorial (Tutorial 3), you will learn about Transitions and see how to use a Gradient Mask—a unique and powerful animation tool unique to PhotoAnimator.

# Tutorial 3: Working with Transitions and Gradient Masks

## Tip

Don't forget that PhotoAnimator provides multiple levels of Undo. Simply press **Command-Z [Ctrl+Z]** as many times as necessary to “wind back” your actions.

You can Redo an undo operation with **Command-Y [Ctrl+Y]**.

In this exercise, you will learn about another one of PhotoAnimator's distinctive features—its ability to produce simple to complex transition effects. This tutorial will focus on the Transition options of PhotoAnimator Effects.

## Barn Door and Dissolve—The “Web Button” Animation

PhotoAnimator makes it easy to apply transition effects to cells. Basic transitions such as wipes, fades, and “barn door” transitions are directly supported using the dedicated Effects commands.

PhotoAnimator compliments these “bread and butter” transition effects with a feature called “Gradient Mask.” The Gradient Mask feature uses a mask saved as a Photoshop (.psd) or GIF (.gif) file to create any number of unique transition effects.

There are three exercises in this tutorial:

- In the first exercise, you will learn how to create basic transition effects such as a Barn Door transition.
- In the second exercise, you will learn how to create a Gradient Mask transition.
- In the third exercise, you will look at a ready-made example file to see just how dynamic and complex Gradient Mask transitions can be.

## Barn Door and Dissolve Transitions

In this tutorial you will add animation to a simple Web button. The button will grow into view using the Barn Door transition. A glow that temporarily highlights the button will fade in and out of view. And finally, when the button is fully visible, the word “Extensis” will dissolve into view over the button. You will accomplish all of this with transition effects.

### 1. Preview the “button\_start.paf” animation.

- Open the “button\_start.paf” file located in the Tutorial 3 folder.



**Play the animation to get an idea of what it looks like before you start changing the effects.**

A blue-green glow appears around a button. After a few seconds the glow disappears and the word “Extensis” appears.

*Note: The glow is actually blue, but appears blue-green when viewed around a green button and against a yellow background. Since the visible effect is blue-green, we'll be referring to it that way.*



button\_start.paf

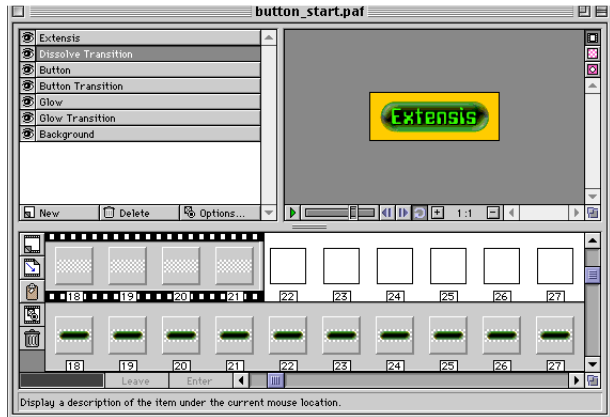

This PhotoAnimator File (.paf) contains seven layers. All of the layers are set up with cells, images, and effects already in place so that you can start right in working with transitions.

There are three of the layers in the Layers Pane that contain the word “Transition” (Glow Transition, Button Transition, and Dissolve Transition). Each of these layers already contain the blank cells that you will use to create the transition effects.

**Transition cell placement:** A transition cell will affect the content cell directly above it. Notice in this sample file that we have placed each transition layer directly below the content layer that the transition will be applied to.

## 2. Begin by creating a transition between the Glow and Background layers.

- Select the Glow Transition layer in the Layers Pane, then click any frame in the first cell of the Glow Transition layer in the Filmstrip pane.

*Note: You don't need to select a layer in the Layers Pane in order to select a cell in that layer in the Filmstrip Pane, but doing so makes it easier to locate the right Filmstrip layer.*

- Select Effect > Transition > Barn Door from the menubar.
- Select the following Barn Door Settings:

**Accumulation: Intersection**  
**Orientation: Vertical**  
**Direction: Outward**  
**Mode: None to All**

- When you have completed the settings, click “OK.”

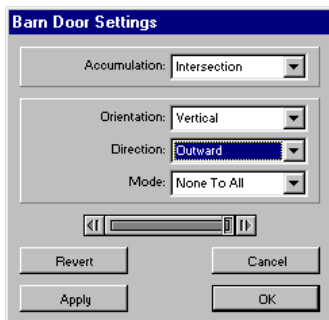



### Preview the animation.

Notice that the blue-green glow appears to grow around the button shape in a vertical progression over the first eight frames of the animation.

### 3. Now you'll make the glow disappear out of view using a slight variation of the Barn Door transition.

- Click on any frame in the second cell on the Glow Transition layer.
- Select Effect > Transition > Barn Door from the menubar.
- Select the following Barn Door Settings:

**Accumulation: Intersection**  
**Orientation: Horizontal**  
**Direction: Inward**  
**Mode: None to All**

- When you finish with the settings, click "OK."

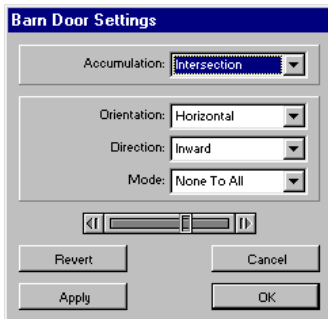

### Preview the animation again.

First the blue-green glow transitions into full view under the direction of the vertical Barn Door wipe, then disappears. It next appears horizontally, transitioning into full view under the direction of the horizontal Barn Door wipe, then disappears.

### 4. Next you'll create a transition so that the button fades into view after being hidden at the start of the animation.

- Select the Button Transition layer in the Layers Pane.

Since there is only one cell in this layer, the cell is automatically selected when you select the layer.

- Once again select Effect > Transition > Barn Door from the menubar.
- Select the following Barn Door Settings:

**Accumulation: Intersection**  
**Orientation: Horizontal**  
**Direction: Outward**  
**Mode: None to All**

- When you have completed the settings, click "OK."

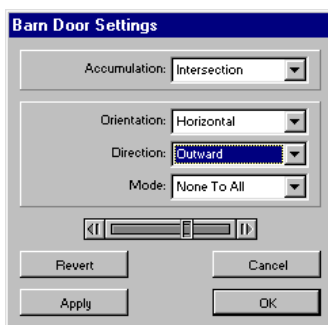

### Preview the animation once again

This time the button fades into view horizontally while the blue glow appears around the button for several frames and then disappears.



5. For our last Web Button animation effect you will use a Gradient Mask transition.
  - Select the Dissolve Transition layer in the Layers Pane.
  - Click on any frame in the *second cell* of the Dissolve Transition Filmstrip layer (the first cell will not have an effect applied to it and will act as a place-holder).
  - Select Effect > Transition > Gradient Mask.



Click on the Open file button in the Gradient Mask Settings dialog box and select “dissolve.psd” from the Tutorial 3 folder.

This places a texture in the second cell of the Dissolve Transition layer that you will use as a gradient mask.

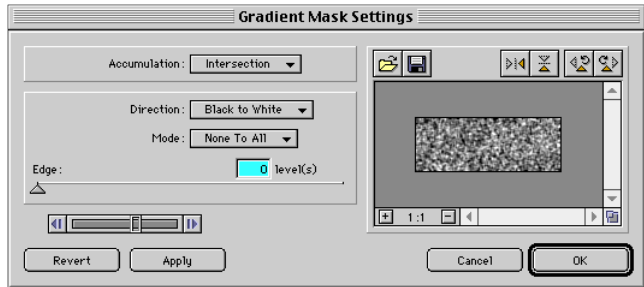

- Select the following Gradient Mask Settings:
  - Accumulation: Intersection**
  - Direction: Black to White**
  - Mode: None to All**
  - Edge Levels: 0**

### Tip

The Player always starts an animation with the currently selected frame. You can of course start the animation at the first frame by dragging the Player slider all the way to the left. Another way is to press the Home key.

The **Home** key takes you to the first frame in the selected layer. The **End** key takes you to the end of the animation in the current layer (even if the frame is empty).

You can set the Edge levels value to 0 by either entering the number zero in the levels field or by dragging the Edge slider to the far left. If you are wondering what Levels does, don't worry we'll talk about Levels soon.

- Click “OK.”



**Preview the animation.**

With our new settings, after the Button and Glow Transitions perform their respective effects, the Button stays fully visible and the word “Extensis” dissolves into view, the result of using the Gradient Mask.

As you can see, the Gradient Mask effect is more sophisticated than the simple Barn Door transition. This Dissolve effect is just one of the infinite types of transitions that the

Gradient Mask feature is capable of making. Let's look at how Gradient Mask transitions work.

**Gradient Mask Transitions:** Gradient Mask effects use an image as a mask to create the effect. As mentioned, this mask can be a GIF (.gif) or a Photoshop format (.psd) file. The Photoshop file can be an RGB, Grayscale, Indexed, or Duotone image, but you cannot use Photoshop files that are in LAB or CMYK color mode. Mask files do not need to be the same size as the animation.

PhotoAnimator's Gradient Mask Transition effect uses the brightness values of the pixels in the mask file to create its effect. Although you can use RGB, Duotone, or Indexed color files as masks, for optimal results it is best to stick with Grayscale images because PhotoAnimator will actually convert other color formats to Grayscale anyway.

- **Double-click any frame in the second cell of the Dissolve Transition layer.**

Recall from Tutorial 1 that once a cell has had an Effect applied to it, double-clicking any frame in the cell automatically opens the Effect Settings dialog box for that effect. In this case, the Gradient Mask Settings dialog will open, since that was the Effect last applied to this cell.

- **In the Gradient Mask Settings dialog box, drag the Edge slider to the right until the Levels field reads 130.**

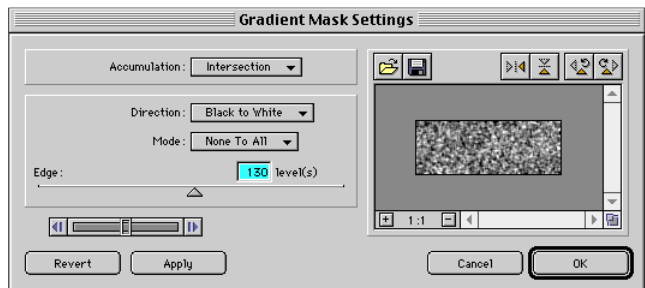

The Levels control in the Gradient Mask Settings dialog controls the transition “fuzziness.” Transitions created with the Gradient Mask feature can look very different depending on the Levels setting.

- **Click “Apply.”**

(Recall that the Apply button only temporarily applies the parameters in a given settings dialog box, allowing you to Preview different settings before committing to them.)

- **Move the Gradient Mask Settings dialog so that you can see the Preview Pane and the Gradient Mask Settings dialog at the same time.**
- **Move the Player slider in the Settings dialog (its located above the Revert and Apply buttons) back and forth and observe the change in the animation Preview Pane.**

If you look carefully, you’ll see that the dissolve effect has been blurred by the new Levels setting of 130.

If you move the Edge slider back to the far left (0) and preview the animation again, you will see that the Edge Effect is very pixelated—which is probably more appropriate for this dissolve effect than the 130 Level you just looked at.

So you can see that with the Gradient Mask Effect you can create a wide range of transition effects with any given mask file, creating an unlimited number of possibilities. In the next exercise you will examine another file to see a few more of the many creative opportunities available with this unique effect.



**Tip**

PhotoAnimator allows you to have multiple files open at the same time. This can be quite handy for comparing effects.

For example, you might set different effect values for the same cell in each of two otherwise identical PhotoAnimator (.paf) files. You’d put each animation Player in Loop mode, and Play back both animations. Then just sit back and watch the two playing side-by-side!

## Complex Animations with Gradient Masks—The Aperture Animation

In this exercise you will look at a file with lots of Gradient Transitions to get an idea of the creative possibilities.

### 1. Examine the Aperture.paf animation.

- Open the “aperture.paf” file located in the Tutorial 3 folder.



Verify that the Loop button in the Preview Pane is pressed so that the animation will play continuously.



Play the animation.

An aperture opens up to reveal a sort of radial explosion effect, and then the aperture closes again.

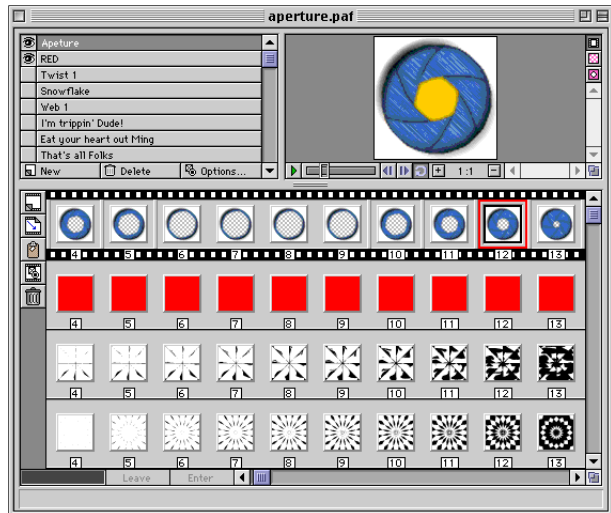

Notice that there are numerous invisible layers (layers with their eye icon turned off) in the Layers Pane. This file was created to show you a variety of Gradient Mask transitions. You will hide and reveal different layers so that you can better view these different transition effects.

### 2. Hide the Aperture layer and examine the effect.



In the Layers Pane, hide the Aperture layer by clicking on its eye icon (the eye should disappear indicating that the layer is hidden).

All of the layers are actually Gradient Masks except the Aperture, RED and YELLOW layers. The RED and YELLOW layers are filled with solid colors (Effect > Image > Solid Color). Using solid colors as the background for a Gradient Mask is a often a great way to set off the effect.

Notice that only four layers are currently visible: the “YELLOW,” “Diagonal 1,” “Concentric,” and “RED” layers.



**Preview the animation again, and notice the combined effects of the “Diagonal 1” and “Concentric” Gradient Mask layers on the “YELLOW” and the “RED” layers.**

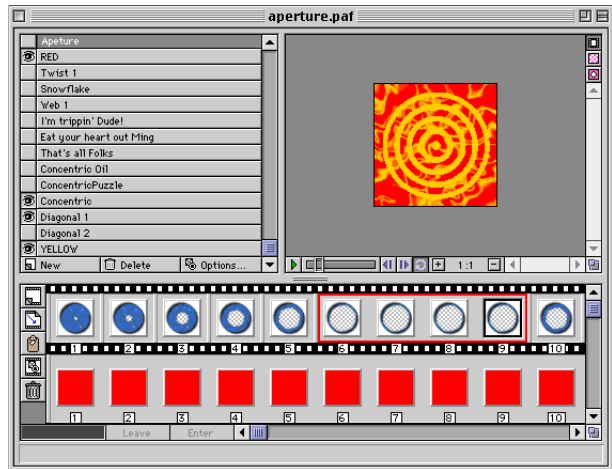

**Hide the “Concentric” layer and then Preview the animation again.**



**Now hide the “Diagonal 1” layer and turn the “Concentric” layer back on.**



**Preview the animation again.**

As you can see, the effects of these Gradient Mask layers are very different. Take a moment now and turn on and off various Gradient Mask layers and observe the results by previewing the animation. Try different combinations. After a while you will begin to appreciate the incredible range of possibilities with Gradient Mask transitions.

4. Now let's look at a few of the mask files used to create some of these Gradient Masks transitions.



First, unhide the “Twist 1” layer.

- Next, double-click on any frame in the *second* cell of the Twist1 Filmstrip layer to open up the Gradient Mask Settings dialog.

The Preview window in the Gradient Mask Settings dialog shows the file used as the mask for this layer. This mask, like most of the mask files in this example animation file, was created in Photoshop using Filter Factory filters (most of these filters are available for free on the Web).

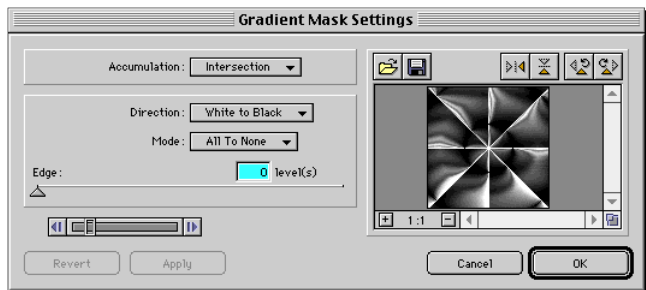

- Zoom in on the mask by clicking on the Plus (+) sign in the Preview window of the Gradient Mask Settings dialog.
- Roll your mouse cursor over this Preview window. When the cursor changes to the hand icon, click and drag to observe the detail of the mask.

Notice that the mask has a broad range of gray values. In general, the more gray values there are in a mask, the more versatile the mask is. This is because the Gradient Mask Transition effect uses the brightness values of each pixel to create the transition effect over time. A mask with a large variety of gray values in it gives the Gradient Mask Transition more options.

## Tips for Creating Masks Suitable for the Gradient Mask Transition Effect

While you can generate a mask in any program that will export to GIF or PSD format, for this exercise we will assume that you are working in Photoshop.

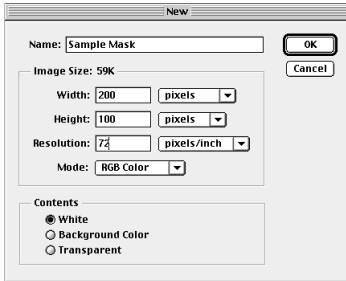

- **Launch Photoshop and open a new file.**

You generally want to start with a file size that is the same or approximately the same as the animation that you will use the mask in. You will also want to select RGB mode, since many of Photoshop's filters and features aren't available in Grayscale mode.

- **Press the letter "D" on your keyboard to ensure that the foreground and background colors are set to black and white respectively.**
- **Select a filter or line art to use as a base for the mask, then add your own special effects.**

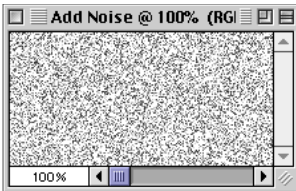

A great place to start is with the Filter > Noise > Add Noise (with the Monochrome setting on) filter, or Filter > Render > Difference Clouds filter. These filters create random textures that you can use as starting points for your masks. You can also start with any line art or patterns that you may have. Simply convert the line art or patterns to gray values with the Image > Adjust > Desaturate feature.

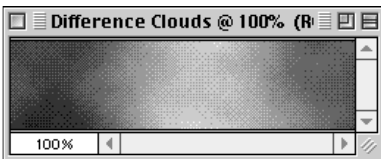

Once you have a basic foundation, try any variety of filters. Our advice is for you to go wild. Just about anything will work. However, some of the more simple effects might generate more practical results. For example, the mask used to generate the dissolving text effect in the earlier example was created with the Add Noise and Blur More filters.

Another way to go is to apply a basic black to white gradient. Try diagonal gradients or radial gradients. If you have a solid line art shape like an ellipse, try applying Gaussian Blur with a high setting to create in essence a custom gradient.

PhotoAnimator's Transition effects offer a wide range of possibilities for animation. The potential variety offered with the Gradient Mask transition effect is endless. Especially since you can combine multiple Gradient Masks, not to mention all of the other effects found in the Effects menu in PhotoAnimator. You are limited only by your imagination. Have fun!

# Tutorial 4: Working with Nested Sub-Animations

PhotoAnimator allows you to nest animations within a cell and then apply effects to them much like you would to any other cell. In this tutorial you will quickly create and use nested sub-animations.

## Nested Sub-Animations—The Hectic Animation



### 1. Preview the “hectic\_final.paf” animation.

- Open the “hectic\_final.paf” file located in the Tutorial 4 folder.



Play the animation several times to get an idea of the different animations that are a part of it.

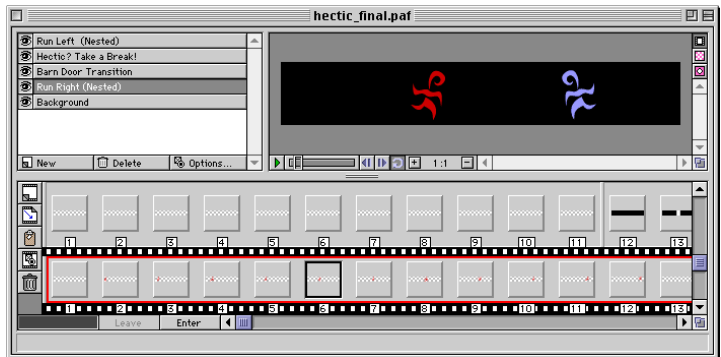

### Tip

Don't forget that PhotoAnimator provides multiple levels of Undo. Simply press **Command-Z [Ctrl+Z]** as many times as necessary to “wind back” your actions.

You can Redo an undo operation with **Command+Y [Control+Y]**.

Notice that this animation consists of five layers: “Run Left (Nested),” “Hectic? Take a Break!,” “Barn Door Transition,” “Run Right (Nested)” and “Background.” The two layers that are labeled with (Nested) contain animated animations, or what PhotoAnimator calls Nested Sub-Animations.

- Click “Run Right (Nested)” layer in the Layers Pane.

This layer contains one 14-frame cell. Notice that when you select this cell the “Enter” button below the Filmstrip Pane becomes active.



Click the Enter button.



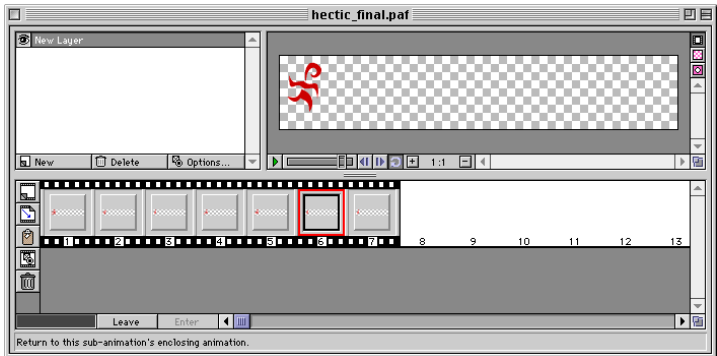

When you click on the Enter button PhotoAnimator takes you into a Nested Sub-Animation work area. The Nested Sub-Animation Window behaves exactly like it does with regular animations in PhotoAnimator: You can work with layers on the Layer Pane, preview the Nested Sub-Animation in the Preview Pane, and work with frames and cells in the Filmstrip Pane, just as you can with a normal animation.



#### **Preview the Nested animation.**

This nested animation consists of a simple loop of a stylized running stick figure. Notice that the stick figure is running in a stationary position. As you will soon see, the advantage of using a Sub-Animation is that you can apply movement to it externally. In other words, you can move, rotate, resize or otherwise apply any of PhotoAnimator’s effects to a nested animation. This means that you can easily make adjustments to the movements of the sub-animation.

More importantly, your nested sub-animations can have the same characteristics as normal layers. This means that your nested animations can move wherever you want them to and you don’t have to worry about anti-aliasing to other imagery in the animation. PhotoAnimator takes care of that for you when you export.

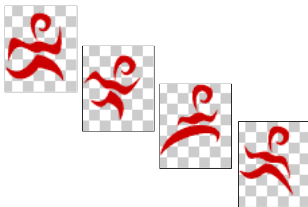

**Click the Leave button, then close the “hectic\_final.paf” file without saving changes.**

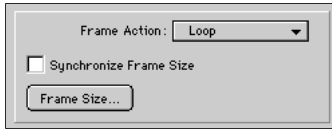

2. Open the “hectic\_start.paf” file located in the Tutorial 4 folder.

- Select the “Run Left (Nested)” layer and create a new cell on this layer. Resize the cell to 32 frames.
- Select Effect > Basic > Sub-Animation... from the menubar.
- Select Loop from the Frame Action pop-up menu, then click “OK.”



Click the Enter button at the bottom of the Filmstrip Pane to open the Nested Sub-Animation work area.



Click on the empty cell on the Filmstrip Pane, then click the Trash icon, or press the Delete key on your keyboard.

You’re going to import a file with multiple graphics, so you first needed to delete the existing cell.



Click the Import button.

- Locate the “run\_left.psd” file in the Tutorial 4 folder, then click “Open.”

The Photoshop Import Options dialog box will be displayed.

- In the Photoshop Import Options dialog box, set the Layer Wrapping Options to “Horizontal Inline (frames)” and set Layer Import Direction to “Top to Bottom.”
- Click “Import” to import the image file.

**Tip**

To Import an image file, press **Command-I [Ctrl+I]**.

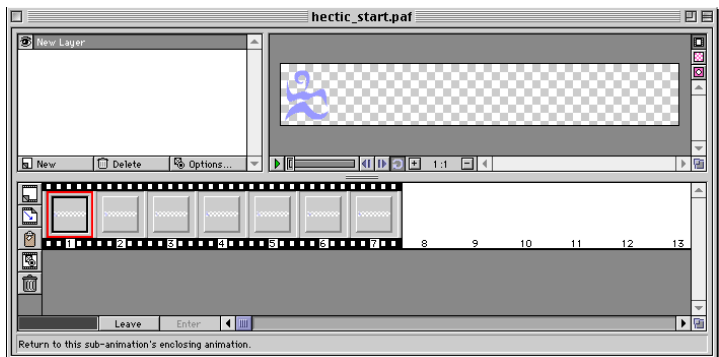

This imports a seven-layer Photoshop (.psd) document into PhotoAnimator. With the settings you specified in the Import Options dialog, each Photoshop layer was placed in the animation file as a separate single-frame cell. We now have a Nested Sub-Animation that contains seven cells.

### Tip

To instantly hide all layers but one, press the **Option [ALT]** key while clicking on the eye icon of the layer you wish to keep visible. Option-clicking (Macintosh) or ALT-clicking (Windows) again will unhide all the layers.

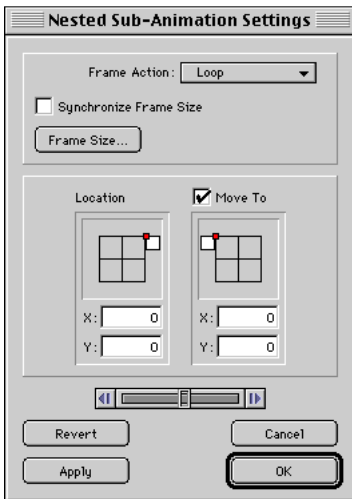

Leave

Click “Leave” to return to the regular animation work area.

- Hide all the of the layers in the animation except for the Run Left (Nested) layer.



Now preview the animation.

The little character runs in place on the left side of the screen.

- To help you see the little character more easily, unhide the Background layer.



Preview the animation again.

Now it’s time to experience the fundamental advantage of a nested animation. You will make this little guy run across the entire animation instead of just in place.

#### 4. Make the Nested Sub-Animation move across the frame.

- Double-click on any frame in the cell on the Run Left (Nested) layer in the Filmstrip Pane.

This opens the Nested Sub-Animation Settings dialog box.

- In the Nested Sub-Animations Settings, click the “Move To” check box (it should now display a checkmark).
- In the “Location” field, drag the small white rectangle of the Image Proxy to the top-right corner of the grid. Position it so that it is off-screen on the top-most right-hand edge of the grid. (See screenshot at left.)
- In the “Move To” field, drag the small white rectangle of the Image Proxy to the top-left corner of the grid. Position it so that it is off-screen on the top-most left-hand edge of the grid. (See screenshot at left.)
- Click “OK” to apply the settings and close the dialog.



Once again, preview the animation.

Notice that the little character runs across the entire animation from left to right. PhotoAnimator has taken the stationary nested animation and moved it over the banner making it appear as if the running character is running from one place to the other!



**Turn on the other layers and preview the entire animation.**



You can non-destructively manipulate the nested animations as much as you want before you export the animation. Photo-Animator also allows you to apply effects to nested animations and nested animations can have multiple layers just like a normal animation.

You will discover that you can create awesome animation effects very easily using Nested Sub-Animations—animations that would take you hours to create with a traditional gif animation tool.

In the final tutorial (Tutorial 5) you will learn about Photo-Animator's powerful Export options.

# Tutorial 5: Exporting

---

PhotoAnimator has three export options. You can export as a GIF animation, as a Photoshop file, and as a PhotoAnimator file or template. You will look at all three options in this tutorial, but the lion's share of this tutorial will deal with exporting a PhotoAnimator file to GIF animation.

## Exporting to a GIF Animation—The Banner Ad Animation

When you export to Animated GIF from PhotoAnimator you are converting the animation from millions of colors (24-bit) to anywhere from 256 to 4 colors (8, 7, 6, 5, 4, 3 and/or 2-bit). Also, all of the layers are merged down to a single layer for each frame.

In this first example, you will open a sample banner ad and export it as a GIF animation. Web banner ads need to download quickly over the Internet, so the the objective is to get this banner ad down to the smallest file size possible without sacrificing the visual quality of the images in the animation.

### 1. Specify Export Format



- **Open the “EPA\_ad.paf” file located in the Tutorial 5 folder on the Extensis CD.**

Don't worry about previewing the animation, you will do that several times within the Export dialog box.

- **Select File > Export... from the menubar.**
- **From the Format pop-up, select “Animated GIF.”**

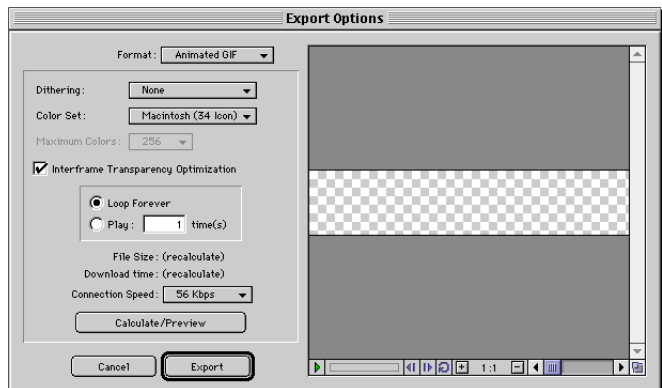

## 2. Specify Dithering

- **Examine the Dithering pop-up menu and notice that there are three options: None, Diffusion, and Pattern.**

In general the “None” option provides the best GIF compression. The Diffusion option can be a better choice for visual quality in some cases. Pattern is an another alternative to instead of the Diffusion option.

- **For this example, select Dithering: None.**

## 3. Specify Color

- **Examine the Color Set pop-up menu.**

PhotoAnimator provides a wide range of palettes, including the Netscape palette (also known as the “Web palette”) as well as several Macintosh and Windows palettes. Most animators will opt for the Adaptive palette which creates an adaptive palette from the available colors in the layered 24-bit version of the animation. In most cases the adaptive palette will result in an animation that looks as close to the 24-bit original version as possible.

- **Select Color Set: Adaptive**

*Note: As you create content that you will animate in PhotoAnimator, we recommend choosing colors from the Netscape palette whenever possible. This will help maintain the visual integrity of the animation when it is viewed on 8-bit systems. Just be aware that, though the Netscape palette is often recommended, selecting this palette on export often results in unnecessary visual quality loss in the animation when the animation is not predominantly composed of colors from the Netscape palette, such as photographic images.*

## 4. Specify Maximum Colors

- **Examine the Maximum Colors pop-up menu. Note that you have the option of choosing from 256, 128, 64, 32, 16, 8 and 4 colors.**

PhotoAnimator will generate a palette for the animation that contains no more colors than the number you have selected. For example, if you choose 64, PhotoAnimator will create a palette for the animation that contains 64 colors. PhotoAnimator will do this while attempting to keep as many colors from the original 24-bit color version as possible.

However, PhotoAnimator always performs certain optimiza-

tions for you automatically. For instance, if you choose 64 colors and the image you are exporting actually contains fewer than 64 colors, PhotoAnimator automatically removes unused colors from the color palette to ensure that you will end up with the smallest possible file size.

Note that the Maximum Colors pop-up menu is only available when Adaptive palette is the selected Color Set pop-up menu.

- **For now, select Maximum Colors: 256**

## 5. Specify Optimization

Below the Maximum Colors pop-up menu is the Interframe Transparency Optimization check box.

If you check this option, PhotoAnimator will optimize the animation by building transparency into the animation's frame whenever possible. Web browsers display GIF animations by displaying one frame over another. If parts of one frame contain the same imagery as in the previous frame, you can reduce the file size of the animation by making these redundant portions of the frame transparent.

To demonstrate how valuable this can be, leave this option off for now.

- **For now, de-select (uncheck) Interframe Transparency Optimization.**

*Note: Depending on the content of your animations, sometimes this option can actually make the file size larger. However, PhotoAnimator can calculate the file size of your animation based on the Export options you specify. You will see that it is quite easy to compare file sizes as you make different choices to end up with the smallest file size.*

## 6. Examine Loop options

With these options you can specify whether you want the animation to loop indefinitely or not.

- **Select Loop: Forever.**

The remaining features in the Animated GIF Export Options dialog box allow you to preview the results of the options you have selected before you export.

This is a very valuable aspect of PhotoAnimator. It means that you can experiment with various options and preview them before you actually export to GIF.

Before you move on, notice that there are two lines that read “File Size” and “Download Time.” These two lines both have the word “recalculate” next to them in parenthesis. This will be explained in a moment.

## 7. Test your animation with the options you specified

- **Click the Calculate/Preview button and watch carefully.**

After a few seconds, the Calculate/Preview button will become grayed out. Notice that there are now values displayed by the “File Size” and “Download time”.

- **Verify that the display indicates the following values:**

**File Size = 24,928 bytes**

**Download time = 12 seconds.**

The “File Size” indicator tells you how large the file will be, in bytes, if you were to export the animation with the current settings. The currently displayed values tell you that if you were to export this banner ad with dithering set to none, using an adaptive palette with 256 colors, and no interframe transparency optimization, the animation would have a file size of 24,928 bytes, which is about 24.9 Kilobytes.

The “Download time” indicator is related to the Connection Speed pop-up menu, which displays 28.8 Kbps (Kilobytes per second) by default. Our “Download time” readout indicates that it will take approximately 12 seconds to download this animation with a file size of 24.9K. If you select a different download speed from the Connection Speed pop-up menu, this Download time will change to reflect how long it would take to download the animation at its current file size on the selected connection speed.

The Download time and Connection Speed options in the Animated GIF Export Options dialog box allow you to generate animations that are optimal for your target connection rate. In other words, if you think that the majority of your site’s visitors will be connected to the Internet with 14.4Kbps modems, you can use these features to help make sure that your animations will work within any parameters that you have set for the site.

*Note: The Preview will play back the animation at the Frame Rate speed you choose from the Animation > Frame Rate... menu before you enter the Export Options Dialog box. In other words, the playback speed of an animation has nothing to do with how long an animation takes to down-*



load to the viewer's page. It takes a certain amount of time for an animation to download before it will begin its seamless playback in the viewer's browser, and that speed is what the Download Time calculation is showing you.

Twelve seconds is a long time to have to wait for this banner ad, especially since banner ads are usually not the only thing on a Web page. You will need to make this animation much smaller. Fortunately, with PhotoAnimator this is easy to do.

## 8. Minimize download time

- **Select Interframe Transparency Optimization by clicking the box (checkmark in it).**

Notice that the Calculate/Preview button becomes active and the “File Size” and Download time” options now display “(recalculate).” This indicates that some parameter used in the previous calculation has been changed and the values must be recalculated.

- **Click the Calculate/Preview button.**

The File Size indicator now shows that the file size has dropped to 21,643 bytes (21.6K) and the Download time is now approximately 11 seconds. You have chopped over 3K off the animation's file size and cut the download time by 1 second. Not bad, but you're just getting warmed up!

- **Select Maximum Colors: 16, then click the Calculate/Preview button again.**

Now File Size indicates that the animation would only be 12,264 bytes and the Download time would take a mere 6 seconds to travel over the Internet. In other words, by reducing the color palette to 16 colors, and turning Interframe Transparency Optimization on, you can cut the file size (and thereby the download time) of the animation in half.

It is nice that you've been able to make the animation's file size so small, but you don't want to present a poor quality animation. You've just thrown out 240 colors— will the animation still be worth looking at?

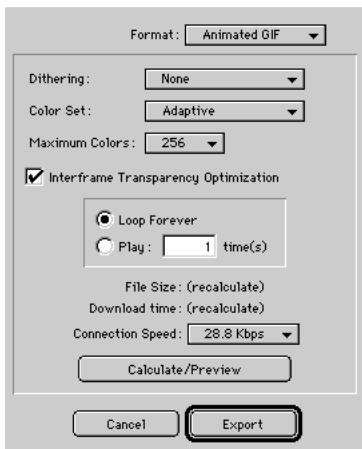

## 9. Preview the animation to verify its visual quality, then Export the animation



Press the Loop button in the animation Player in the Export Options dialog, then Preview the animation.



The Preview window in the Export Options dialog will show you how the animation will look at the calculated settings. Note that the Preview is not available until a download time has been calculated.

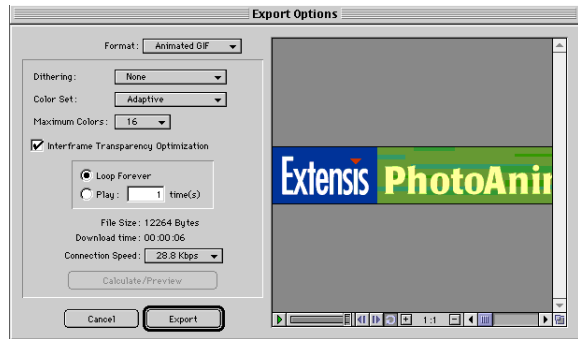

If you zoom in and study parts of the animation you'll see that the animation looks very similar to the original 24-bit version. But let's confirm this.

- **Select Maximum Colors: 256 while the animation Preview is still running.**

Notice that you do not have to click on the Calculate/Preview button again. PhotoAnimator remembers the settings of the previous calculations you chose so that you can switch back and forth between 256 and 16 colors while the preview is playing to compare the differences.

Since you have verified that our settings are satisfactory (16 color adaptive palette with no dithering and Interframe Transparency Optimization turned on), you can now to export the animation.

Important: This part of the tutorial is extremely complicated, so pay very close attention. Even seasoned professionals get lost when trying to perform this step. Now then...

- **Click the Export button.**

In all seriousness, that's all there is to it. PhotoAnimator takes care of everything for you, automatically generating an optimized GIF animation from your 24-bit layered PhotoAnimator document.

To fully appreciate this, look carefully at the image below.

### Tip

You can set the rate of an animation with the Frame Rate command located in the Animation menu, or by pressing **Command+G** (Macintosh) or **Control+G** (Windows).



This image shows what the exported animation looks like frame-by-frame. The light and medium gray blocks represent the portions of the animation optimized with interframe transparency. In other words, the light and medium gray portions represent transparency.

Another important thing to notice is that the animation exported only 14 frames. If you look at the filmstrip layers in the “EPA\_ad.paf” file you will see that some layers are as many as 45 frames long. However, the majority of these frames are static duplicates. That is, 32 frames are each duplicates of one another. The duplicates are there so that the animation will pause on the last frame long enough for the viewer to read the text on the banner ad, before the animation loops back to the beginning and starts over again.

PhotoAnimator recognized the duplicate frames and compiled them all into one frame by lengthening the display time of that frame. While the first 13 frames of the animation each display for 7/100ths of a second, the last frame of the animation is displayed much longer: just over two seconds. Including those redundant frames in the animation would have added to the animation’s file size unnecessarily.

## **Tips for Keeping GIF Animation File Sizes Down**

While PhotoAnimator automates the process of optimizing an animation's file size, it can only do so much with what it has been given. It is very easy to create prohibitively large GIF animations with PhotoAnimator's powerful animation features. Consider these guidelines for keeping your animation files manageable.

### **1. Keep transitions to as few frames as possible.**

For instance, if you are moving a logo across a banner ad and you have set the motion to occur across 15 frames, could you achieve a believable effect by using only 10 or even 5 frames? If your file size is not as low as you want it to be, try resizing your cells to fewer frames, then compare the difference.

### **2. Use the Fade transition sparingly.**

In order to achieve it's effect, the Fade transition effect must add colors to your animation which will make it more difficult to export your animation at lower bit depths. A lot of the time, using one of the Wipe or Barn Door transitions will create a similar effect, but with a much smaller hit on file size.

### **3. Try to confine your animation to a small palette.**

Heavy use of colorful photographic or 3D images can make it difficult to export your animation at lower bit depths without sacrificing image quality.

### **4. Use the Dithering: None option whenever possible.**

The GIF format employs LZW compression, which works best with contiguous strings of same-color pixels. So the more dithering in an image, the more difficult it will be for the GIF format to compress the animation.

## **Exporting to Photoshop Format**

PhotoAnimator also allows you to export to a layered Photoshop file. The main benefit to this export option is that it allows you to export frames created with PhotoAnimator for editing back in Photoshop. Since PhotoAnimator also imports layered Photoshop files, you can export out a PhotoAnimator file out as a layered Photoshop file and then re-import the results back into PhotoAnimator. This makes PhotoAnimator an excellent animation companion to Adobe Photoshop.

And what is really cool about this Photoshop support is that PhotoAnimator understands all of Photoshop's transparency and layer information. (Example: If you create some text on a layer in Photoshop, and then create a 50% opaque drop shadow of the text on a separate layer, PhotoAnimator will bring in both layers and retain the transparency of the drop shadow. Woo-hoo!)

The Photoshop Export Options dialog box contains only two options, both of which control the Frame Order of the exported file. You can choose to have the frames ordered from Top to Bottom (frame 1 of your PhotoAnimator document will translate to the top layer in the layered Photoshop file, and so on) or you can elect to have the frames ordered from Bottom to Top (the last frame of your PhotoAnimator document will translate to the top layer in the layered Photoshop file, and so on).

Note that, unlike exporting to the GIF format, all redundant PhotoAnimator frames are exported as individual Photoshop layers. For example, our 45 frame example animation will export to a 45 layer Photoshop file.

### **Exporting to PhotoAnimator File or Template**

PhotoAnimator's final export option is to a PhotoAnimator file (PAF) or template (PAT). The advantage of exporting to a PhotoAnimator file is that you can then import the file back into PhotoAnimator as a Nested Sub-Animation.

Exporting to a PhotoAnimator Template allows you to construct a layered document in PhotoAnimator that you can use over and over again by simply swapping in different images. For example, you might make a template for banner ads so that you can simply swap in a different message or background and to generate any number of ads from the template.

# Tutorial 6: Creating a Texture for Buttons

This tutorial will show you how to use PhotoTexture to create a texture file to be used on buttons created in PhotoButton. The following tutorial (Tutorial 6) (*page 170*) will show you how to apply that texture to your buttons. For detailed information about the tools and features presented in this tutorial, see the PhotoTexture section of this User Guide (*page 11*).

## 1. Open Photoshop and create a new RGB document.

This is the file that you will use for your buttons. The Photoshop file we created had the following dimensions:

200 x 300 pixels, 72 dpi, RGB, Contents: White

## 2. Choose “PhotoTexture” from the Extensis menu.

PhotoTexture allows you specify what you will be using as a basis for the texture. For this exercise we will be creating a texture from scratch using a “blank” workspace.

In the New dialog box, enter:

Width: 100

Height: 100

## 3. Choose Contents: Blank, then Click “OK.”

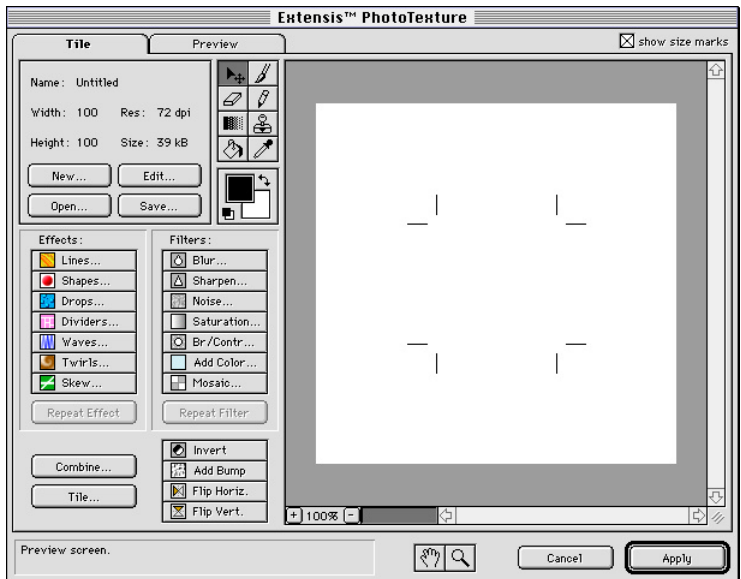
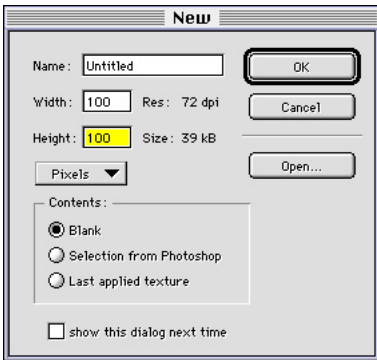

PhotoTexture opens with a blank tile in the Drawing Area.



4. Start the texture by creating a background color: Click the “Add Color...” button in the Filters list.



Click on the color well and choose a Dark Blue color from the color picker, then move the Opacity slider to 100%.



5. Add a droplet effect to the texture by clicking the “Drops...” button in the Effects list.

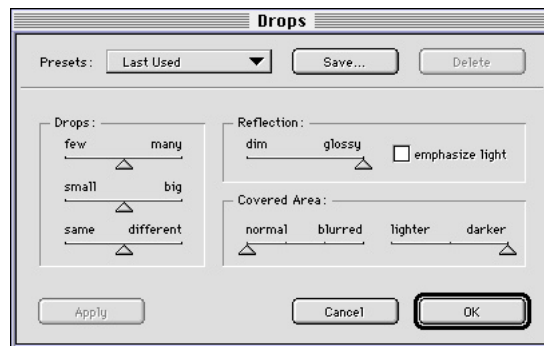
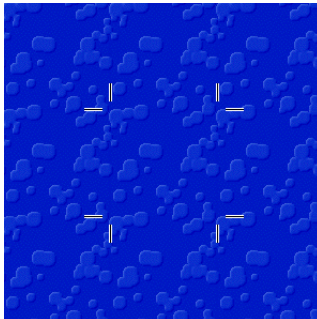

You can adjust the settings to match the settings we used, or choose your own. Click “Apply”—this allows you to see the results of your effect without closing the dialog. When you are happy with the results, click “OK.”



6. Reapply the Drops Filter by clicking the “Repeat Effect” button repeatedly until you are happy with the results. You can also press (Command-E) [Ctrl+E] to apply the last-used effect.

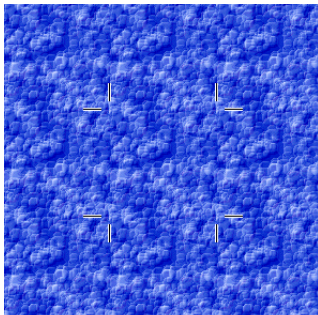

For this example, we repeated the Drops effect 10 times.





7. Add a swirl effect to the texture by clicking the “Twirls...” button in the Effects list.

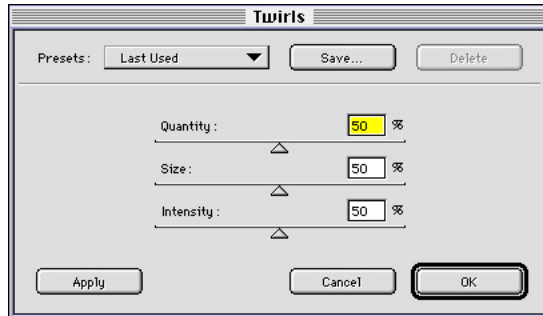
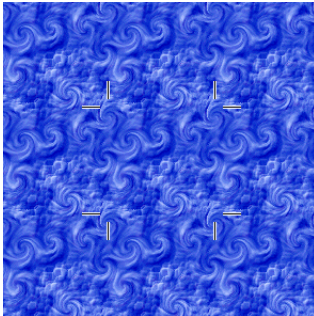

You can use whatever settings you prefer; we chose the default settings. Click “OK” to apply the settings to the texture and close the dialog.



8. Reapply the Twirls effect by click the “Repeat Effect” button repeatedly until you are happy with the results. You can also press Command-E [Ctrl+E] to apply the last-used effect.

For this example, we repeated the Twirls effect 4 times.

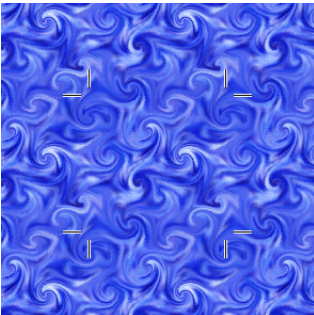

9. Save the texture as a JPEG file by clicking the “Save...” button in PhotoTexture. Name the file “blue twirls.jpg” and save it to your desktop.



This is the texture file that you will import into PhotoButton and apply to your buttons.

10. Click “OK” to accept the JPEG setting of 75.

11. When you return to the main PhotoTexture dialog box, close PhotoTexture by clicking “Cancel.”

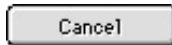

Since you have already saved the texture as an image file, you do not need to Apply it to your Photoshop document.

You can now apply the texture you created to your buttons in PhotoButton.

# Tutorial 7: Creating Buttons and Adding Textures

## Important

If you did not create a blank document as shown in step 1 on page 167, create one now: 200 x 300 pixels, 72 dpi, RGB, Contents: White

This tutorial will show you how to create buttons and apply the texture that you created in Tutorial 5 (page 167). For detailed information about the tools and features presented in this tutorial, see the PhotoButton section of this User Guide (page 49).

1. In Photoshop, open PhotoButton by selecting it from the Extensis menu (Extensis > PhotoButton > PhotoButton), then click the “Reset” button.

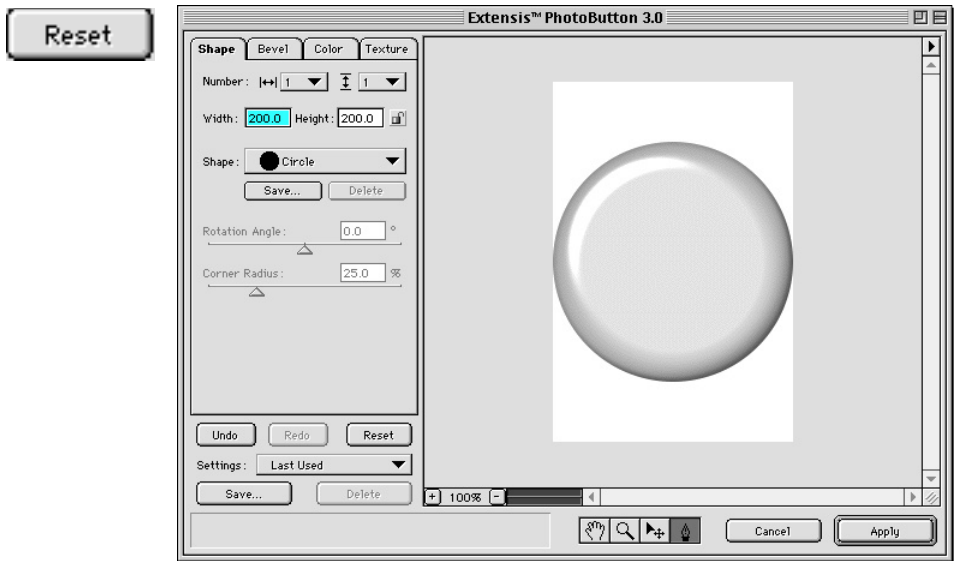

This resets the button parameters to their default values.

2. Start creating your buttons with the Shape tab. Verify that the current button shape is a Circle.
3. Choose “2” from the Vertical Number pop-up menu and “1” from the Horizontal Number pop-up menu, then enter a Width and Height of “140.”

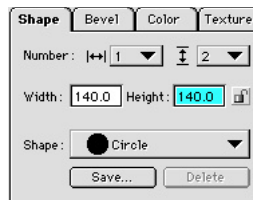
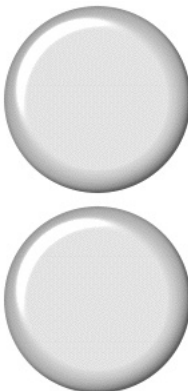

This creates two Circle buttons that will be applied to the Photoshop document we created in step 1 on page 167.

4. Click the Bevel tab to select it. Use the following settings:

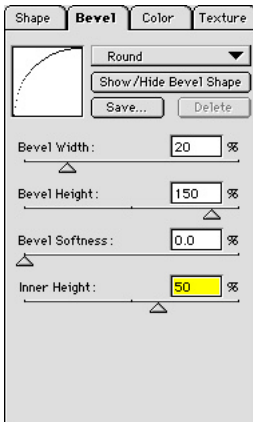

Bevel Preset: Round  
 Bevel Width: 20  
 Bevel Height: 150  
 Bevel Softness: 0  
 Inner Height: 50

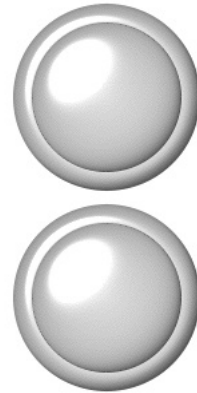

5. Click the Color tab to select it, then add color to the buttons by holding down the Option-Shift [Alt+Shift] keys while you select a color from the Paint Color pop-up menu. This fills all the parts of all buttons with the color you chose.

You could instead use the Paint Bucket to color the buttons by choosing a color from the pop-up and then clicking each part of the button(s) you wish to color with the Paint Bucket tool.

**Within the Color tab, click on the Inner tab: Choose Rubber from the Materials pop-up menu.**

**Within the Color tab, click on the Bevel tab: Choose Rubber from the Materials pop-up menu.**

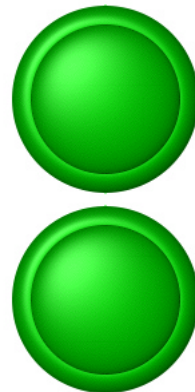
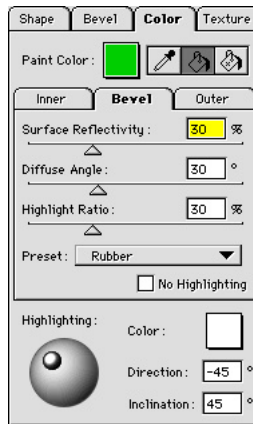
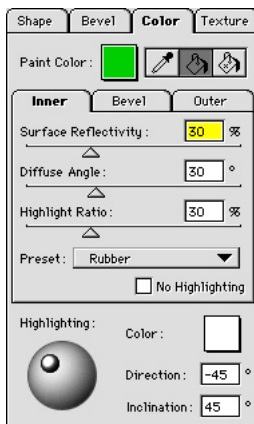

Import...

- 6. Click the Texture tab to select it, then click the “Import...” button. Locate the “blue twirls.jpg” file you saved on the Desktop earlier.

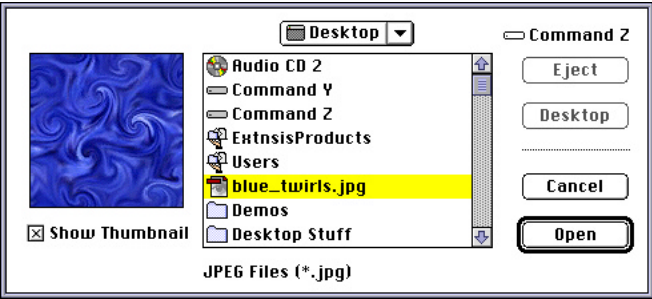

The texture is now ready to be applied to the buttons.

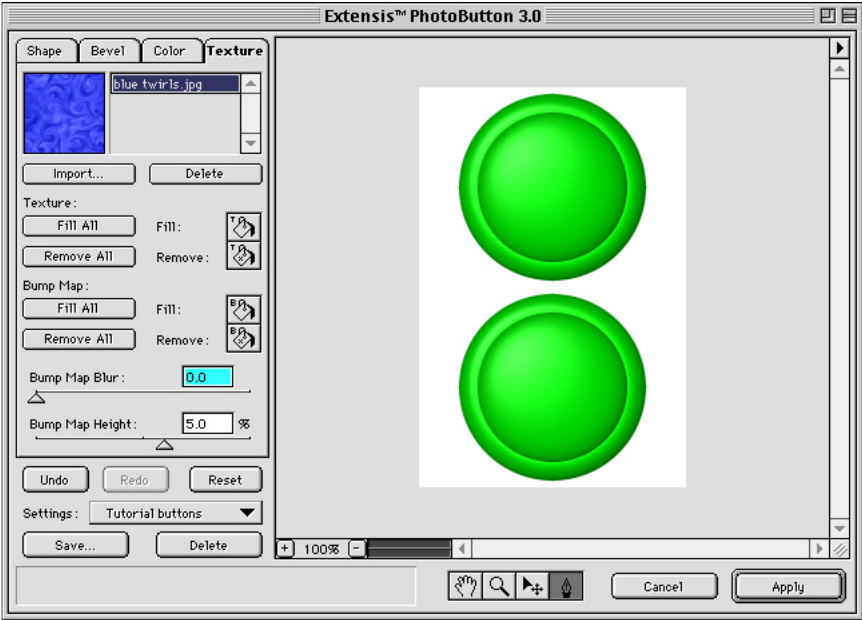

Alternately, you can drag and drop any JPEG texture file(s) directly into PhotoButton from the Desktop. If you drag and drop textures into PhotoButton, be aware that you won't see the them until you select the Texture tab.

7. Apply a texture to the top button by selecting the **Texture Paint Bucket tool**, then clicking on the inner surface and the outer bevel of the top button to fill that button with the selected texture.

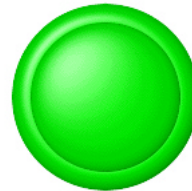

8. Apply a bump map to the bottom button by select the **Bump Map Paint Bucket tool**, then click on the inner surface and the outer bevel of the bottom button to apply a bump map to their surfaces.



You can adjust the settings of the bump map. These are the settings we used: Bump Map Blur: 1.0, Bump Map Height: 10

You now have a button with a texture applied, and another with a bump map applied. Try applying the bump map to the button with the texture to create a different effect.

# Appendix A: Keyboard Shortcuts

---

## PhotoAnimator

Function Performed	Macintosh	Windows
Cut	Command-X	Ctrl+X
Copy	Command-C	Ctrl+C
Paste	Command-V	Ctrl+V
Select All	Command-A	Ctrl+A
Undo	Command-Z	Ctrl+Z
Redo	Command-Y	Ctrl+Y
Import	Command-I	Ctrl+I
Export	Command-E	Ctrl+E
Frame Size	Command-F	Ctrl+F
Frame Rate	Command-G	Ctrl+G
New Layer	Command-L	Ctrl+L
New Cell	Command-K	Ctrl+K
Delete Cell	Delete or Del	Backspace or Delete
Duplicate Cell	Option+Drag cell	Alt+Drag cell
Extend Cell	Option-Click on blank frame	Alt+Click on blank frame
New Cell	Shift-Click on blank frame	Shift+Click on blank frame
Effect Settings (for currently applied effect)	Command-T	Ctrl+T
Play/Stop Animation	Spacebar	Spacebar
Preview Zoom In	Command-“+”	Ctrl+“+”
Preview Zoom Out	Command-“-”	Ctrl+“-”
Hide all layers except this one	Option-Click eye icon	Alt+Click eye icon
Show all layers including this one	Option-Click eye icon	Alt+Click eye icon
Select (relative to currently selected)		
First Frame in layer	Home	Home
Last Frame in layer	End	End
Frame Right	→	→
Frame Left	←	←
Cell Right	Shift+→	Shift+→
Cell Left	Shift+←	Shift+←
Layer Up	↑	↑
Layer Down	↓	↓
New Animation File	Command-N	Ctrl+N
Open Animation File	Command-O	Ctrl+O
Save Animation File	Command-S	Ctrl+S
Close Animation File	Command-W	Ctrl+F4 or Ctrl+W
Quit PhotoAnimator	Command-Q	Alt+F4 or Ctrl+Q

## PhotoEffects (PhotoButton, PhotoGroove, PhotoCastShadow, PhotoBevel/Emboss/Glow)

Function Performed	Macintosh	Windows
Cut	Command-X	Ctrl+X
Copy	Command-C	Ctrl+C
Paste	Command-V	Ctrl+V
Select All	Command-A	Ctrl+A
Undo	Command-Z	Ctrl+Z
Redo	Command-Y	Ctrl+Y
Apply Effect (and close dialog box)	Return or Enter	Return or Enter
Cancel (and close dialog box)	Command-. or Escape	Alt+F4 or Esc
Pan and Zoom		
Zoom In	Command-“+”	Ctrl+Keypad “+”
Zoom Out	Command-“-”	Ctrl+Keypad “-”
	Option+Zoom tool	Alt+Zoom tool
Access Hand tool from any tool	Spacebar	—
Access Magnifier “+” from Hand tool	Command	—
Access Magnifier “-” from Hand tool	Option	—
Access Magnifier “+” from other tool	Spacebar+Command	—
Access Magnifier “-” from other tool	Spacebar+Option	—
Fit on Preview	Command-0	Ctrl+0
Actual Pixels	Command-Option+0	Ctrl+Alt+0
View Composite Layer	Command-L	Ctrl+L
Parameter Boxes		
Move forward one character	→	→
Move backward one character	←	←
Move forward one box	Tab	Tab
Move backward one box	Shift-Tab	Shift+Tab
<b>PhotoCastShadow only</b>		
Toggle Show/Hide Outline	Command-H	—
Reset Shape Options Only	Option+Reset	Alt+Reset
Constrain to Side movement	Adjust tool+Command-Drag	Adjust tool+Ctrl+Drag
Constrain Horizontally/Vertically	Adjust tool+Shift-Drag	Adjust tool+Shift+Drag
Resize from Center	Adjust tool+Option+Drag	Adjust tool+Alt+Drag
Resize proportionally from Corner	Adjust tool+Command-Drag	Adjust tool+Ctrl+Drag
<b>PhotoButton only</b> (*affects all buttons)		
Fill Inner*	Command-I	Ctrl+I
Fill Inner* with Pop-up Color	Shift-Select color	Shift+Select color
Fill Inner* with Extracted Color	Shift-Eyedropper-Click	Shift+Eyedropper+Click
Fill Bevel*	Command-B	Ctrl+B
Fill Bevel* with Pop-up Color	Option+Select color	Alt+Select color
Fill Bevel* with Extracted Color	Option+Eyedropper-Click	Alt+Eyedropper+Click
Fill Outer*	Command-U	Ctrl+U
Fill Outer* with Pop-up Color	Command-Select Color	—
Fill Outer* with Extracted Color	Command-Eyedropper-Click	—
Fill Part* with Paint Color	Option+Paint Bucket-Click	Ctrl+Paint Bucket+Click
Show/Hide Grid	Command-"	Ctrl+"
Show/Hide Outline	Command-H	Ctrl+H
Resize from Center	Pen tool+Option+Drag	Pen tool+Ctrl+Drag
Constrain Reshape to Horizontal/Vert	Pen tool+Shift-Drag	Pen tool+Shift+Drag

## Appendix B: Troubleshooting

---

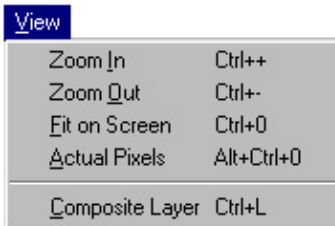

**1. Nothing changes in my image Preview when I make changes using the effect tools.**

Each PhotoEffects plug-in allows you to disable real-time viewing. If you don't see any changes in your image as you apply different effect parameters, check the "Options" menu in the menubar to be sure that "Real Time Preview" is selected.

**2. The background (or other layer) doesn't appear in the Effect's Preview window.**

If you expected to see all the layers in your picture and didn't, check the "View" menu in the menubar to be sure "View Composite Layer" has been selected. Also verify that the layers you wish to view have been selected for viewing in the Photoshop layers palette.

See also "Additional Information" on page 46.

**3. I'm working with a Transparent layer (PhotoButton) and when I click "Reset" there appears to be no button in the Preview window.**

The default fill color for PhotoButton is "Transparent." When working on a normal (not Transparent) layer, for example the background layer, this feature allows the background image to "show through" a semi-opaque button. This feature allows you to create stunning button effects with textures, gradients, etc. Adding this automatic Transparent fill to an already Transparent layer results in an apparently "invisible" button. However, the button is there!

**To see the transparent button:**

Use the Color controls to fill the button so you can see it. or use the Reshape tool.

— or —

Select the Reshape tool and move it around the Preview window—the button frame will appear and show you the button.

*For more information on Transparent options, refer to the PhotoButton section of this User Guide (page 67).*



**5. When I select a different blend mode in PhotoCastShadow or PhotoGlow, nothing seems to happen.**

The blend mode in PhotoCastShadow and PhotoGlow only blends the effect with the pixels in the target layer. If there are no pixels with color in the target layer, you will see no “blending” in the Preview.

# Index

---

3-D bevels, creating 71-76, 84  
3-D buttons, creating 49-70  
3-D shadow effects, creating 77-83

## A

Actions Palette Awareness 48  
Actions Palette Scripting 46  
Adding  
    button icons, Macintosh 94-97  
    button icons, Windows 101-102  
    buttons to a toolbar 92  
Additional Information about effects 46  
Adjustment tool  
    for buttons 49, 58-59  
    for shadows 78, 82  
Anchor button 55-56  
Apply command  
    Effects 36, 38  
    keyboard shortcut 175

## B

Background processing 42  
Bevels *See also* “PhotoGroove,” “PhotoButton,”  
    “PhotoBevel”  
    and buttons 51, 62-66  
Button  
    adding bump map to 70  
    coloring 68-69  
    texturizing 70  
    creating 71-76, 84  
Blend Mode  
    and shadows 78  
    unexpected results with 177  
Bump Map, adding to buttons 70  
Buttons *See also* “buttons, toolbar”  
    *See also* “PhotoBars”  
    *See also* “PhotoButton”  
    Anchor 55-56  
    bevels 51, 62-66  
    Color 49, 52, 67-69  
    color modifier keys 68, 175  
    inner part, discussed 56  
    matrix 54  
    number, specifying 54  
    outer area, discussed 56  
    parts defined 56  
    tutorial 167-173  
buttons, toolbar *See also* “PhotoBars”  
    adding 92  
    adding space between 91

    creating new  
        Macintosh 94-97  
        Windows 101-102  
    finding in library 92-93  
    for Finder Items, Macintosh 97  
    for Keystrokes  
        Macintosh 95  
        Windows 101-102  
    for Menu Items  
        Macintosh 96  
        Windows 101-102  
    for Plug-ins and Filters  
        Macintosh 92  
        Windows 92  
    icons, creating your own  
        Macintosh 100  
        Windows 102  
    rearranging 91  
    removing 90  
    repositioning 91

## C

Cancel command 38,  
Cast Shadow Preset 36, 83  
Cast shadows, creating 77-83  
Categories of toolbars, accessing 92  
Color Modes 48  
Color Palette  
    for Buttons 45, 49, 52, 67-69  
    for Effects 45  
    for Textures 10, 17, 21, 26  
Color tab in PhotoButton 49, 52, 67-69  
Color tools  
    for PhotoButton 49, 52, 67-69  
    for PhotoEffects *See* “Color Palette”  
Composite Layers  
    for Effects 40  
Composite preview *See* “Composite Layers”  
Control knob  
    for adjusting button highlight color 69  
Corner Radius, of button 50  
Create Glow Only 86  
    discussed 47  
Create Shadow Only 83  
    discussed 47  
Creating New Buttons  
    for Macintosh toolbars 94-97  
    for Windows toolbars 101-102  
Customize toolbars  
    dialog box 92  
Cutout, Shadow Preset 83

- D**
- Diffuse Angle 52, 69
  - Distort
    - button 59, 60-61
    - shadow 77, 81-82
  - Drop Shadow Preset 83
  - Drop shadows, creating 83
- E**
- Edge Tolerance, of Bevel Editor
    - Bevel Shape 72, 73-75
    - for Buttons 51, 62-66
  - Effects *See* specific effect (e.g. “PhotoGlow”)
  - Effects, common elements 38-48
  - Effect Settings
    - deleting 37
    - Presets 37
    - saving 36
    - using 37
  - embedded toolbar *See* “toolbars, embedded”
  - Emboss effect 85
  - Extensis, contacting 2, 6
  - Eyedropper tool
    - interactive previewing with 45
    - using, common effects 45
    - using, PhotoButton 68
- F**
- Files, adding to toolbar (Macintosh) 97
  - Fill All buttons
    - for Button Texture 53, 70
    - for Button Bump Map 53, 70
  - Fit on Preview command 40
  - floating palette *See* “toolbars, floating”
  - floating toolbar *See* “toolbars, floating”
- G**
- Getting Started
    - PhotoAnimator 105
    - PhotoBars 88
    - PhotoButton 54
    - PhotoCastShadow 79
    - PhotoEffects 35
  - Glow effect 86
  - Glow Diffusion 86
- H**
- Handles
    - for Button resizing 54-55, 57
    - for Shadow resizing 79, 82
  - Help Box 10, 38, 49, 71, 77, 84, 85, 86, 105
  - Highlight
    - of button 49, 52, 69
    - of bevel 71, 76
  - Highlight Ratio, button 52, 69
  - Hot Help 88 *See also* “Help Box”
- I**
- Icon Button Editor (Mac) 94-96, (Win) 101
  - icons *See* “buttons, toolbar icons”
  - Image Area of button matrix, defined 54
  - Image navigator 44
  - Inclination, of light source 69
  - Inner button part *See also* “Buttons”  
*See also* “PhotoButton”
    - adding bump map 70
    - coloring 68-69
    - discussed 56
    - texturizing 70
  - Inner Height, of button 64
  - Installation 6
  - Interactive wireframe
    - for Buttons 60-61 *See also* “Shape Outline”
    - for Shadows 77, 79
  - Invert
    - effect discussed 83
    - Selection command 78, 83
- K**
- Keyboard commands, creating buttons for
    - Macintosh 95-96
    - Windows 101-102
  - Keyboard shortcuts, listed
    - PhotoAnimator 174
    - PhotoEffects 175
- L**
- Last Used Preset discussed 36, 37
  - Layers
    - viewing, in Effects 46
    - unexpected results with 46, 176
  - Light Direction
    - Field and Indicator, of Button 49, 69
    - of Highlight *See* “Highlight”
  - Lock button size 57

- M**
- Matrix of buttons, defined 54
  - Measurements, in PhotoTexture, specifying 13
  - Modes, color 48
  - Moving
    - Buttons 49, 58-59
    - Shadows 79, 81
  - Multiple layers *See* “View Composite Layers”
  - Multiple undos 39
- N**
- Navigating windows 44
  - Navigator pop-up 44
    - discussed 44
    - using 44
  - Navigator, Preview 44
  - Neon effect 86
    - Preset for Buttons, applying 37
  - No Highlighting command, of Button 52, 69
  - None, color choice, of Button 67
  - Number of buttons, specifying 54
- O**
- Outer button area *See also* “Buttons”  
*See also* “PhotoButton”
    - coloring 68-69
    - discussed 56
- P**
- Paint Color, of buttons 49, 52, 67-69
  - Paint Bucket, using, to color buttons 68
  - Panning
    - how to 44
    - keyboard shortcuts 175
  - Perspective Blur
  - PhotoAnimator 103-119
    - about 7, 103
    - effects
      - Basic 113
      - creating, how to 110
      - Image 114
      - Mask 115
      - Transition 115, 116
    - Exporting 118
    - Filmstrip pane 107
    - Getting Started with 104
    - Importing 117
    - Layers pane 106
    - Preferences 119
    - Preview pane, of animation 106
    - Preview window, of PhotoAnimator 105
    - Proxies 112
    - Sample files, where located 103
    - System Requirements 103
    - settings
      - of animation 109
      - of effects 110-116
      - repeat last 110
    - terms defined 108
    - Tutorials 120-166
  - PhotoBars 87-102 *See also* “buttons, toolbar”
    - about 9, 33, 87
    - adding buttons to toolbars 92
    - adding space between buttons 91
    - creating new toolbars 91
    - customizing toolbars 92
    - Getting Started with 88
    - icons
      - creating (Macintosh) 100
      - creating (Windows) 102
    - removing buttons from toolbars 90
    - showing/hiding toolbars 88-89
    - SmartBar (Macintosh) 98
    - toolbars
      - creating new buttons (Mac) 94-97
      - creating new buttons (Win) 101-102
      - customizing 90-93
      - floating 89-90
      - embedded 89-90
  - PhotoBevel *See also* “PhotoGroove”
    - about 8, 33, 84
    - creating effects 84
    - Navigator pop-up, accessing 44
    - Preview window 84
    - tools, common 38, 43-45
    - tools, specific 84
  - PhotoButton *See also* “Buttons”
    - about 8, 33-34, 49
    - anchor button, explained 55-56
    - Applying 36, 38
    - bump map, adding 70
    - button, parts of 56
      - defined 56
      - coloring 68-69
      - texture, adding to 70
    - Adjust tool 49, 58-59
    - Bevel tab 51, 62-66
    - Color tab 49, 52, 67-69
    - custom shapes, creating 60-62
    - Getting Started with 54-59
    - Grid
      - enabling 62
      - size, changing 62
    - image area, explained 54

- lock button size 57
  - moving buttons in the image area 49, 58-59
  - matrix of buttons, defined 54
  - Navigator pop-up, accessing 44
  - number of, setting 54
  - Pen tool 49, 59
  - positioning 49, 58-59
  - Preview window 49
  - Shape tab 50, 60-61
  - shape
    - controls identified 49, 50, 58-59
    - changing 50, 58-59, 60-66
    - custom, things to know 61
    - grid 62
    - new, saving 61
    - outline, enabling/disabling 62
    - selecting 55
  - size
    - of grid, changing 62
    - locking 57
    - manipulating 54-55, 57
    - specifying 54-55, 57
  - size of, setting 54-55, 57
  - Texture tab 53, 70
  - tools, common 38, 43-45
  - tools, specific 49, 58-59
  - unlock button size 57
- PhotoCastShadow 77-83 *See also* “Shadows”
- about 9, 33, 77
  - Applying 36, 38
  - blur, perspective 78
  - controls
    - color 78, 80
    - noise 78, 80
    - position 78, 81
    - shape 78, 82
  - frame explained 79
  - Create Shadow Only 78, 83
  - Getting Started with 79
  - Invert Selection 83
  - moving around in the image area 79, 81
  - multiple shadows, creating 80
  - Navigator pop-up, accessing 44
  - noise 78, 80
  - Perspective Blur 78
  - Presets 36, 83
  - Preview window 77
  - repositioning 79, 81
  - resizing 79, 82
  - Shape tab 78
  - shaping 82
  - Style tab 78
  - tools, common 38, 43-45
  - tools, specific 77-83
  - wireframe 79
- PhotoEffects Plug-ins
- See also* specific effects (e.g. “PhotoGlow”)
- about 8-9, 33
  - actions palette scripting, about 48
  - Additional Information 46-47
  - Background Processing 42
  - Color Modes 48
  - Color Tools 45
  - common elements listed 34
  - common elements explained 38-48
  - composite layers 40
  - Create Shadow/Glow Only 47
  - defined 33
  - effect Settings 36-37
  - Fit on Preview 40
  - modes, color 48
  - Navigator pop-up 44
  - panning, how to 44
  - Preview window, typical 38
  - Real Time Preview 41
  - redo, multiple 39
  - reset all effects 39
  - undo, multiple 39
  - undo and RAM 48
  - View Composite Layers 40
  - zooming, how to 43
- PhotoEmboss 85
- about 8, 33,
  - Applying 36, 38
  - creating effects 85
  - Navigator pop-up, accessing 44
  - Preview window 85
  - tools, common 38, 43-45
  - tools, specific 85
- PhotoGlow 86
- about 8, 33, 86
  - Applying 36, 38
  - Create Glow Only 86
  - creating effects 86
  - Navigator pop-up, accessing 44
  - Preview window 86
  - tools, common 38, 43-45
  - tools, specific 86
- PhotoGroove 71-76
- about 8, 33, 71
  - Applying 36, 38
  - Bevel Shape Editor 72, 73-75
  - creating effects 71-76
  - custom bevels, creating 75
  - highlighting 76

- Navigator pop-up, accessing 44
- Preview window 71
- Shape Controls 72, 73-75
- shape, saving 75
- Style Controls 76
- tools, common 38, 43-45
- tools, specific 71-76
- PhotoTexture 10-32
  - about 7, 10
  - base tile, about 11-12
  - base tile, resizing 32
  - combining with another 30
  - Creating Textures
    - from an existing file 16
    - from scratch 14
    - from last applied texture 16
    - from Photoshop selection 15
  - effects 19, 20, 21-24
  - Effects and Filters 19-26
  - filters 19, 20, 25-26
  - Getting Started 11
  - pattern repetitions, changing 31
  - Preview 27
  - Saving 29
  - Texture File Options 13
  - Toolbar 17-18
  - tools 17, 18
  - Zooming 28
- PhotoTools, overview 7-9
- Pixels
  - in PhotoButton 54-55, 57
  - in PhotoTexture, specifying 13
  - toolbar button icon size 100, 102
- Plug-ins
  - one-click access *See* “buttons, toolbars”
  - PhotoEffects *See* “PhotoEffects Plug-ins”
- Pop-up
  - See* “Color Palette,” “Navigator”
- Positioning
  - Buttons
  - Shadows
  - toolbars
  - toolbar buttons
- Presets
- Preview window *See specific effect*
- Progress bar
  - Background processing
  - Preview processing

## R

- Radiance
- RAM Memory and multiple undos
- Real-time Preview
- Redo
- Remove All buttons
  - for Button Texture 53, 70
  - for Button Bump Map 53, 70
- Reset command 39
- Reshape and Resize tools
  - for bevels 72-75, 84
  - for buttons 48, 50, 54-55, 57, 58-59
  - for shadows 78-82
- Rotation angle
  - of buttons 50
  - of shadow 78

## S

- Scroll
  - how to 44
  - keyboard shortcuts 175
- Settings
  - See* “Effect Settings”
  - See* “Style Settings, for text”
- Shadow Frame explained 79
- Shadows, creating 77-83
- Shape controls
  - for Bevels 72, 73-75, 84
  - for Buttons 49, 50, 58-59, 60-61
  - for Shadows 78, 81-82
- Shapes, of Buttons 50, 58-59, 60-61
- Shape Outline, of Button 62
- Shape tab
  - PhotoButton 50
  - PhotoCastShadow 78
- Size of Button, specifying 54-55, 57
- SmartBar, creating toolbars with 98
- Software Requirements 5, 103
- Spacing
  - of Buttons, discussed 54-56, 57
  - of toolbar buttons, how to 91
- Surface Property Controls, of button 52, 67-69
- Surface Property tabs 52
- Surface Reflectivity, of Button 52, 69
- System Requirements 5, 103

## T

Technical Support, contacting 6

Textures

adding to buttons 70

creating 10-32

toolbar buttons *See* “buttons, toolbar”

toolbars

accessing files and folders 9

buttons, adding 92

categories of, accessing 92

changing from embedded to floating 89

changing from floating to embedded 90

customizing 92

embedded 89-90

floating 89-90

Hot Help, for toolbars 88

new, creating 91

Showing/Hiding 88-89

ToolTips, for toolbars 88

ToolTips, for toolbars 88

Transparent

backgrounds in PhotoAnimator 119

color, described 67

layers discussed 46

Tutorials

PhotoAnimator 120-166

PhotoTexture 167-169

PhotoButton 170-173

## U

Undo

a command, how to 39, 175

multiple 39

Unexpected Results *see* “Troubleshooting”

Unlock, button size 57

## V

virtual memory, and RAM discussed 48

## W

Watch Me button 98-99

What is PhotoTools? 7-9

Window Navigator 44

## X, Y, Z

X Offset, of Shadow 78, 81

Y Offset, of Shadow 78, 81

Zoom

how to

PhotoEffects 43

PhotoTexture 28

keyboard shortcuts 175